

EN Installation manual for control panel for REX and VALOR automations.

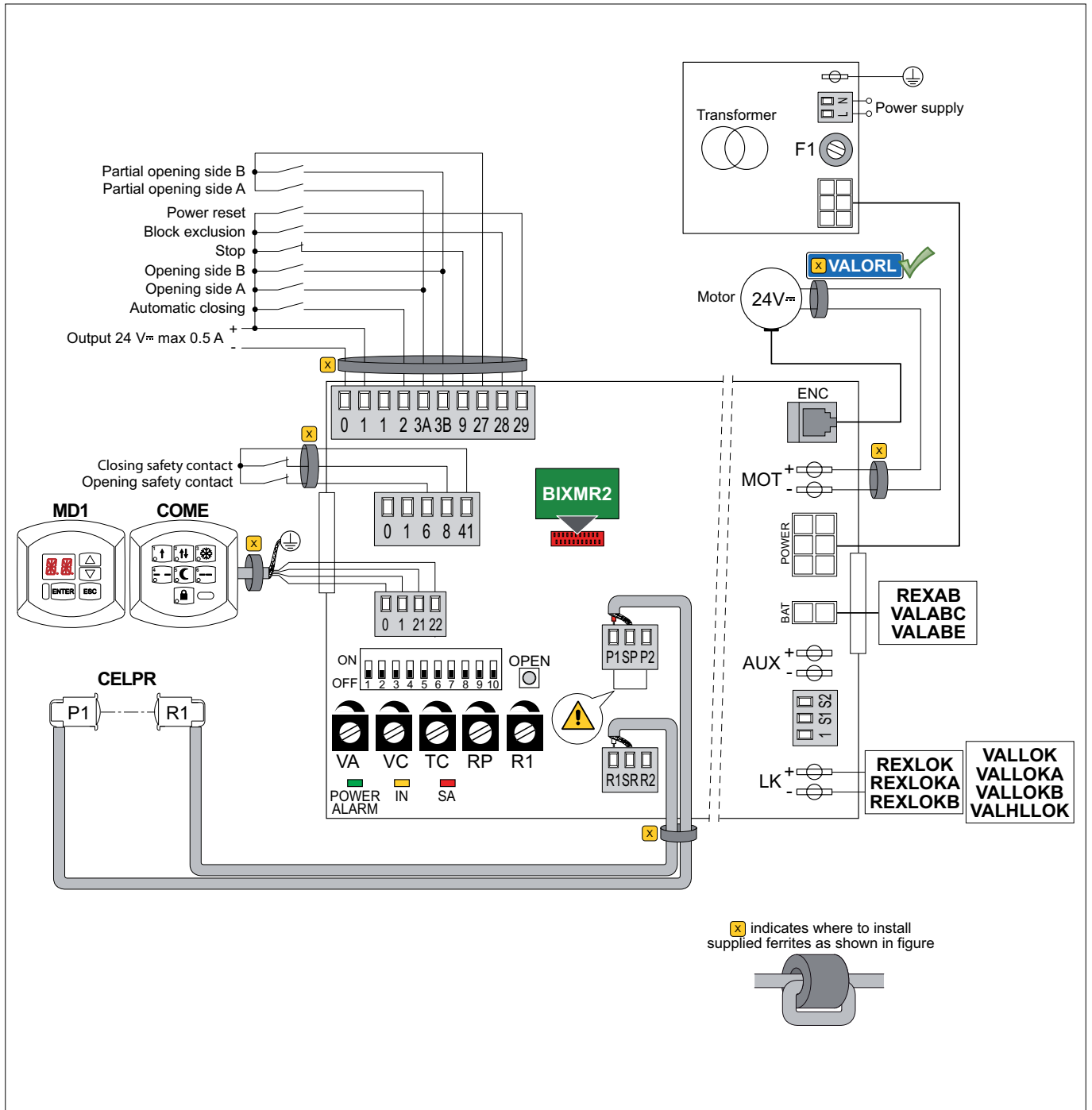

INDEX

Subject	Page
1. General safety precautions	3
1.1 Safety functions	3
2. EC declaration of conformity	4
3. Technical data	4
3.1 Applications	4
4. Commands	5
4.1 Non-testable safety devices	6
4.2 Testable safety devices	6
5. Outputs and accessories	7
5.1 Limit switch connection	8
5.2 CELPR photocell connection	8
6. Electromagnetic emissions	9
7. Adjustments	9
7.1 Trimmers enabling procedure	10
8. Start-up	11
9. Troubleshooting	12
10. Example application without function selector	14
11. Example application with COMH-COMK function selector	15
12. Example application with COME function selector	16

CAPTION



This symbol indicates instructions or notes regarding safety issues which require particular attention.



This symbol indicates informations which are useful for correct product function.



This symbol indicates instructions or notes intended for technical and expert personnel.



This symbol indicates operations not to be effected for not compromise the correct operation of the automation.



This symbol indicates options and parameters which are only available with the indicated item.



This symbol indicates options and parameters which are not available with the indicated item.

All right reserved

All data and specifications have been drawn up and checked with the greatest care. The manufacturer cannot however take any responsibility for eventual errors, omissions or incomplete data due to technical or illustrative purposes.

1. GENERAL SAFETY PRECAUTIONS



This installation manual is intended for qualified personnel only.

The installation, the power connections and the settings must be completed in conformity with Good Working Methods and with the regulations in force.

Before installing the product, carefully read the instructions. Bad installation could be hazardous. The packaging materials (plastic, polystyrene, etc.) should not be discarded in the environment or left within reach of children, as these are a potential source of hazard.

Before beginning the installation check that the product is in perfect condition.

Do not install the product in explosive areas and atmospheres: the presence of flammable gas or fumes represents a serious threat to safety.

The safety devices (photocells, sensitive edges, emergency stop, etc.) must be installed taking into account: the provisions and the directives in force, Good Working Methods, the installation area, the functional logic of the system and the forces developed by the automation.



Before making power connections, check that the rating corresponds to that of the mains supply. A multipolar disconnection switch with a contact opening gap of at least 3 mm must be included in the mains supply. Check that upstream of the electrical installation an adequate residual current circuit breaker and an overcurrent cut out are fitted.

When requested, connect the automation to an effective earthing system carried out as indicated by current safety regulations.

During installation, maintenance and repair operations, cut off the power supply before opening the cover to access the electrical parts.



To handle electronic parts, wear earthed antistatic conductive bracelets. The manufacturer of the motorisation declines all responsibility in the event of components which are not compatible with the safe and correct operation of the product.

For repairs or replacements of products only original spare parts must be used.

1.1 Safety functions

The EL20 control panel has the following safety functions:

- limitation of forces;
- prevention of contact.

The maximum response time of the safety functions is 1.5 s. The reaction time to a fault in a safety function is 1.5 s.

The safety functions comply with the standard and performance level indicated below:

EN ISO 13849-1:2006 Class 2 PL=c

2. EC DECLARATION OF CONFORMITY

Manufacturer: DITEC S.p.A.

Address: via Mons. Banfi, 3 21042 Caronno P.Ia (VA) - ITALY

declares that the control panel EL20 is in conformity with the provisions of the following EC directives:

EMC Directive 2004/108/EC;

Low Voltage Directive 2006/95/EC.

Caronno Pertusella, 30-06-2010

Silvano Angaroni
(Managing Director)



3. TECHNICAL DATA

	EL20	
	REX	VALOR
Power supply	230 V~ 50/60 Hz	230 V~ 50/60 Hz
F1 fuse	F1A	F1,6A
Motor output	24 V $\overline{=}$ 5 A	24 V $\overline{=}$ 10 A
Accessories power supply	24 V $\overline{=}$ 0.5 A	24 V $\overline{=}$ 0.5 A
Temperature	min -20 °C max +55 °C	min -20 °C max +55 °C



NOTE: the given operating and performance features can only be guaranteed with the use of DITEC accessories and safety devices.

3.1 Applications

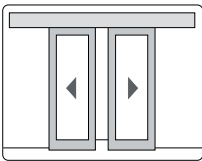



4. COMMANDS

Command		Function	Description
1 — 2	N.O.	AUTOMATIC CLOSING	A permanent contact enables automatic closing. COMH, COMK and COME function selectors automatically select automatic closing.
1 — 3A 1 — 3B	N.O.	SIDE A OPENING SIDE B OPENING	The closing of the contact activates the opening operation.
27 — 3A 27 — 3B	N.O. N.O.	PARTIAL OPENING SIDE A PARTIAL OPENING SIDE B	The closing of the contact activates the partial opening operation.
1 — 9	N.C.	STOP	The opening of the contact stop all movements. The opening of the contact excludes all normal or emergency operations. <i>WARNING: when the contact closes again the door proceeds with the interrupted operation.</i>
1 — 28	N.O.	BLOCK EXCLUSION	The block operation is excluded when the contact is closed. The exclusion is automatic in the fully open and partial two-way positions with COMH, COMK and COME function selectors. <i>NOTE: if there is no blocking device and the function selector, make a jumper on terminals 1-28.</i> <i>NOTE: advanced command management is available with the MD1 display module.</i>
1 — 29	N.O.	POWER RESET	All acquired data is deleted when the contact is closed. The automation can start acquisition again after 3 seconds.
OPEN 	N.O.	OPENING	The opening operation is activated with a brief press.
		SETTINGS RESET	<ul style="list-style-type: none"> - Press the OPEN key for 4 s (IN LED flashes), - press the OPEN key within 4 s for another 2 s (the IN LED comes on). <p>The SETTINGS RESET deletes all the remote software settings made using COME, DMCS, MD1. After SETTINGS RESET it is possible to adjust the control panel directly.</p> <p>The SETTINGS RESET deletes the memory of MP1 module (if present).</p> <p><i>WARNING: if the MD1 display module or the MP1 accessory module are disconnected from the control panel, a SETTINGS RESET must be performed.</i></p>





WARNING: make a jumper for all the N.C. contacts if not in use. The terminals with the same number are equal.

4.1 Non-testable safety devices

Command	Function	Description
41  6	N.C. OPENING SAFETY	With DIP9=ON the opening of the contact decreases the opening speed in the last 500 mm of the door wing stroke. <i>NOTE: advanced command management is available with the MD1 display module.</i>
41  8	N.C. REVERSAL SAFETY CONTACT	With DIP9=ON the opening of the contact reverses movement (re-opening) during the closing operation.

4.2 Testable safety devices

Command	Function	Description
1  6	N.C. OPENING SAFETY	The opening of the contact decreases the opening speed in the last 500 mm of the door wing stroke. <i>NOTE: advanced command management is available with the MD1 display module.</i>
1  8	N.C. REVERSAL SAFETY CONTACT	The opening of the contact reverses movement (re-opening) during the closing operation.
41 	SAFETY TEST	With DIP9=ON connect terminal 41 of the control panel to the corresponding test terminal on the safety device. Terminal 41 activates a test of the safety device on each cycle. If the test fails the SA led flashes and the test is repeated.

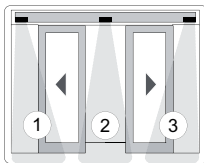

Autocontrolled safety devices can be connected as illustrated in the diagram.



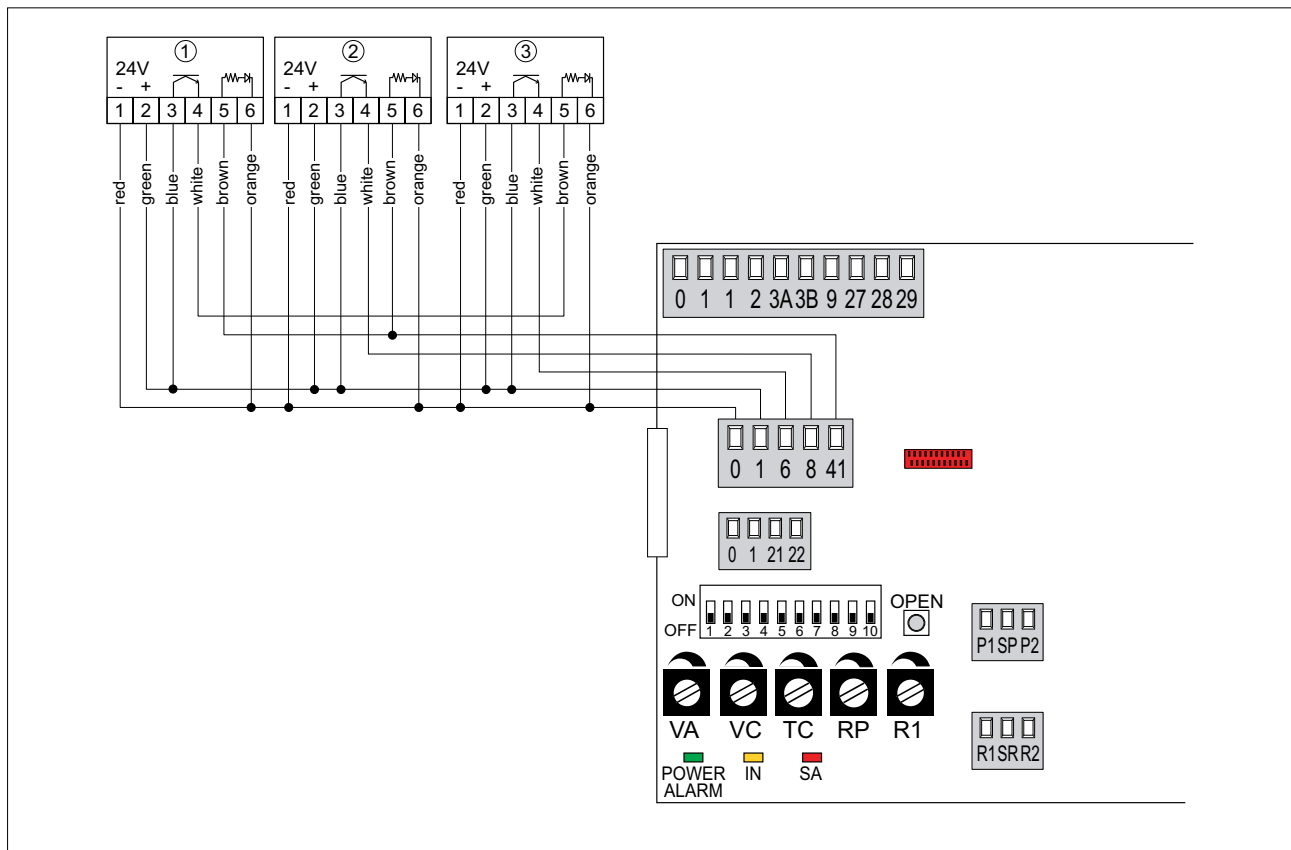

Set DIP10=ON on each PASAT3-PASAT3I.

Device 1 performs the safety on the left side during opening.

Device 2 performs the reverse safety contact on the passage opening during the closing operation. Device 3 performs the safety on the right side during opening.

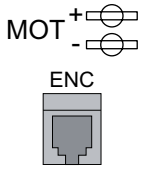

5. OUTPUTS AND ACCESSORIES

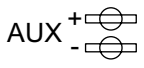
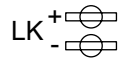
Output	Value - Accessories	Description
	24 V $\overline{\text{=}}$ 0.5 A	Accessories power supply. Power supply output for external accessories. <i>NOTE: the maximum absorption of 0.5 A corresponds to the sum of all terminals 1.</i>
	COME MD1 DMCS	Allows the connection of 1 or 2 COME function selectors or the MD1 display module, or the connection of the DMCS software, or the network connection of a maximum of 4 automations. <i>NOTE: use a data transmission type screened cable.</i>
	BIXMR2	It allows the operating configurations to be saved using the function SF \blacktriangleright SV of the MD1 display module. The saved configurations can be recalled using the function SF \blacktriangleright RC of the MD1 display module. If the control panel is replaced, the BIXMR2 storage module being used can be inserted in the new control panel. <i>WARNING: the storage module must be inserted and removed with the power supply disconnected.</i>
		Motor-encoder connection. Connect the motor and encoder to the control panel by means of the supplied cables.
	AL2 AL15	Power supply unit connection.
	VALABE 2 x 12 V 1.2 Ah REXAB 2 x 12 V 2 Ah	Anti-panic battery kit. With DIP3=OFF with the mains power supply off, the automation will carry out an opening operation at low speed. When the door is open, the power supply is disconnected from the control panel. To charge the batteries, connect the mains power and the battery kit at least 30 minutes before starting the system. <i>WARNING: the batteries must always be connected to the control panel for charging. Periodically check the efficiency of the batteries.</i>
	VALABC 2 x 12 V 7 Ah REXAB 2 x 12 V 2 Ah	Continuous mode battery kit. With DIP3=ON with the mains power supply off, the battery kit will guarantee continuous operating. With DIP4 select the last operation with the batteries flat. To charge the batteries, connect the mains power and the battery kit at least 30 minutes before starting the system. <i>WARNING: the batteries must always be connected to the control panel for charging. Periodically check the efficiency of the batteries.</i>
	REXLOKB VALLOKB 24 V $\overline{\text{=}}$ 200 mA	Bistable blocking device. Bistable blocking device power supply output (auxiliary coil).
	REXLOK REXLOKA VALLOK VALLOKA VALHLLOK 24 V $\overline{\text{=}}$ 1 A	Blocking device. Blocking device power supply output.

5.1 Limit switch connection

Command	Function	Description
1 — S1	N.O.	FUTURE USE
1 — S2	N.O.	FUTURE USE

5.2 CELPR photocells connection

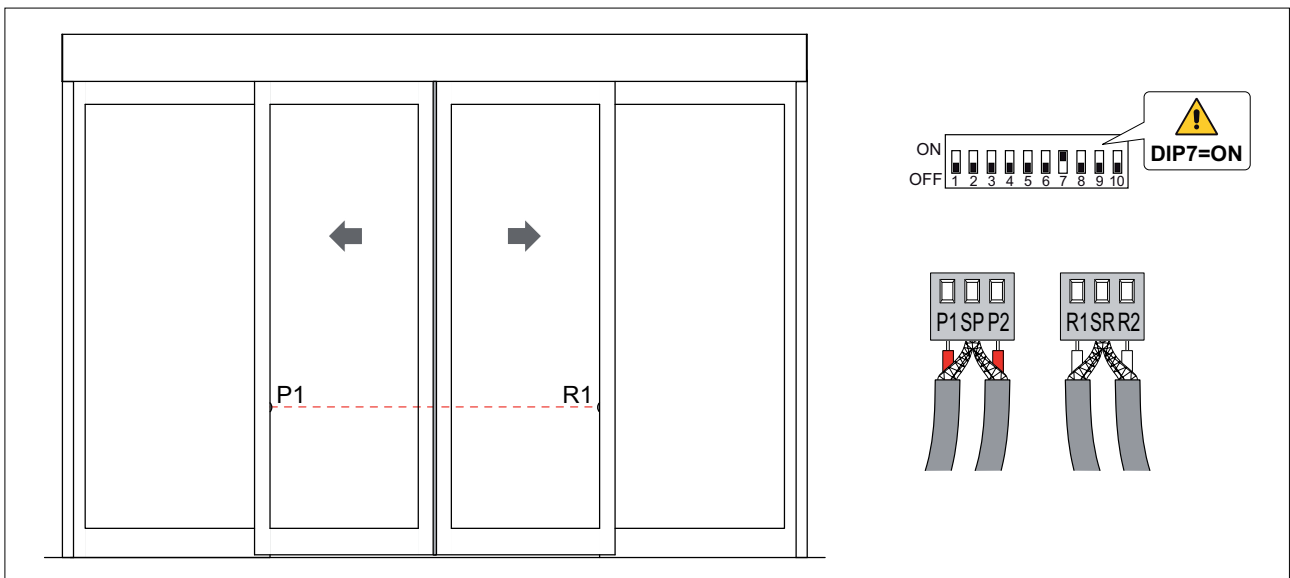
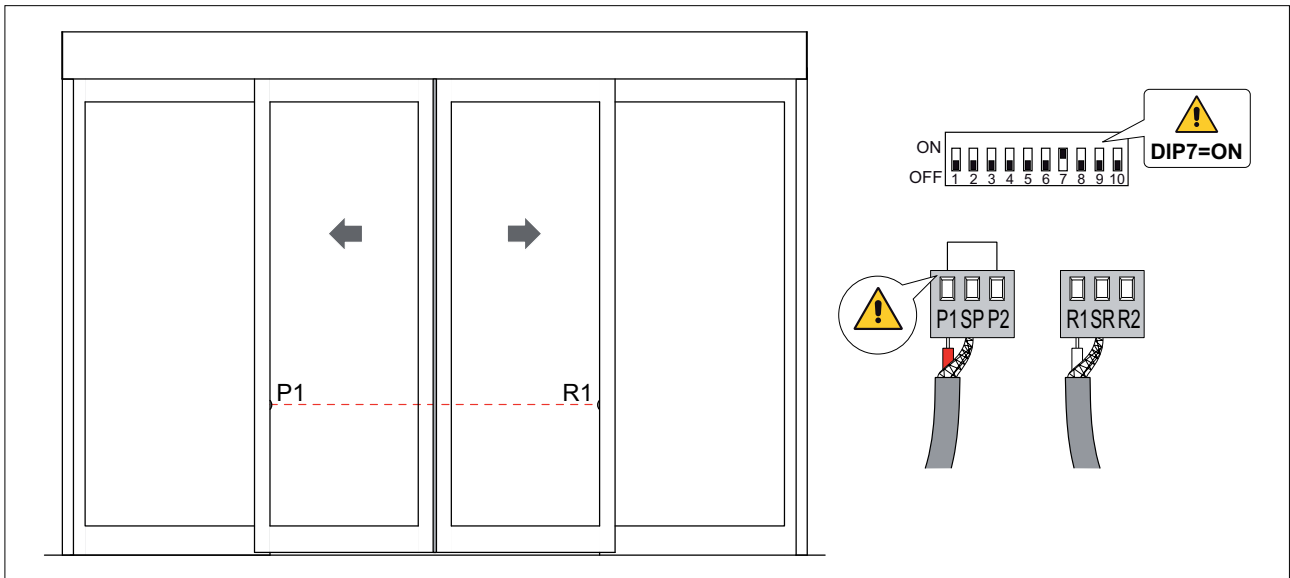

6. ELECTROMAGNETIC EMISSIONS





WARNING: in accordance with Directive 2004/108/EC, the supplied ferrites must be installed as shown on page 1.

Pass the cable through the ferrite, make 1 turn and protect it from knocks by using heat-shrink sheathing or similar.

The ferrite must be secured to the cable near the terminal boards (approximately 50 mm).

If the number of cables involved need to use several ferrites, KEMC2 kit is available for this purpose.









7. ADJUSTMENTS









	Description	OFF 	ON 
DIP1	Block type.	Normal block or bistable block.	Anti-panic block.
DIP2	Opening direction selection. The opening direction is intended by viewing the automation from the side being examined.	Right-hand opening for single door wing automations. Selection for double door wing automations.	Left-hand opening for single door wing automations.
DIP3	Batteries.	Anti-panic operation.	Continuous operation.
DIP4	Flat batteries.	Last operation closing.	Last operation opening.
DIP5	Door weight.	<200 kg [TEN-VALOR] <90 kg [REX]	>200kg [TEN-VALOR] >90 kg [REX]
DIP6	Selecting automation type.	TEN-VALOR	REX
DIP7	Integrated photocell.	Disabled.	Enabled.
DIP8	FUTURE USE	/	/
DIP9	Safety test terminal 41.	Disabled. With DIP9=OFF the safety sensors must be connected to terminals 1-6 and 1-8.	Enabled.
DIP10	FUTURE USE	/	/

7.1 Trimmer enabling procedure

The VA, VC and R1 trimmers affect the force limiting safety function. They must be set as instructed. If not, the modifications will not be accepted and the IN LED will flash.

- press the OPEN key for 4 s (IN LED flashes);
- set the VA, VC and R1 trimmers within a maximum time of 5 min;
- to complete the procedure, press the OPEN key for 2 s or wait for the maximum time to expire.

Trimmer	Description
VA 	Opening speed adjustment. Adjusts the opening speed.  WARNING: set the correct opening speed and check that the operating force and contact force between the door wing and the obstacle is lower than that indicated in the DIN 18650-1 standard.
VC 	Closing speed adjustment. Adjusts the closing speed.  WARNING: set the correct closing speed and check that the operating force and contact force between the door wing and the obstacle is lower than that indicated in the DIN 18650-1 standard.
TC 	Setting automatic closing time. Adjust the time that passes between the end of the opening operation and the start of the automatic closing operation.
RP 	Partial opening adjustment. Adjust the range when the command is given between 27-3A (3B). With the trimmer at minimum, the opening is equal to 5% of the normal opening; with the trimmer at maximum, the opening is equal to 90% of the normal opening.
R1 	Thrust on obstacles adjustment. The control panel is equipped with a safety device that stops motion if an obstacle is encountered during the opening operation and reverses motion during the closing operation. After the obstacle has been removed, the door automatically searches for the stop, continuing its stroke at the learning speed.  WARNING: set the correct opening and closing speeds and check that the operating force and contact force between the door wing and the obstacle is lower than that indicated in the DIN 18650-1 standard.

LED	On	Flashing
POWER ALARM 	Power supply on.	 Encoder not working or automation fault.
IN 	Receipt of a command 1-3A, 1-3B, 27-3A, 27-3B.	 Change in status of a dip switch or command 1-2.  SETTINGS RESET in progress.  Trimmer enabling procedure in progress.
SA 	At least one of the safety contacts is open.	 Safety test failure (terminal 41).

8. START-UP



WARNING: Before performing any type of operation, make sure that the automation is turned off and the batteries are disconnected.
The operations in point 4 are performed without safety devices.
The trimmer can only be adjusted with the automation idle.

- 1- Select the correct opening direction with DIP2.
- 2- Set TC trimmer to the minimum and VA, VC, RP and R1 trimmers halfway.
- 3- Make a jumper on the safety devices (41-6 and 41-8) and the stop (1-9).
Set DIP7=OFF.
- 4- Turn on the power (mains and batteries) and perform a SETTINGS RESET using the OPEN button as indicated on page 5.
WARNING: the control panel performs an automatic POWER RESET on each start and the first opening or closing manoeuvre is performed at low speed allowing the automatic self-learning of the stop positions (acquisition).
Check that the automation is operating correctly with further opening and closing commands and set the desired speed using the VA and VC trimmers.
WARNING: to set the VA, VC and R1 trimmers, the trimmers must be enabled as described on page 10.
- 5- Adjust the thrust on obstacles with R1 trimmer.
- 6- Remove the jumpers and connect the safety devices (41-6 and 41-8) and the stop (1-9).
If the CELPR photocells are present, set DIP7=ON.
- 7- Select battery operating using DIP3 and DIP4.
- 8- Adjust the automatic closing with the TC trimmer (enabled by command 1-2).
- 9- Set the partial opening using the RP trimmer if required.
- 10- Connect any accessories and check they operate correctly.
- 11- If the automation encounters an obstacle during a closing operation, the movement is reversed.
If the automation encounters an obstacle during an opening operation, movement is stopped.
If the obstacle is detected twice consecutively, it is considered as the new stop until it is removed.



WARNING: check the operating force and that the contact force between the door and the obstacle is lower than that indicated by the DIN 18650-1 standard.



NOTE: in the event of servicing or if the control panel is to be replaced, repeat the start-up procedure.

9. TROUBLESHOOTING

Problem	Possible causes	Remedy
The automation does not open or close or does not perform the set operations.	Function selector fault.	Perform the SETTINGS RESET using the OPEN button as indicated on page 5. <i>WARNING: this operation may cancel previously made remote adjustments.</i>
	Function selector incorrectly set.	Check and correct the function selector settings.
	Control panel internal fault. (POWER ALARM led flashing).	Perform the POWER RESET with command 1-29 as indicated on page 5, or via the functions selector (if present).
The automation does not open or close.	No power. (POWER ALARM led off).	Check that the control panel is powered correctly.
	Short circuited accessories. (POWER ALARM led off).	Disconnect all accessories from terminals 0-1 (voltage must be 24 V $\overline{\text{DC}}$) and reconnect one at a time.
	Blown line fuse. (POWER ALARM led off).	Replace F1 fuse.
	The stop contact is open.	Check terminal 9 of the control panel and the position of the function selector switch (if present).
	The automation is locked by bolts and locks.	Check that the door wings move freely.
	Safety contacts are open. (SA led on).	Check terminals 6 and 8 of the control panel.
	Photocells are activated. (SA led on).	Check that the photocells are clean and operating correctly.
	Incorrect DIP7 setting. (SA led on).	If DIP7=ON, check the effective connection of the CELPR photocells.
	The radars are activated.	Check that the radar is not subjected to vibrations, does not make false readings or the presence of moving objects within its range.
	The automatic closing does not work.	Check jumper 1-2 and the position of the function selector (if present).
External safety devices not activating.	Incorrect connections between the photocells and the control panel.	Connect N.C. safety contacts together in series and remove any jumpers on the control panel terminal board.
	Incorrect DIP9 setting. (SA led flashing)	Check the connections of the safeties as illustrated on page 6.
The automation opens by itself.	The radars are instable or detect moving objects.	Check that the radar is not subjected to vibrations, does not make false readings or the presence of moving objects within its range.

Problem	Possible causes	Remedy
The automation opens/closes briefly and then stops.	Encoder disconnected, false encoder contacts, encoder fault. (POWER ALARM led flashing).	Check that the encoder is connected correctly, clean the contacts by connecting and disconnecting the encoder plug on the contacts, replace encoder.
	Motor leads crossed. (POWER ALARM led flashing).	Check the motor leads.
	There is a presence of friction.	Manually check that the door wings move freely and adjust the door wing in height by lifting it.



NOTE: if the MD1 display module is present, consult the **Visualization of alarms and faults** chapter in the relative installation manual.

10. EXAMPLE APPLICATION WITHOUT FUNCTION SELECTOR

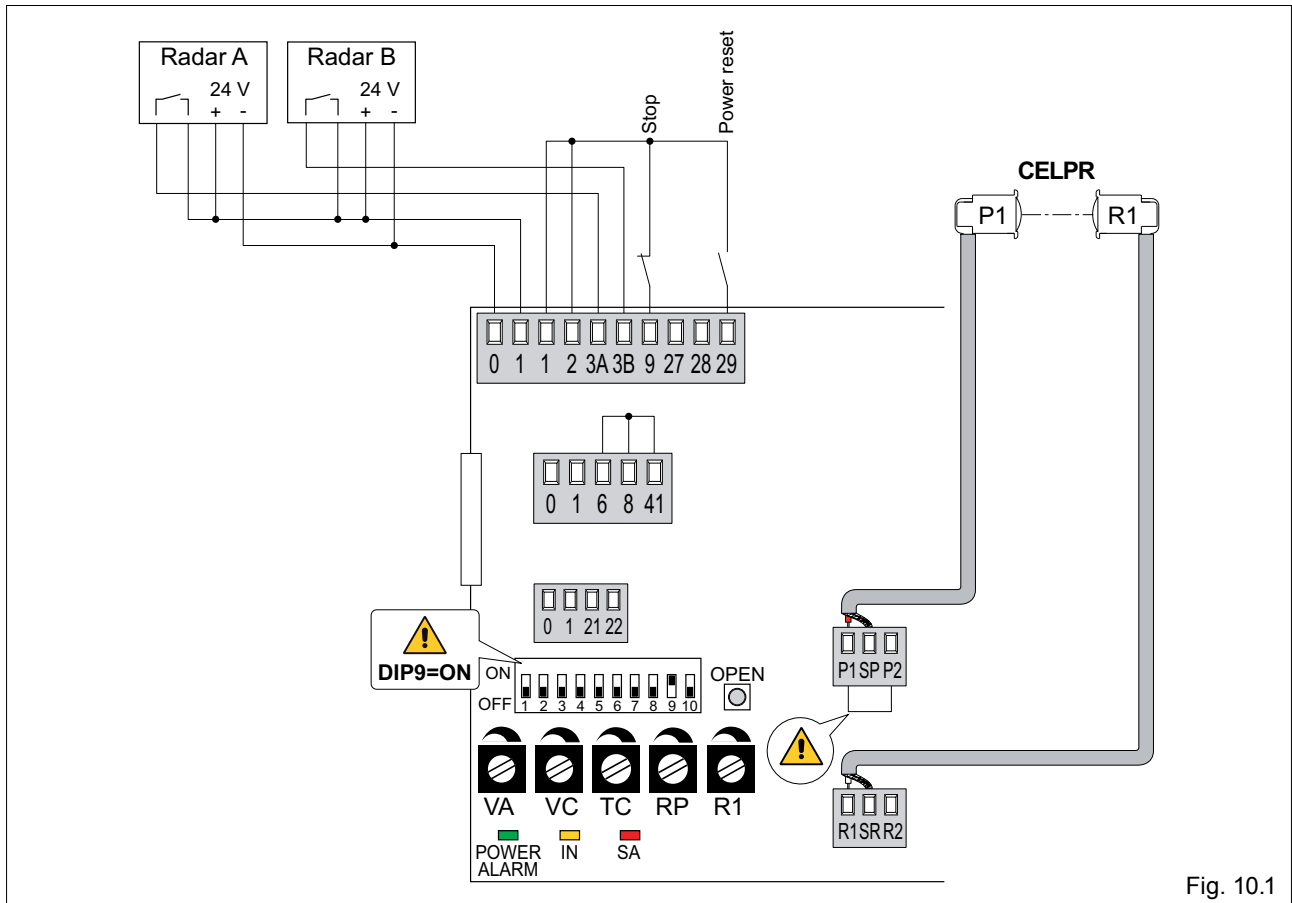

Fig. 10.1

The automation opens with commands 1-3A, 1-3B of the radar, and automatically closes with jumper 1-2. Make the safety on the passage opening with CELPR photocells. The switch between 1-9 stops the automation at that point and no other normal or emergency operation is permitted. Contact 1-29 can be used for the POWER RESET of the control panel.

11. EXAMPLE APPLICATION WITH COMH-COMK FUNCTION SELECTOR

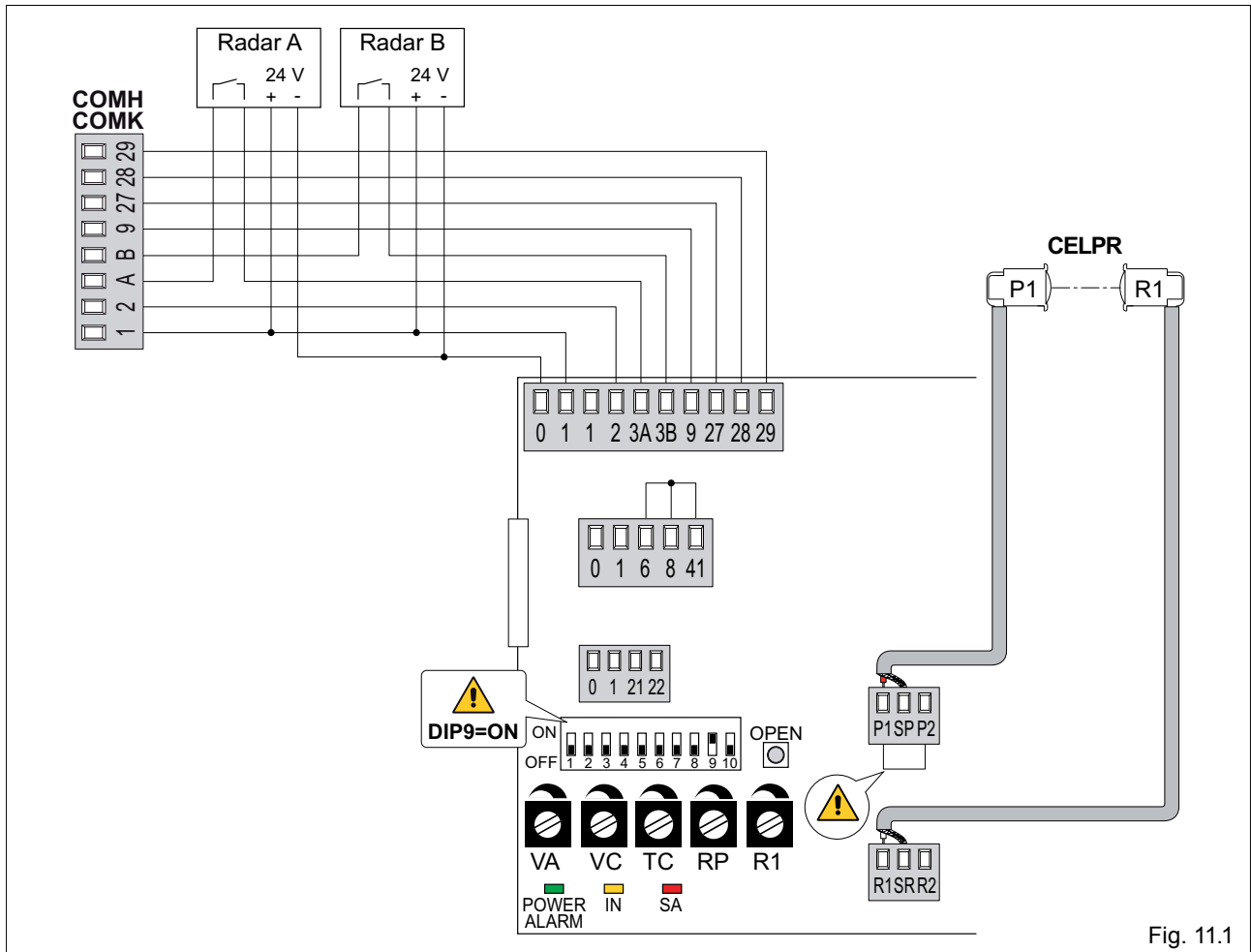

Fig. 11.1

The automation opens with the 1-3A, 1-3B radar commands and automatically closes based on the operation chosen on the COMH-COMK function selector. Make the safety across the passage opening with the CELPR photocells.

With the COMH-COMK function selector in the STOP position all normal and emergency operations are excluded.

Contacts 41-6 and 41-8 are independent from the COMH-COMK function selector, therefore they must have jumpers if not in use.

The POWER RESET of the control panel is available on the COMH-COMK function selector.

12. EXAMPLE APPLICATION WITH COME FUNCTION SELECTOR

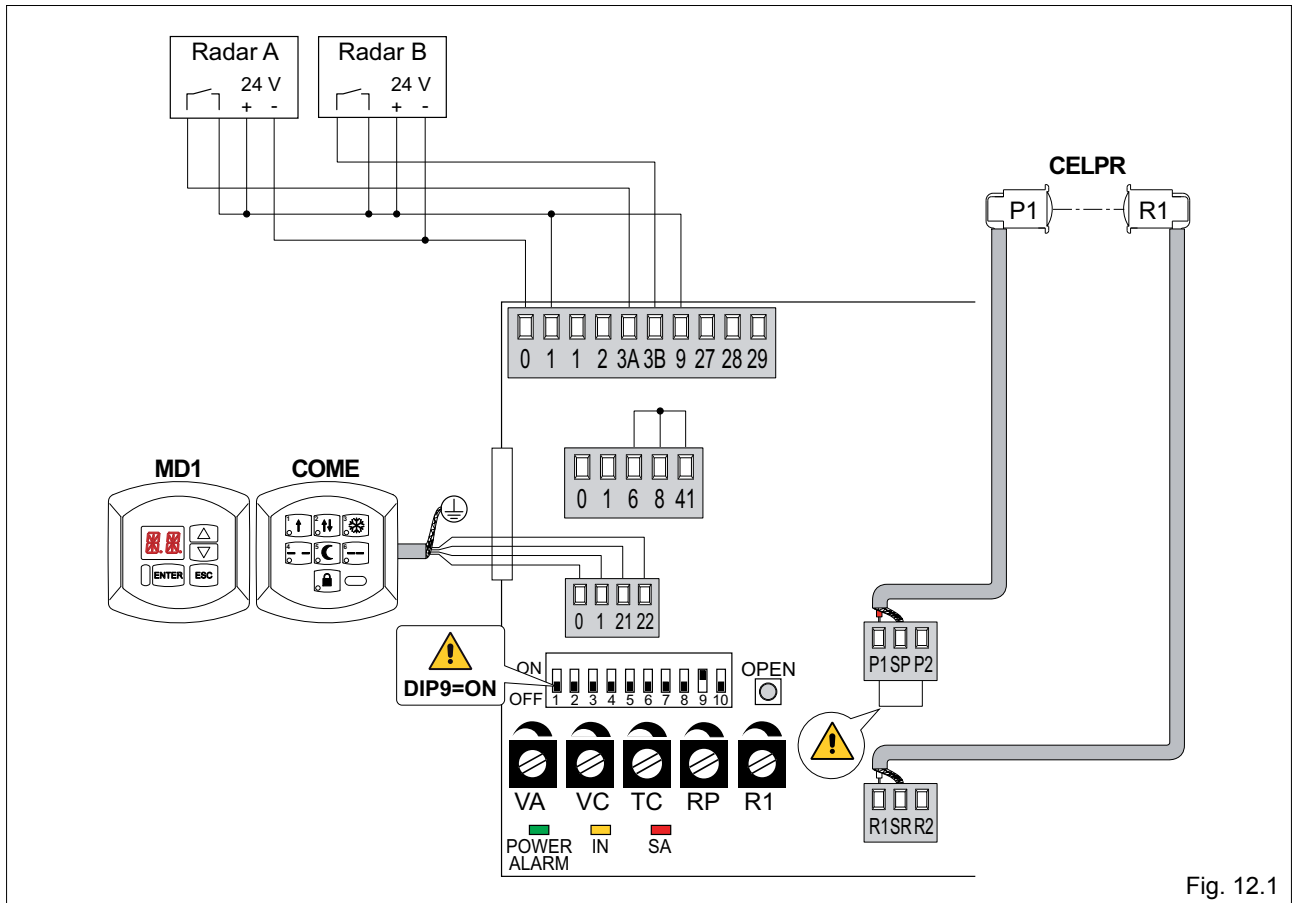

Fig. 12.1

The automation opens with the 1-3A, 1-3B radar commands and automatically closes based on the operation chosen on the COME function selector. Makes the safety across the passage opening with the CELPR photocells.

With the COME function selector in the STOP position all normal and emergency operations are excluded. Contacts 41-6 and 41-8 are independent from the COME function selector, therefore they must have jumpers if not in use.

Contact 1-9 is in series to the STOP, COME function selector set, therefore it must have a jumper if not used. The POWER RESET of the control panel is available on the COME function selector through a key combination.

A MD1 display module can be connected to access the adjustment and the diagnosis of the control panel.



DITEC S.p.A. Via Mons. Banfi, 3 21042 Caronno P.Ia (VA) Italy Tel. +39 02 963911 Fax +39 02 9650314
www.ditec.it ditec@ditecva.com

DITEC BELGIUM LOKEREN Tel. +32 9 3560051 Fax +32 9 3560052 www.ditecbelgium.be **DITEC DEUTSCHLAND** OBERURSEL
Tel. +49 6171 914150 Fax +49 6171 9141555 www.ditec-germany.de **DITEC ESPAÑA** ARENYS DE MAR Tel. +34 937958399
Fax +34 937959026 www.ditecespana.com **DITEC FRANCE** MASSY Tel. +33 1 64532860 Fax +33 1 64532861 www.ditecfrance.com
DITEC GOLDPORTA ERMESINDE-PORTUGAL Tel. +351 22 9773520 Fax +351 22 9773528/38 www.goldporta.com **DITEC SWITZERLAND**
BALERNA Tel. +41 848 558855 Fax +41 91 6466127 www.ditecswiss.ch **DITEC ENTRE/MATIC NORDIC** LANDSKRONA-SWEDEN
Tel. +46 418 514 50 Fax +46 418 511 63 www.ditecentrematicnordic.com **DITEC TURCHIA** ISTANBUL Tel. +90 21 28757850
Fax +90 21 28757798 www.ditec.com.tr **DITEC AMERICA** ORLANDO-FLORIDA-USA Tel. +1 407 8880699 Fax +1 407 8882237
www.ditecamerica.com **DITEC CHINA** SHANGHAI Tel. +86 21 62363861/2 Fax +86 21 62363863 www.ditec.cn