



Tusker

We do it all!

MURF

We design and deliver
YOUR MRF - YOUR WAY!

Tusker [group.co.uk](http://tuskergroup.co.uk)

Tusker

Waste management and recycling is a growing industry and at Tusker, we are proud to be at the fore-front, providing innovative end-to-end solutions for even the most challenging projects for this sector.

As a family business with 30 years experience, we are proud of our reputation delivering exceptional quality to globally recognised standards, with a proven track record for repeat business from satisfied clients. Our reliability and adaptability means there is no project beyond our scope.

Complex and demanding projects are what we thrive on and our success is underpinned by the great relationships we build with our clients, who trust us to deliver on their vision.





We
do it all!

Why Tusker

Our clients love our adaptability, our can-do attitude backed-up by a team of highly skilled, talented workers, our ability to embrace innovation and our passion and commitment to delivering the highest standards of quality.

Our end-to-end solutions from design, detailing and prototyping to fabrication, facility build, equipment installation, commissioning and complete on-site support, means we are with you every step of the way.

A crucial part of this integrated service is our extensive fleet of cranes and haulage equipment, which play a vital role in ensuring seamless project execution. “We Do It ALL” is not just a motto—it’s the way Tusker delivers exceptional value to clients by managing every aspect of the project, including the critical lifting and transportation needs.

The logo for MURF (Material Recovery Facility) is displayed in large, bold, white capital letters. The letter 'U' is highlighted in a vibrant green color and features a white recycling symbol (three chasing arrows forming a triangle) positioned above it. The background of the slide is a photograph of a large, dark industrial building with a light-colored sky above and a paved area in the foreground. Two yellow bollards are visible in front of the building's entrance.

MURF

Your MRF Your Way!

Our “Your MRF, Your Way” approach, focuses on tailoring every aspect of your Material Recovery Facility to your exact needs.

Tusker provides end-to-end solutions, from greenfield site to a fully commissioned and complaint plant, ensuring a seamless transition for you and your business:-

- Bespoke Design
- Process Building
- Plant Construction
- Logistics and Installation
- Commissioning and Handover
- 24/7 Plant Support

For more information email info@tuskergroup.co.uk

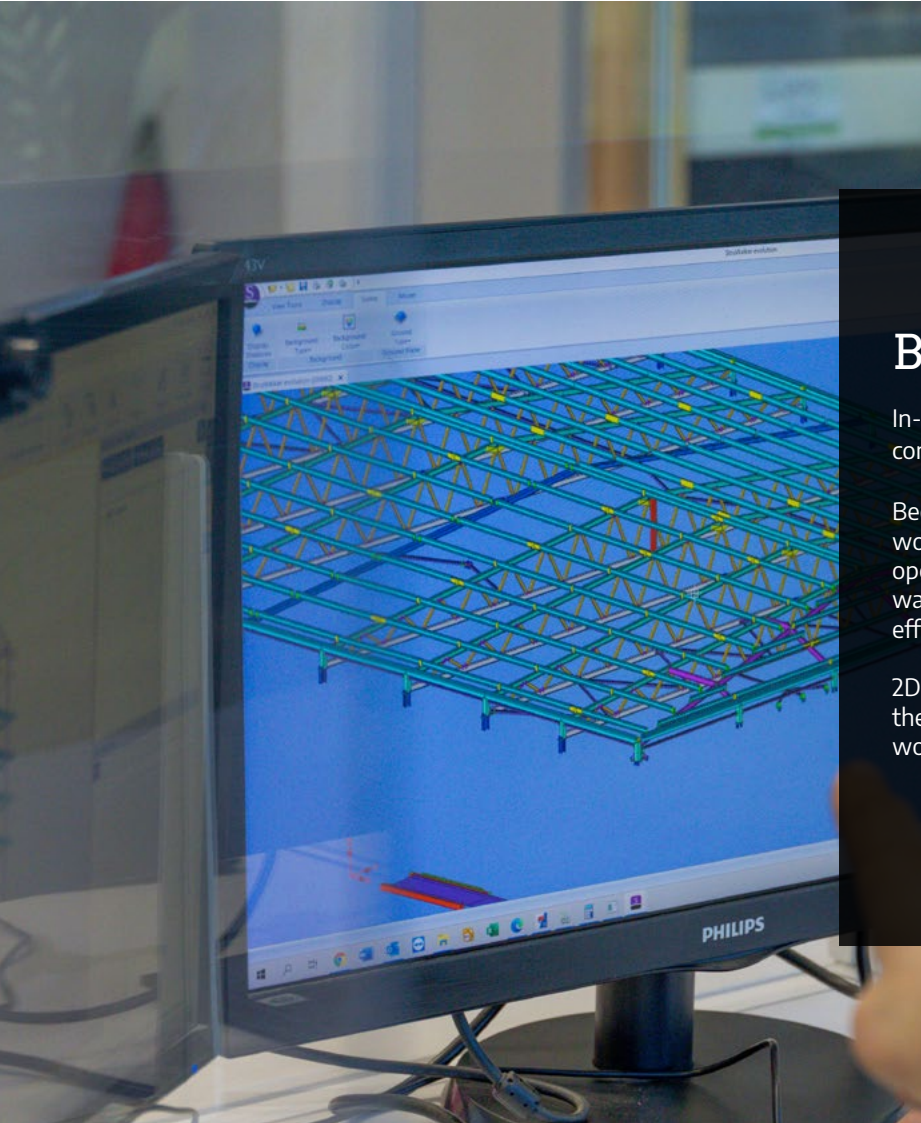

Bespoke Design

In-house bespoke design and detailing of complete waste management solutions.

Because all businesses have different needs, we work in consultation with you to design a bespoke operating system and plant facility that will maximise waste recovery and recycling for you in the most efficient and sustainable manner.

2D and 3D renderings allow you to fully interpret the facility and ensure everything is just how you would like it to be - Your MRF Your Way.

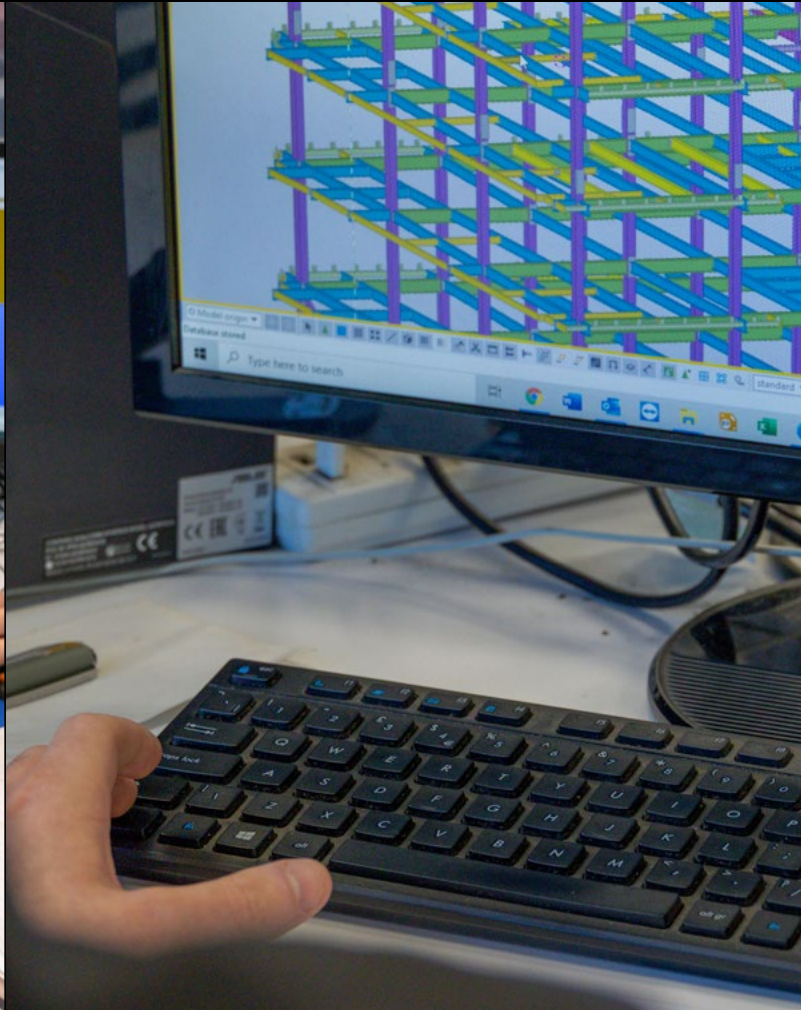
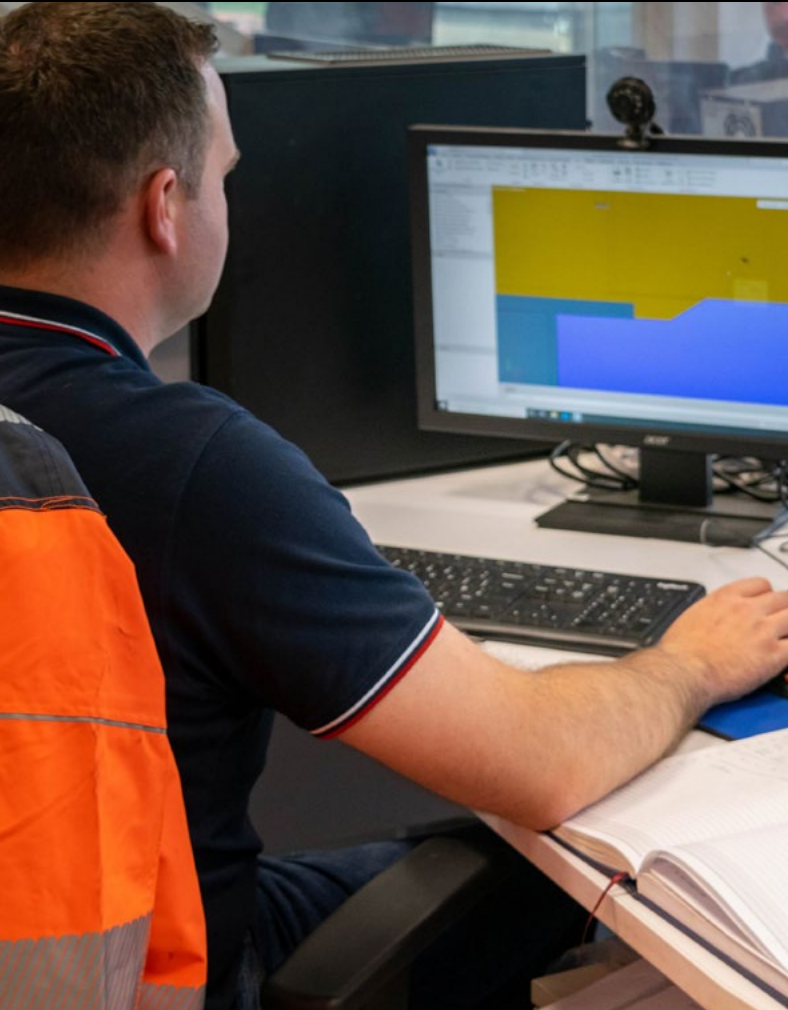

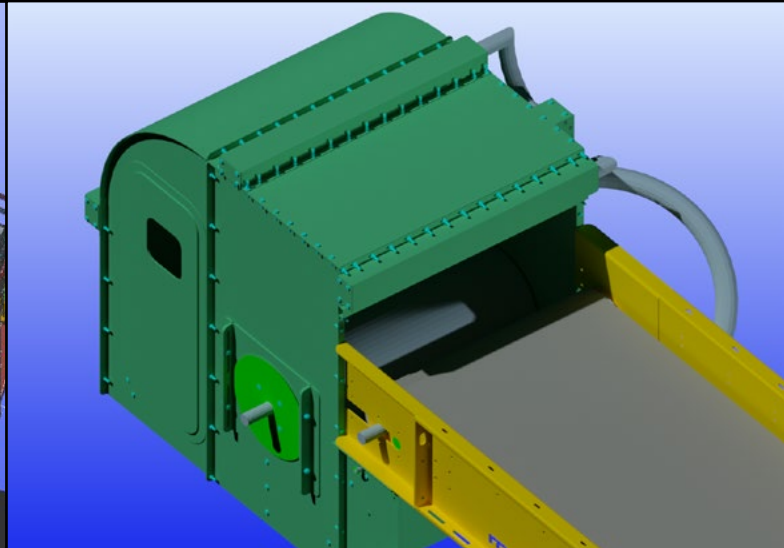
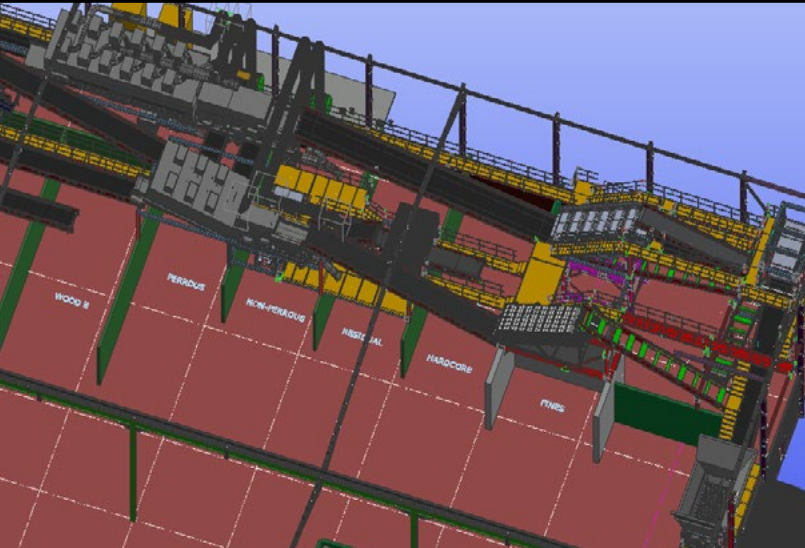
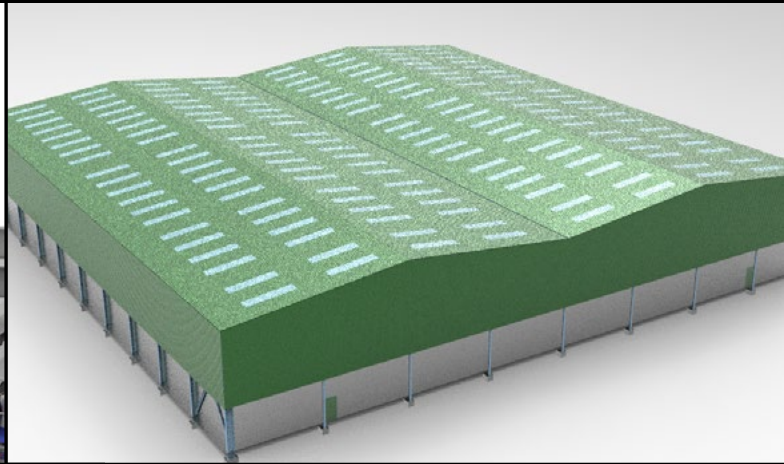
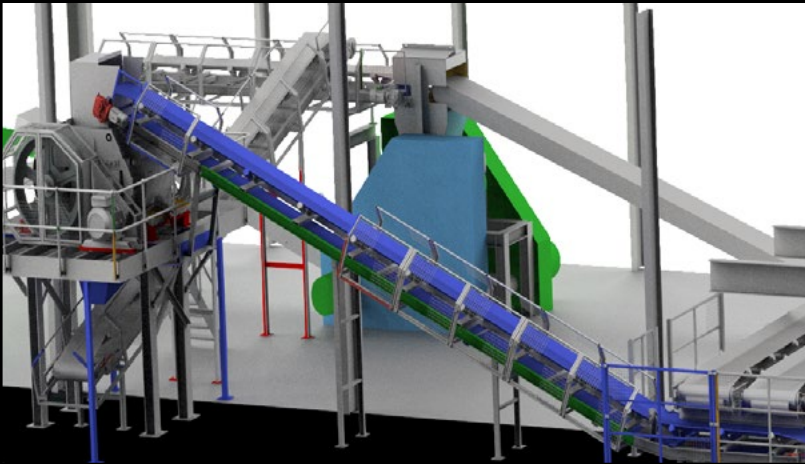



Process Building

Our comprehensive services go beyond bespoke design and include fabricating of process plant components such as, trommels, flat belt conveyors, slat conveyors, troughing set conveyors, paddle mixers, windshifters, finger screeners and more.

Within our 80,000sqft state-of-the-art manufacturing facility, we also manufacture the structural steel with precision engineering for your plant to Execution Class 4 standards.

We ensure that every aspect of your MRF is built to the highest standards of quality and safety. We guarantee a facility that is not only efficient and customized but is also fully compliant with the most stringent industry standards and regulations.





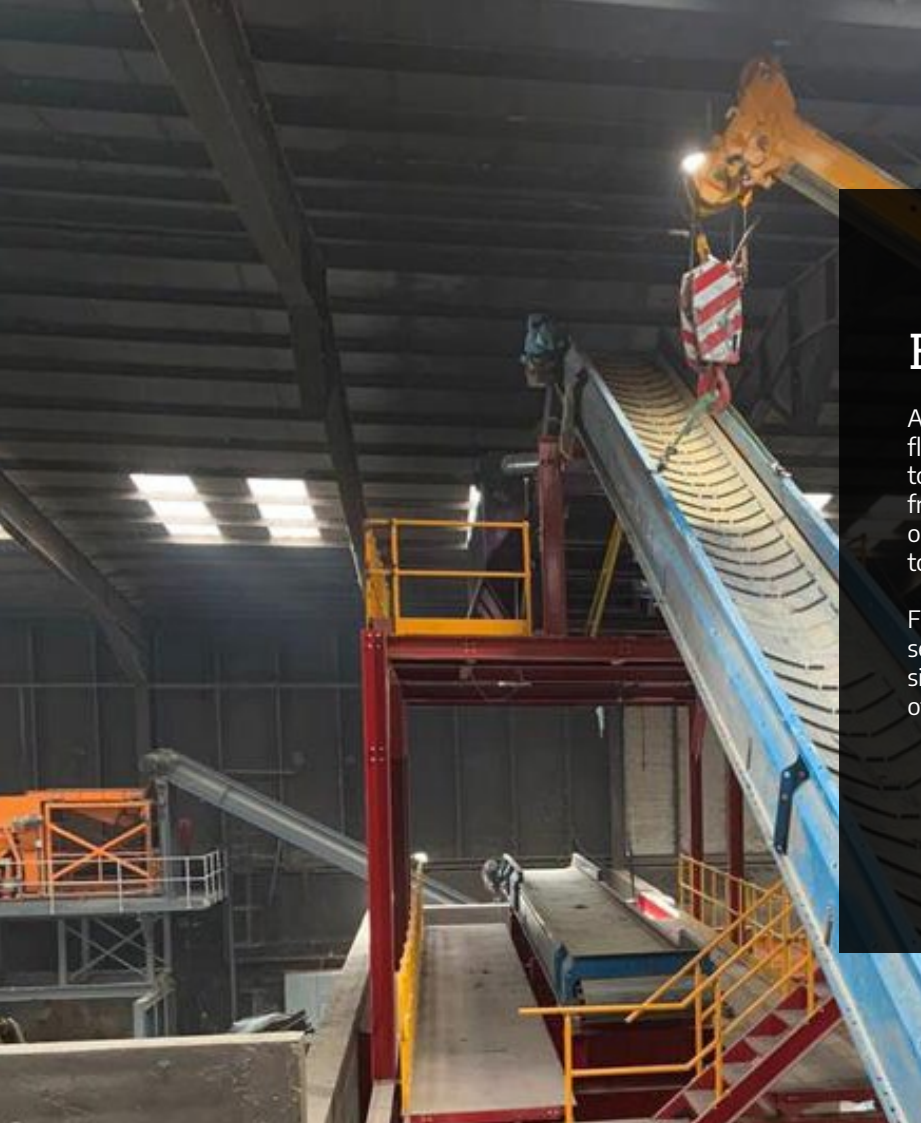

Plant Construction

As part of our end-to end solution, our fleet of low loaders, extendable trailers (up to 100ft) and tippers transports your steel frame components to site for erection with our mobile telescopic cranes and self-erect tower cranes.

From there, Tusker provides a full build service with excellent craftsmanship - from site clearance and foundations to erection of your bespoke plant facility.



Plant Construction





Logistics & Installation

Our haulage services which operates across the UK, coordinates the logistics of transporting materials and equipment to any location. This nationwide service ensures that your project stay on schedule, with all necessary components delivered as needed.

Tusker's crane and haulage services are fully integrated with our other offerings, ensuring seamless coordination between fabrication, delivery, and installation. This eliminates the need for multiple contractors, reducing complexity and improving efficiency.







Commissioning

Tusker handles the full commissioning of your process plant. This involves rigorous testing and calibration to ensure that all systems are fully operational, optimized, and compliant with industry standards and is regulation compliant.

Commissioning is the final step before the plant is handed over, guaranteeing that your facility is ready for immediate operation.



Commissioning and Handover

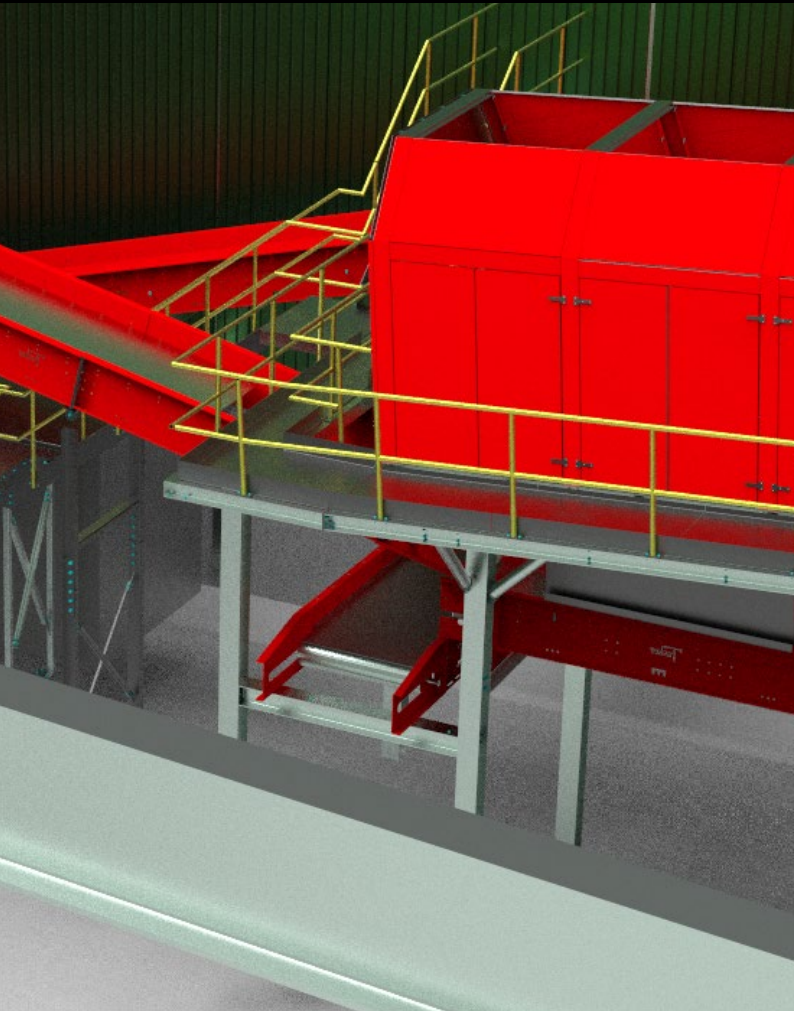

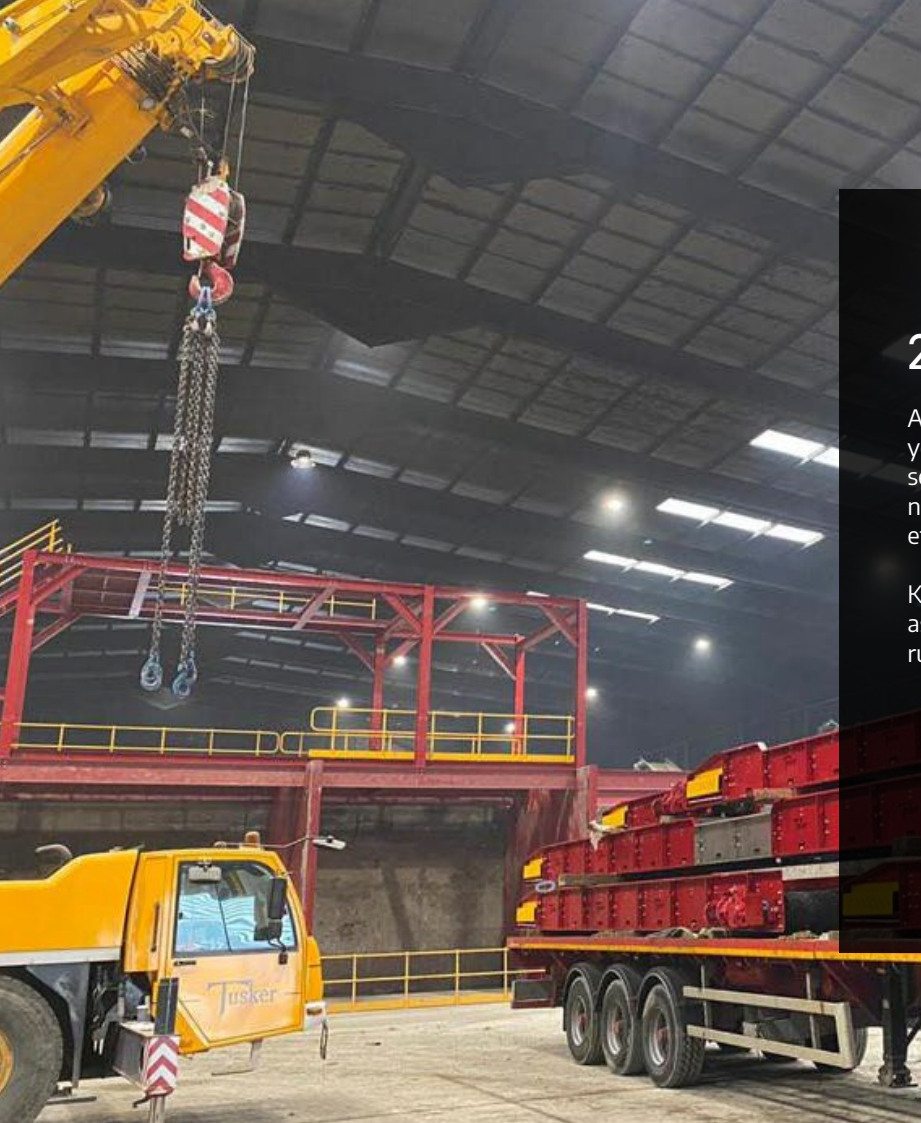

24/7 Support

After installation, Tusker continues to support you and your facility, offering maintenance services, compliance checks, and updates as needed to ensure long-term operational efficiency and regulatory adherence.

Knowing that we do it all, gives you total assurance that with Tusker, you can build and run your MRF your way!









EA Compliance

At Tusker, we know that keeping up with regulations can be challenging, and that is where we come in.

You can rely on our expertise to help you achieve full EA compliance of your existing facility - with plant upgrades, design and supply of new process buildings in live environments, retrofitting and structural repairs.

Now you can run your business with total peace of mind.

For more information email info@tuskergroup.co.uk

Before



After





What our clients say

"We were impressed with Tusker's design and build capability and support team. Everything went smoothly from start to finish. Very efficient and reliable company."

Agnail Group

"A quality job from a company that designed, manufactured and installed our new highly effective equipment which has enhanced the efficiency of our process. And they made it look easy. Great job guys!"

Beauparc Group

"Exceptional company to deal with, speed quality and price are outstanding. Fantastic team to deal with."

CWM Environmental

"Excellent company to deal with."

Bennett Construction

"We have found John and his team at Tusker to be ingenious problem solvers for several difficult projects. They really were with us every step of the way. Very happy with the results which have helped increase our throughput."

Kingscourt Brick

"Eamon and his team operate everything in a very professional manner, are very reliable, provide honest advice and assessments, and deserve to be acknowledged for all their achievements."

Valencia Waste



We design and deliver
YOUR MRF - YOUR WAY!



Tusker Ireland

Tusker Head Office

Lough Egish,
Co. Monaghan,
A75 NP92,
Ireland

Tel +353 (0) 42 974 5071

Email waste@tusker.ie

Tusker Manufacturing

Tusker,
Co. Monaghan,
A75 N520,
Ireland

Tusker UK

Tusker UK Office

Cambridge Rd
Harrogate
HG1 1PB
United Kingdom

Tel +44 (0) 7 585294994

Email info@tuskergroup.co.uk

Tusker NI Crane Depot

181 Concession Road,
Crossmaglen, Newry,
GB35 9JB
United Kingdom

tuskergroup.co.uk