



CONTENTS

1. Applications	Pag.17	9. Spare part list	Pag.25
2. Technical characteristics	Pag.17	10. Impeller replacement	Pag.26
3. Technical datas	Pag.18-19	11. Replace oil	Pag.26
4. Overall dimensions	Pag.20-21	12. Double mechanical seal replac.	Pag.27
5. Installation	Pag.22	13. Tools	Pag.28
6. Electrical connections	Pag.23	14. Troubles and remedies	Pag.28
7. Operating rules	Pag.24	15. EC Declaration of conformity	Pag.28
8. Inspection and maintenance	Pag.25	Interventions recording	Pag.29

EXPLANATION PLATE

DRENO 		MONSELICE - PD MADE IN ITALY			
Type : 1		S/N° 2			
P ₂ 3	kW 4	V 4	~		
Hz 5	°C 6	A 7	μF 8		
cos φ 9	10 CLASS F IP 68		N/1'	11	
Q l/min 12	Hm 13	14 	20m	Kg 15	

1	Electropump type
2	Serial number
3	Max power at motor shaft P2
4	Voltage rating
5	Frequency
6	Max permissible liquid temperature
7	Nominal absorption
8	Capacitor
9	Power factor
10	Insulation class and motor protection
11	R.P.M
12	Capacity
13	Head
14	Maximum depth of immersion
15	Pump weight

Warranty

The warranty terms and conditions of the products are listed in Dreno Pompe's general conditions of sale that are here referred to in full.

Without prejudice to the limitation and prescription terms provided by the above-mentioned general conditions of sale and as chosen by Dreno, the warranty provides for the replacement or repair of the product recognized by Dreno itself as faulty. It is understood that, if no replacement is available or no repair can be organized, Dreno Pompe will issue a credit note for the amount of the products recognized as faulty.

Without prejudice to the above and the cases of exclusion of the warranty provided for in Dreno's general conditions of sales, the warranty does not apply when:

- The products have been used in a manner not consistent with the instructions given in this manual or provided by Dreno Pompe;
- The products have been arbitrarily modified by the customer without Dreno Pompe's previous written authorization;
- The products have not been maintained in compliance with the schedule stated in this manual.

1. Applications

The heavy built portable submersible electric motor pumps “DRENO POMPE” of the series Compatta (EVO), BIC (EVO), Alpha-V (EVO), AM-AT, DNA, DNB are used in the domestic and industrial field, for pumping of raw and waste waters, stirred sludge, raw sludge, rotten sludge and mixed waters.

Maximum temperature of the pumped liquid: + 40°C with the pump completely submerged.

Maximum submersion depth: 20 m

Minimum submersion depth: check the size B on Paragraph 4 (Overall dimensions)

H-value of pumped liquid: 6 -11

Liquid density: lower as 1100 kg/m. The pumped liquid may contain suspended solid particles up to the diameters allowed by the impeller design:

Type	Free Passage Ø mm	Type	Free Passage Ø mm	Type	Free Passage Ø mm
Compatta 1-1,5	30	BIC 32-2/025-0,37	8x10	DNB 80-2-4/..	70
Compatta *(EVO) 2-3	40	BIC *(EVO) 32-2/056-075	20x10	AM-AT 40/2/110 C.218	20x10
DNA 50-2-4/..	50	Alpha V *(EVO) 22-32	40	AM-AT 40/2/110 C.219	20x10
DNA 65-2/..	65	Alpha V *(EVO) 4-55	45	GRIX 32-2/090-110-140	-
DNA 80-2-4/..	80	DNB 65-2-4/..	50	APX 32-2/..	20x10

*EVO version with double mechanical seals in oil chamber:

The electropump must not be used either in places with danger of explosion or fires, or for pumping inflammable liquid. For different applications of the pump, contact “DRENO POMPE Srl” for information.

2. Technical characteristics

Materials

The construction materials of each component have been chosen with particular attention to obtain high reliability and durability, that will last even in high-stress situations.

The components of the electropumps of the series Compatta (EVO), BIC (EVO), Alpha-V (EVO), AM-AT, DNA, DNB have got the motor cover (where provided), the motor casing, the oil chamber flange, oil chamber closing cover, the body pump, the body closing cover and the impeller made of cast iron GG 25; the motor shaft of stainless steel AISI420, screws AISI 304, O’Rings of nitrile NBR 70 and the handle of hard nylon Compatta (EVO), Alpha V (EVO) - Alpha (EVO).

Ball Bearings

The upper and lower ball-bearings are radial with a single row of balls. The ball-bearings are prelubricated and must be changed after a long period of time.

Electric motor

The electric motors are asynchrone 2 and 4 poles, monophase or threephase, with squirrel-cage rotor.

For the Monophase tension 230V, the available powers start from 0.28 up to 1.5 kW included, while for the Threephase tensions 400V, the available powers start from 0.28 up to 2.2 kW included.

The frequency is of 50 Hz.(On request we can supply also the 60Hz).

These motors are projected to output the maximum nominal power with variations up to 5% of the nominal tension and 2% of the nominal frequency Hz.

All the stators are built with insulation class F (155°C) and protection degree IP 68; they can be used with surrounding liquid temperature of 40°C. Monophase windings are equipped with thermal overload protection to avoid the motor to rise the limit temperature fixed to 130°C. The thermal overload protections are bimetallic switches, inserted in the windings, normally closed and rising the temperature of 130°C they open, stopping the power supply of the pump. When this protections are cooled (75°C) the power supply of the pump start again. The cooling is provided by the liquid the pump is submerged.

Electric Cable

The standard electric cable is H07RN8F 10 metres long.

The electropumps with Monophase motor have been equipped with Schuko-plug, DNA - DNB 4 poles and GRIX 32-2/090-110-140 M excluded, as they are supplied with control box, while the Threephase pumps are supplied with free terminals.

Mechanical seal

The series Compatta, Alpha V, BIC, AM-AT, have a mechanical seal (impeller side) and lip seal (motor side). The series GRIX and APX have a mechanical seal on oil chamber (Impeller side) and lip seal (motor side).

The series DNA, DNB and *(EVO) version have a double mechanical seal in oil chamber:

Motor side: carbon/ceramic (CA/CE/Viton).

Motor impeller: carbon ceramic/silicon carbide (SIC/SIC/Viton).

3. Technical datas

Type	DN GAS	R.P.M min-1	Power		Absorption			Cable Weight	Weight
			kW	Hp	1 - Phase		3 -Phase		
					230 V	μ F	400 V		
Compatta 1 M	1" ¼	2850	0,25	0,4	1,9	7,5	-	(1)-(2)	11
Compatta 1.5 M-T	1" ¼	2850	0,37	0,5	3,5	10	1,2	(1)-(2)	11,5
Compatta *(EVO) 2 M-T	1" ½	2850	0,56	0,75	3,5	16	1,7	(1)-(2)	17,5
Compatta *(EVO) 3 M-T	1" ½	2850	0,75	1	5	18	1,8	(1)-(2)	18
Compatta *(EVO) 22 M-T	2"	2850	0,56	0,75	3,6	16	1,7	(1)-(2)	19
Compatta*(EVO) 32 M-T	2"	2850	0,75	1	5,2	18	1,9	(1)-(2)	19,5
Compatta *(EVO) 4 M-T	2"	2850	1,1	1,5	7,6	25	2,9	(1)-(2)	21,5
Compatta *(EVO) 55 M-T	2"	2850	1,5	2	9,8	30	3,6	(1)-(2)	23
Alpha V *(EVO) 2 M-T	1" ½	2850	0,56	0,75	3,4	16	1,6	(1)-(2)	18
Alpha V *(EVO) 3 M-T	1" ½	2850	0,75	1	4,3	18	1,8	(1)-(2)	19
Alpha V *(EVO) 22 M-T	2"	2850	0,56	0,75	3,6	16	1,7	(1)-(2)	18
Alpha V *(EVO) 32 M-T	2"	2850	0,75	1	5,2	20	1,9	(1)-(2)	19
Alpha V *(EVO) 4 M-T	2"	2850	1,1	1,5	7,5	25	2,9	(1)-(2)	22,5
Alpha V *(EVO) 55 M-T	2"	2850	1,5	2	9,8	30	3,6	(1)-(2)	23
BIC *(EVO) 40-2/056 M-T	1" ½	2850	0,56	0,75	3,4	16	1,6	(1)-(2)	18
BIC 32-2/028 M-T	1" ¼	2850	0,28	0,4	1,9	7,5	-	(1)-(2)	11
BIC 32-2/037 M-T	1" ¼	2850	0,37	0,5	3,5	10	1,2	(1)-(2)	11,5
BIC *(EVO) 40-2/075 M-T	1" ½	2850	0,75	1	5	18	1,8	(1)-(2)	18
BIC *(EVO) 50-2/0110 M-T	2"	2850	1,1	1,5	7,6	25	2,9	(1)-(2)	21,5
BIC *(EVO) 50-2/0150 M-T	2"	2850	1,5	2	7,6	25	2,9	(1)-(2)	23
AM-AT 40/2/110 C.218	1" ½	2850	0,55	0,75	3,5	16	1,6	(1)-(2)	18,5
AM-AT 40/2/110 C.219	1" ½	2850	0,75	1,0	4,5	20	2,0	(1)-(2)	19
DNA 50-2/110 M-T	DN50	2850	1,1	1,5	7,4	25	2,7	(1)-(2)	26
DNA 50-2/150 M-T	DN50	2850	1,5	2	9,9	30	3,6	(1)-(2)	28
DNA 50-2/220 (-1) T	DN50	2850	2,2	3	/	/	5,2	(3)	32
DNA 50-4/090 M-T	DN50	1450	0,9	1,2	5	55	3	(3)	32
DNA 65-2/110 M-T	DN65	2850	1,1	1,5	7,4	25	2,7	(1)-(2)	29
DNA 65-2/150 M-T	DN65	2850	1,5	2	9,9	30	3,6	(1)-(2)	32
DNA 65-2/220 T	DN65	2850	2,2	3	/	/	5,2	(3)	35
DNA 80-2/110 M-T	DN80	2850	1,1	1,5	7,4	25	2,8	(1)-(2)	32
DNA 80-2/150 M-T	DN80	2850	1,5	2	9,9	30	3,6	(1)-(2)	34
DNA 80-2/220 T	DN80	2850	2,2	3	/	/	5,3	(3)	38
DNA 80-4/090 M-T	DN80	1450	0,9	1,2	5	20	3	(3)	38
DNB 65-2/080 M-T	DN65 -G2"	2850	0,8	1,1	5	18	2,1	(1)-(2)	21
DNB 65-2/110 M-T	DN65 -G2"	2850	1,1	1,5	7,4	30	2,7	(1)-(2)	29

TIPO	DN GAS	R.P.M min-1	Potenza		Assorbimento			Cavo	Peso
			kW	Hp	1 -FASE		3 -FASE		
					230 V	μ F	400 V		
DNB 65-2/150 M-T	DN65 -G2"	2850	1,5	2	9,9	32	3,6	(1)-(2)	31
DNB 65-2/220 T	DN65 -G2"	2850	2,2	3	/	/	5	(3)	35
DNB 65-2/220-1 T	DN65 -G2"	2850	2,2	3	/	/	5,2	(3)	36
DNB 65-2/220-2 T	DN65 -G2"	2850	2,2	3	/	/	5,2	(3)	36
DNB 80-2/150 M-T	DN80	2850	1,5	2	9,9	32	3,6	(1)-(2)	34
DNB 80-2/220 T	DN80	2850	2,2	3	/	/	5,2	(3)	40
DNB 80-2/220-1 T	DN80	2850	2,2	3	/	/	5,2	(3)	40
DNB 80-4/110 M-T	DN80	1450	1,1	1,5	7,6	25	3,1	(3)	43
GRIX 32-2/090 M-T	1"1/4	2850	0,9	1,2	5	25	2,1	(1)-(2)	20
GRIX 32-2/110 M-T	1" ¼	2850	1,1	1,5	7	30	2,9	(1)-(2)	25
GRIX 32-2/140 M-T	1" ¼	2850	1,4	1,9	9	35	3,5	(1)-(2)	27
APX 32-2/090 M-T	1" ¼	2850	0,9	1,2	5	25	2,1	(1)-(2)	20
APX 32-2/110 M-T	1" ¼	2850	1,1	1,5	7	30	2,9	(1)-(2)	25
APX 32-2/150 M-T	1" ¼	2850	1,4	1,9	9,9	32	3,5	(1)-(2)	27

1 = Cable H07RN8F 3x1 Ø 9 mm²

2 = Cable H07RN8F 4x1 Ø 10 mm²

3 = Cable H07RN8F 4x1.5 + 2x0.5 Ø 12 mm²

4. Overall dimensions

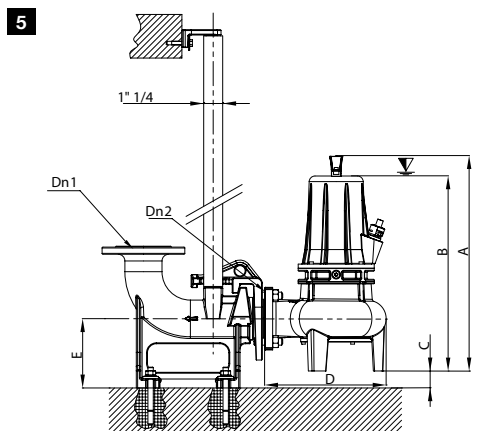
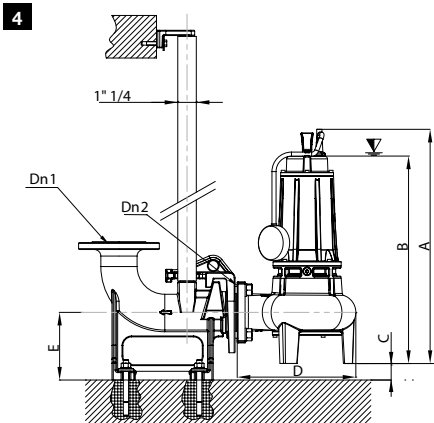
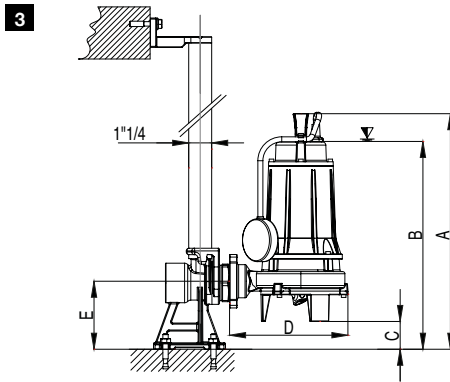
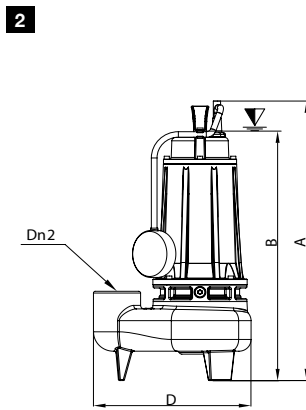
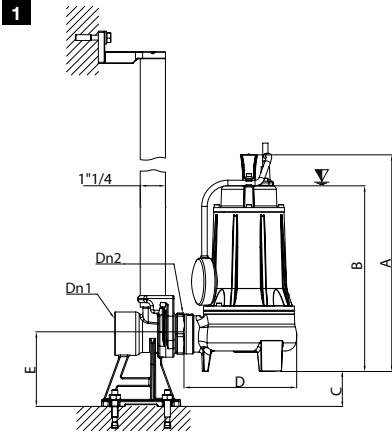

RIF.	TIPO	A	B	C	D	E	DN1	DN2
1	Compatta 1-1,5 M-T	307	254	-	202	-	-	G1" ¼
	Compatta 2-3 M-T	375	322	59	192	124	G1" ½	G1" ½
	Compatta 22 -32 M-T	400	347	38	225	124	G2"	G2"
	Compatta 4 - 55 M-T	444	391	38	226	124	G2"	G1" ½
1	Compatta EVO 2-3 M-T	395	342	59	225	124	G1" ½	G1" ½
	Compatta EVO 22-32 M-T	420	367	38	225	124	G2"	G2"
	Compatta EVO 4-55 M-T	464	411	38	226	124	G2"	G2"
2	Alpha V 2-3 M-T	381	329	-	232	-	-	G1" ½
	Alpha V 22-32 M-T	382	340	-	261	-	-	G2"
	Alpha V 4-55 M-T	439	386	-	238	-	-	G2"
2	Alpha V EVO 2-3 M-T	401	349	-	232	-	-	G1" ½
	Alpha V EVO 22-32 M-T	401	360	-	261	-	-	G2"
	Alpha V EVO 4-55 M-T	459	406	-	238	-	-	G2"
2	BIC 32-2/025-037 M-T	306	253	-	202	-	-	G1" ¼
	BIC 40-2/056-075 M-T	365	312	-	233	-	-	G1" ½
	BIC 50-2/075-110 M-T	402	349	-	266	-	-	G2"
2	BIC EVO 40-2/056-075 M-T	385	273		233	-	-	G1" ½
	BIC EVO 50-2/075-110 M-T	459	369		266	-	-	G2"
3	GRIX 32-2/090M-T	389	339	52	183	127	G2"	G1" ¼
	GRIX 32-2/110 M-T	425	374	52	189	127	G2"	G1" ¼
	GRIX 32-2/140 M-T	425	374	52	189	127	G2"	G1" ¼
3	APX 32-2/090 M-T	389	339	52	183	127	G2"	G1" ¼
	APX 32-2/110 M-T	425	374	52	189	127	G2"	G1" ¼
	APX 32-2/150 M-T	425	374	52	189	127	G2"	G1" ¼
4	DNA 50-2/110 M-T	502	430	30	268	131	G2"	DN50-G2
	DNA 50-2/150 M-T	502	430	30	268	131	G2"	DN50-G2
5	DNA 50-2/220 T	485	411	30	268	131	G2"	DN50-G2
	DNA 50-2/220-1 T	485	411	30	268	131	G2"	DN50-G2
	DNA 50-4/090 T	485	411	30	268	131	G2"	DN50-G2
4	DNA 65-2/110 M-T	536	474	38	270	155	DN 65	DN 65
	DNA 65-2/150 M-T	536	474	38	270	155	DN 65	DN 65
	DNA 65-2/220 T	520	436	38	270	155	DN 65	DN 65
4	DNB 65-2/080 M-T	460	419	45	235	155	DN 65	DN 65
	DNB 65-2/110 M-T	504	451	45	235	155	DN 65	DN 65
	DNB 65-2/150 M-T	504	451	45	235	155	DN 65	DN 65
5	DNA 65-2/220 (-1) (-2) T	456	412	45	246	155	DN 65	DN 65
5	DNA 80-2/110 M-T	548	506	46	290	185	DN 80	DN 80
	DNA - DNB 80-2/150 M-T	548	506	46	290	185	DN 80	DN 80
	DNA - DNB 80-2/220 (-1) T	513	467	46	290	185	DN 80	DN 80
	DNA - DNB 80-4/.. M-T	513	467	46	290	185	DN 80	DN 80

5. Installation

Safety rules

In order to protect yourself during the pump maintenance or installation, you should follow the following rules:

- A) It is very important that the installation is executed by qualified technicians;
- B) The appliance is not be used by person (including children) with reduced physical, sensory or mental capabilities, or lack of experiences and knowledge, unless they have been given supervision or instruction.
- C) Children being supervised not to play with appliance;
- D) Do not ignore the dangers for health and observe the sanitary measures;
- E) The staff working in pumping stations of dirty waters must be vaccinated against the possible illness which may be transmitted by wounds or only by contact or inhalation;
- F) In order to avoid contacts at the epidermis with infected liquids, you may wear suitable clothes and shoes, use also a safety belt, a rope, a helmet, safety glasses, if necessary a gas-mask;
- G) Do not ignore the danger of drowning. Do not work alone, even if the conditions are the best, we recommend the presence of another worker outside the tank;
- H) Provide to mark the area in which you are working by bars and other suitable signals, especially if it is a crossing area;
- I) Check the descent and ascent means efficiency and the possibilities of a fast return out at the air;
- L) Check that in the tank the oxygen is enough and test the absence of dangerous gases;
- M) Before effect any other intervention in the pumping station, pay attention that all the electric cables, present in the tank are switched off;
- N) Check there is not the risk of explosion danger before solding or before executed whatever kind of operation which may produces flames or sparks.
- O) These installation and operation instructions do not cancel or exclude the standard general rules do not specify in it. All the safety rules and general regulations of good technical paractice must be observed.

For a correct installation

The suction inlet of the pump must be placed in the lowest point of the tank. Pay attention the pump do not sink in the mud, it must be located on a base or suspended from the bottom. The electric equipement, set up outside the tank must be protected from all weathers and from whatever kind of gas coming from the tank.

Installation dimension for automatic working



This drawing represent the installation of a pump with automatic installation (with float). The float applied to a pump placed in a tank must have enough space to rise freely. It is recommended a non return ball valve in the delivery pipes, in order to stop whatever reflux.

6. Electrical connection

All the electrical connections must be executed by a qualified electrician.

The frequency and tension of the net must correspond to those indicated on the pump plate.

ATTENTION: Stop the power supply before opening the electropump. You can access the connection area, unscrewing the screws that connect the cover to the motor casing in the models Compatta *(EVO) , BIC *(EVO), Alpha-V *(EVO) , AM-AT, DNA e DNB ..2/110/150, while for DNA ..2/220, DNA - DNB 4 poles, and Grix, contact a specialized workshop.

- For the electrical connections, look them up in the schemes.
- In the threephase motors, check the rotation direction of the impeller (see the rotation direction section).
- Never force the pump to work without having found and corrected the cause of bad operation.
- In order to prevent water infiltrations in the pump, when you reassemble the cable, always use a new gasket (cable gland) and be sure that the cable entry gland is perfectly closed.

All the electrical connections must be protected against humidity and all joints must be absolutely watertight.

ELECTRICAL DRAWINGS

Connection
Singlephase 230V

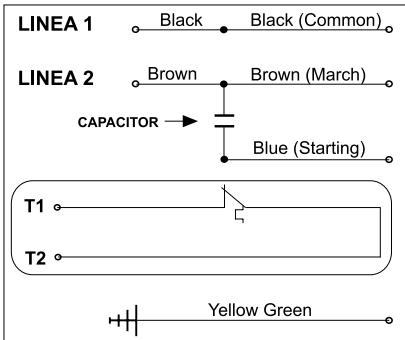

Connection
Threephase 230V / 400V

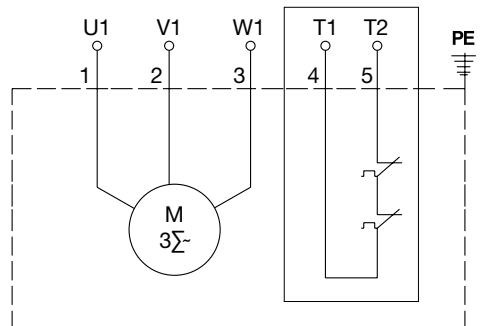

Motor Protection T1-T2

The models DNA ..2/220 (-1), DNA ..4/090, DNB ..2/220 (-1/-2), DNB 80-4/110 are equipped with thermal detectors T1-T2 in the winding (that must be connected to a control box equipped with suitable protection contacts), which promptly warn and stop the pump when the motor overheats. This safety device is normally closed and opens at a temperature of 130°C, thereby cutting out the pump from its power supply, and closes back only when the temperature reaches 75°C.

Rotation direction (only for threephase pumps)

After every new connection, loss of phase or tension, it is probable that the phases are inverted, so check the rotation direction. The wrong rotation direction causes the overheating of the motor, involves strong vibrations and considerably reduces the pump capacity. To check the right impeller rotation direction you have to tilt lightly the pump and start it.

ATTENTION: keep away from the impeller at the pump starting.

Pay attention at the starting kickback, that may be harmful.

If the pump gives you an anticlockwise (bird's-eye view) kickback when starting, the connection is right, otherwise stop the power supply and invert the two phases.

Seen from the suction inlet, the right impeller rotation is anticlockwise.

Starting Kickback

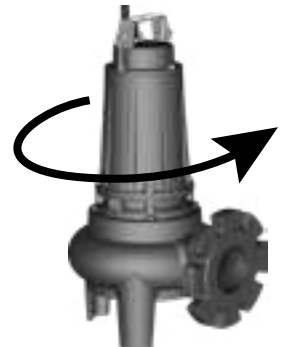

7. Operating rules

Transport

Do not lift the pump by the electric cable, use only the handle provided for the purpose. In case you have to move it from one place to another, for safety reasons we suggest to stop the power supply.

Below zero temperatures

While working or submerged in the liquid, the pump does not freeze. Removing the pump from the water and exposing it to below zero temperatures, the impeller may be blocked by the freeze. In case the impeller is blocked by the ice, you have to submerge the pump in the water and let the ice melt before starting. Avoid quick ways to defrost (for example to warm it) to avoid damages to the pump.

Cleaning

If the pump worked with liquid containing solid bodies, when it stops working, let it run a few minutes in clean water. Remove the impurities (mud, stones, etc..) to avoid them drying, blocking impeller and mechanical seal, stopping the pump from working.

Storage

In the case of pump storage:

- Store the pump in places protected from humidity and warm temperature.
- Place it in vertical position, paying attention to its stability just to avoid rollings and falls.

8. Inspection and maintenance

For your personal safety during a simple inspection

Before work on the pump, check the power supply is disconnected and the pump can not restart, not even accidentally. For personal cleanliness, be sure the pump has been carefully cleaned with water or specified products. If the pump is disassembled it is necessary to use working gloves.

Recommended advices

Periodical controls and maintenances are suggested to guarantee a safer future operating. If the pump is new or if the mechanical seals have been replaced, an inspection is recommended after the first week of working. The pump must be inspected after 2000 hours of working or at least once a year. Hard working conditions or occasional use require necessary frequent controls. A general check must be done on the following points:

- Check there are no infiltrations coming from the cable (in this case replace the cable gland, making sure that screws and bush are perfectly closed).
- If the supply cord is damaged, it must be replaced by the manufacturer, its service agent or similarly qualified persons in order to avoid any hazard.
- For the all the series with oil chamber, check the level and quantity of oil in the chamber (the charge of oil is complete when its level, with the pump laid on one side is of 1 -1,5 cm under the hole for the oil cap).

Motor insulation control

Once a year at least or after 4000 hours of working, check the insulation of the motor.

The measurement must be executed at the cable extremities (switch off from the panel) using a megohmmeter. The test tension is 1000V maximum in continuous tension.

The resistance of the winding towards the earth must be higher than 5 M Ω , otherwise it is necessary to execute two measurements, one for the cable and the other for the motor.

Take off the cable from the motor and execute the measurements of the winding towards the earth, connecting all the extremities of the winding.

- If the value of insulation of the cable is lower than 5 M Ω , it means the cable is damaged.
- If the motor has low insulation values, this means the winding is brokedown.

9. Spare Part List

The spareparts list and related purchases, are available on-line at **Dreno Part Selector** though our web site www.drenopompe.it, or contact us at info@drenopompe.it.

10. Impeller replacement

Series Compatta *(EVO), Alpha V *(EVO), BIC *(EVO), AM-AT, DNB 65

- A) *Turn the pump upside down while keeping the oil plug turned upwards.
- B) Remove the oil plug, and let the oil flow out of the tank.
- C) Unscrew the four screws that connect the motor casing to the body pump.
- D) Remove the body pump.
- E) Keeping the impeller blocked, unscrew the hexagonal head screw or the self locking nut, which connect it to the motor shaft.
- F) Unscrewing this screw or nut, you can easily remove the impeller. Before mounting a new impeller, pay attention that the terminal part of the shaft is clean and without imperfections.
- G) Assemble the body pump paying attention to put correctly the oring between the oil chamber plate and oil chamber flange.
- H) *Fill up the oil chamber, follow the operation on paragraph 11 (Oil Change).

*only for EVO versions.

Series DNA, DNB 80

- A) Unscrew the four screws that connect the motor casing to the body pump.
- B) Unscrew the four screws that connect body pump to closing plate and remove the closing plate.
- C) Keeping the impeller blocked, unscrew the hexagonal head screw or the self locking nut, which connect it to the motor shaft.
- D) Unscrewing this screw or nut, you can easily remove the impeller. Before mounting a new impeller, pay attention that the terminal part of the shaft is clean and without imperfections.

Series GRIX

- A) Unscrew the 4 screws that connect the pump body on the tripod.
- B) Remove the grider rotating part, unscrewing the screw inside.
- C) Remove the tripod support. C) Keeping the impeller blocked, unscrew the nut, which connect it to the motor shaft.
- D) Remove the impeller. Before mounting a new impeller, pay attention that the terminal part of the shaft is clean and without imperfections.

11. Oil Replacement

The oil used to refill the chamber of our electropumps is ecological, non toxic, tasteless and colourless. (Marcol 82 ESSO, Pharma 19, Q8 WF15 or equivalent product)

Change the oil:

- When at a simple inspection you find that it is mixed with other liquid
- At overhaul
- After 2000 hours of operation or in any case once a year.

To replace oil (where expected)

- A) Turn the pump upside down while keeping the oil plug turned upwards
- B) Unscrew the plug

Warning:

In case of seepage through the seal, the oil tank could be under pressure; be very careful and protect yourself from sprays. Take care not to endanger people or the environment when replacing oil, especially if the pump has worked with toxic fluids.

- C) Slowly turn the pump to let all the oil flow out of the tank (let it drip for a few minutes)
- D) Wash the chamber inside with washing oil.
- E) To refill oil, place the pump so that the plug is turned upwards
- F) Fill the chamber with non-toxic, tasteless and odourless paraffin oil. (Marcol 82, ESSO, Pharma 19 or similar).
- G) The chamber is full when the oil level is 20 mm below the oil plug thread.(see the section 9 for the exactly oil quantity.
- H) Before screwing back the screw plug, check the gasket and replace if required.

12. Mechanical seal replacement

12.1 Series Compatta, Alpha V, BIC, AM-AT

- A) Remove the impeller in according with the section 10 “ Impeller replacement”.
- B) Using two slot-headed screwdrivers, pull out the old seal, prising first on the revolving part, then on the fixed ring.
- C) Before mounting a new mechanical seal, check the seats are clean, without burrs or rulings, which may damage the mechanical seal or compromise the perfect seal on the shaft.
- D) Wet both parties of the mechanical seal with water-soap solution, to insert it easier.

ATTENTION: To push in seat the fixed ring, use a bush (having the same diameter of the shaft), to avoid jammings that can cause the broken of the fixed ring. Follow with the insertion of the rotating part.

- E) Now you can insert and fix the impeller and close the pump.

12.2 Series DNA, DNB, EVO versions

- A) Drain the oil chamber in according with the section 11 “Replace oil”.
- B) Remove the impeller in according with the section 10 “ Impeller replacement”.
Unscrew the four screws that connect the motor casing to the body pump.
- C) Keeping the pump on vertical place, remove the oring between the body pumps and the closing oil chamber cover.
- D) Remove the oil chamber cover
- E) Remove the mechanical seal rotation part
- F) Using two slot-headed screwdrivers, pull out the old seal, prising first on the revolving part, then on the fixed ring.
- G) Before fitting in a new seal, make sure the housings are clean, with no burrs or scorings which could damage the seal or in any case reduce the shaft sealing efficiency.
- H) Wet both parts of the seal with a mixture of soap and water to fit it easily.

WARNING: To push the fixed ring into its housing, use a bushing (same diameter as the shafting) to avoid any jamming which could damage the fixed ring. Then, fit in the revolving part.
Now, fit in and secure the impeller and close everything again.

- I) Fit the oil chamber flange with oring, and close the pump in according with the paragraph “Impeller replacement”
- J) Fill up the oil chamber, follow the operation on paragraph 11 (Oil Change)
- K) Now you can insert and fix the impeller and close the pump.

12.3 Series GRIX, APX

- A) Drain the oil chamber in according with the section 11 “Replace oil”.
- B) Remove the impeller in according with the section 10 “ Impeller replacement”.
- C) Unscrew the 4 screw that connect the body pump to motor casing and remove the body pump.
- D) Using two screwdrivers, remove mechanical seal rotation part
- E) Wet both parties of the mechanical seal with water-soap solution, to insert it easier.

ATTENTION: To push in seat the fixed ring, use a bush (having the same diameter of the shaft), to avoid jammings that can cause the broken of the fixed ring. Follow with the insertion of the rotating part.

- F) Now you can insert and fix the impeller and close the pump.

13. Tools

The tools necessary for a normal maintenance of the electropumps are the following:

- Allen screw keys of : 4, 5 and 6 mm
- Cross screwdriver
- 2 screwdrivers
- Hexagonal keys of: 8 and 17 mm

14. Troubles and remedies

The pump does not start:

- Loss of electric power supply (check if the fusibles have broken or a protection relay of the circuit intervened);
- The selection switch is turned OFF (turn ON);
- Loss of phase (check the connection);
- The impeller is blocked;
- Mechanical seal or ball bearing seized.

The pump does not stop:

- Failure to the stop regulator (clean or replace the stop regulator).
- The pump is not able to empty the tank till the stop level: there may be leaks in the installation; absence of the non return ball valve, to avoid the liquid reflow; necessity to replace the pump with another one of bigger capacity.

The pump works, but the delivery is scarce or inexistent:

- The pump works with a wrong rotating direction (this is possible only with threephase motors);
- Check the wear conditions of the hydraulic part, if necessary replace the parts;
- The pump is closed by an air-pocket (switch off the electropump and restart it after few minutes);
- The delivery pipe is obstructed, the non return ball- valves or the sluiceways are in part closed.

15. CE Conformity Declaration

The CE conformity declaration is available on our website: www.drenopompe.it, on the product pages.