

THE HISTORY OF RADIO AND RADIO CONTROL

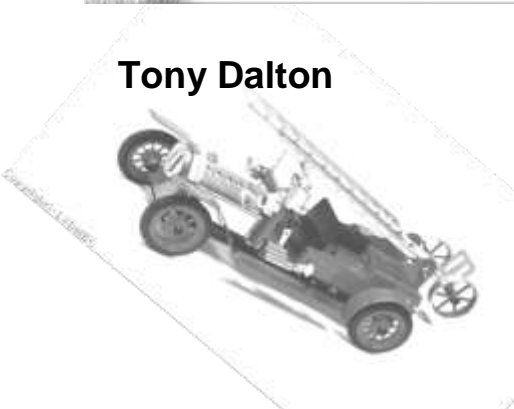

Tony Dalton



HISTORY OF RADIO AND RADIO CONTROL

Copyright © 2013 by The Luton and District Model Boat Club all rights reserved. No part of this article may be reproduced or transmitted in any form or by any means, electronic or mechanical, including photocopying and recording, or by any information retrieval system, without the prior permission in writing from the Secretary, Luton and District Model Boat Club

INDEX

PART 1 Discovery and Development

PART 2 Radio Frequency Spectrum

PART 3 Evolution of Radio Control

PART 4 Radio Control Systems

PART 5 Waveforms and Control



PART ONE

DISCOVERY AND DEVELOPMENT

HISTORY OF RADIO AND RADIO CONTROL

Have you ever wondered how radio was discovered and came into our ever day lives. We just accept Radio, Television and Radio Control of our models as if it has always been there.

Who discovered it? It is impossible to say where the story of radio actually began. Early scientists who saw and investigated the effects of electricity and magnetism are crucial to the story. This article traces the path of that story and highlights some of those scientists and inventors whose work contributed to creating modern day radio.

The first recorded significant reference is from an experiment carried out by Luigi Galvani (**Fig 1**), he was an Italian physician and physicist who had also studied medicine and had practiced as a doctor. In 1771, according to a popular version of the story, Galvani was slowly skinning a frog at a table where he had been conducting experiments with static electricity by rubbing the frog's skin. Galvani's assistant moved a scalpel (which had picked up a static charge) towards an exposed sciatic nerve of the frog. At that moment, they saw sparks, an electrical discharge - transmission had occurred and the dead frog's leg kicked as if alive. The observation made Galvani appreciate the relationship between electricity and animation. Galvani believed that the electricity came from the muscle. Galvani's associate Alessandro Volta (**Fig 2**), in opposition, reasoned that the animal electricity was a physical phenomenon caused by rubbing frog skin and not from the mussel. Volta's intuition was correct, Volta essentially objected to Galvani's conclusions about "animal electric fluid" but the two scientists disagreed respectfully and Volta coined the term "galvanism" for a direct current of electricity produced by chemical action. Thus, owing to an argument between the two in regard to the source or cause of the electricity, Volta built the first known battery in order to specifically disprove his associate's theory. Volta's "pile" became known therefore as a Voltaic Pile.



Fig 1 Luigi Galvani (1737 – 1798)



Fig 2 Alessandro Volta (1745 – 1827)

HISTORY OF RADIO AND RADIO CONTROL

James Clerk Maxwell (**Fig 3**) was a Scottish mathematician and theoretical physicist; around 1869 he proved mathematically the existence of electromagnetic (e/m) waves, whilst he was at Kings College London.

His most significant achievement was formulating a set of equations that became known as 'The Maxwell Equations'. They expressed the basic laws of electricity and magnetism in a unified fashion for the first time.

In 1871 he moved to Cambridge where he became the first Director of the Cavendish Research Laboratory (Cambridge University – Department of Physics).

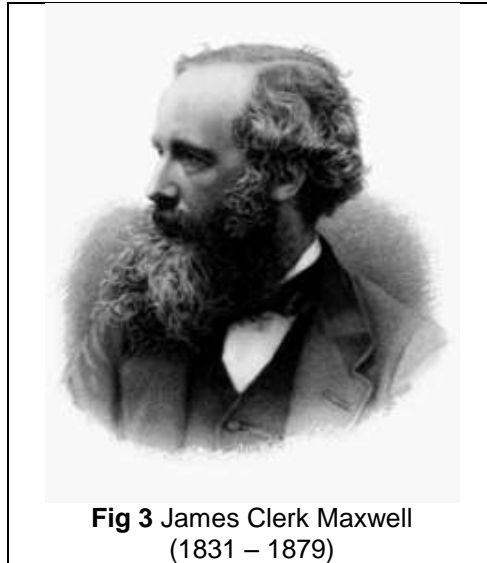

Heinrich Hertz (**Fig 4**) was a German physicist and in 1887 when he was barely 30 years old, he assembled some apparatus to prove Maxwell's theory that electricity travels through the "ether" in waves. To create the waves, he realised that a sudden discharge of electricity in the form of a spark across a gap between two wires would generate electromagnetic waves across his laboratory, he assembled a loop of wire, itself broken by a tiny gap. The loop, which was really the first aerial, received the waves which produced a feint spark across the gap. The apparatus that Hertz had created was the first transmitter and receiver.

The results of his experiments were published between 1888 and 1890. Hertz is credited with having discovered radio or Hertzian waves as they were first called.

He is known to have said '**I DO NOT THINK THE WIRLESS WAVE THAT I HAVE DISCOVERED WILL HAVE ANY PRATICAL APPLICATION**'

HISTORY OF RADIO AND RADIO CONTROL



The term wireless telegraphy is a historical term used today to apply to early radio telegraph communications techniques and practices, particularly those used during the first three decades of radio (1887 to 1920) before the term RADIO came into use.

The early radio signals were generated using either 'Spark Gap' (**Figs 5 & 6**) or 'Alternator' type transmitters.

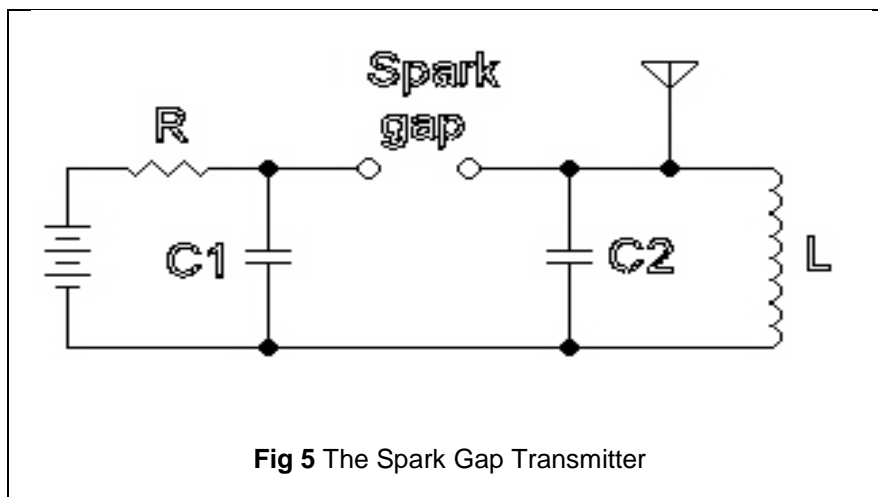

The Spark Gap Transmitter in its simplest form consists of a spark gap connected across an oscillatory circuit comprising a capacitor and an inductor. In a typical transmitter circuit, a direct current source charges a capacitor (C1) through resistor (R) until the spark discharges across the gap, then a pulse of current passes through the capacitor (C2). The function of the spark gap is to present initially a high resistance to the circuit to allow the capacitor to charge. When the breakdown voltage of the gap is reached, it then presents a low resistance to the circuit causing the capacitor to discharge. The discharge through the conducting spark takes the form of a damped oscillation, at a frequency determined by the resonant frequency of the circuit formed by L and C2.

HISTORY OF RADIO AND RADIO CONTROL



Fig 6 A Spark Gap Transmitter

The Radio Alternator (**Fig 7**) is an AC rotary voltage generator similar to a car alternator, when it is rotated it generates a high frequency AC signal. The one shown below is electrically driven and developed 50kW output and was used at the US Navy New Brunswick Radio station USA.

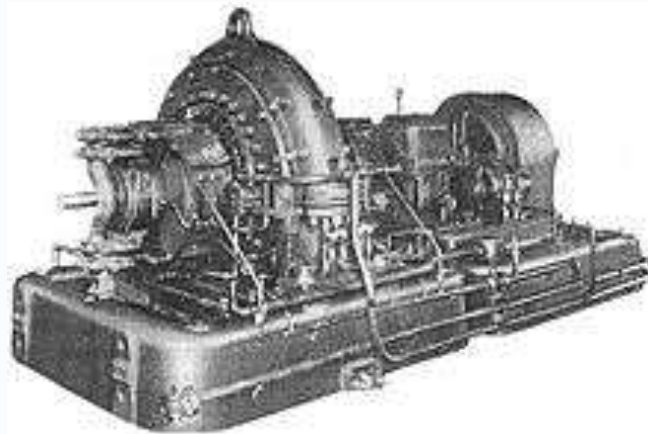

Fig 7 50kW High Frequency Alternator

Edouard Branly (**Fig 8**) was a physics professor at a Catholic University in Paris. In 1890 he invented the 'BRANLY COHERER (**Fig 9**)'. The coherer was a device used for detecting radio waves and took a number of years to develop. The earliest observations date back to around 1850.

He discovered that the resistance of a glass tube filled with metal filings fell to a few ohms if an electrical discharge occurred nearby, they were cohered. The filings could then be de-cohered by a sharp tap on the tube. They were effective in detecting spark gap transmissions. This as a method of signal detection was used up until about 1910.

HISTORY OF RADIO AND RADIO CONTROL

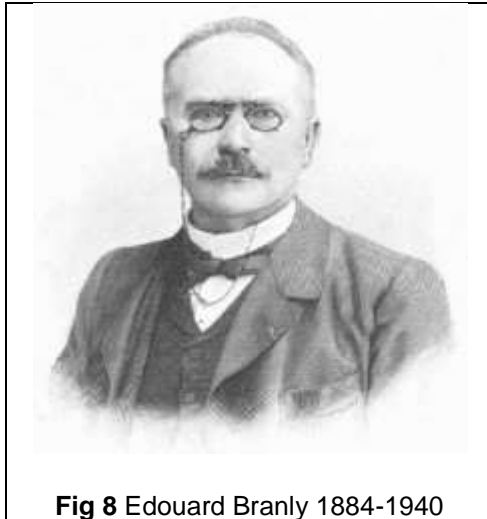

Fig 8 Edouard Branly 1884-1940



Fig 9 A Coherer

Guglielmo Marconi (**Fig 10**) was an Italian inventor. His Father was an Italian Gentleman and his Mother was Irish (Part of the Jamison family). In the autumn of 1894 Marconi performed his first experiments with radio waves in the attic of his parent's house in Bologna. Initially he was only able to achieve short distances of a few metres, but he made progress until he could send the signals over a distance of about 2 kilometres. Realising the possibilities of the system for maritime communications he gave a demonstration to the Italian authorities. Unfortunately they were not impressed, and as a result, Marconi moved to England.

Note: Marconi did not discover radio as we know of today, but developed a system of wireless telegraphy – sending messages by Morse code over radio waves

Marconi gave his first public demonstrations in December 1896 showing that radio waves could travel across water. There was considerable financial advantage in using radio to cross stretches of water as cables were expensive and very vulnerable. In the summer of 1897 Marconi set up a link spanning the 14 kilometres of the Bristol Channel and following this put on many other demonstrations and lectures. Marconi steadily increased the range of his wireless system. In the spring of 1899 a link was set up to cross the English Channel between an existing station at South Foreland in England and a station near Boulogne in France; it was also found that the signals from Boulogne could be received back at Marconi's factory in Chelmsford; **Fig 11** shows an early Marconi experimental transmitter.

In September of 1899, Marconi at 25 yrs old visited New York to report on the international yacht races off Sandy Hook. Two steam ships, fitted with Marconi equipment followed the yachts and sent messages to a nearby shore station.

HISTORY OF RADIO AND RADIO CONTROL



Fig 10 Guglielmo Marconi
1874 - 1937



Fig 11 Early Marconi
Experimental Transmitter

With the successes in using radio waves to cross the English Channel Marconi turned his eyes towards greater distances and being able to send messages across the Atlantic. He built an antenna at Poldhu and Newfoundland and the letter "S" was transmitted by the station in England that was received, although with great difficulty in Newfoundland on 12th December 1901.

A number of patents were taken out and disputed. When Marconi transmitted the signals across the Atlantic Tesla commented 'Marconi is a good fellow, let him continue, he is using 17 of my patents.

In 1904, the U.S. Patent office reversed its decision, awarding Marconi a patent for the invention of radio, possibly influenced by Marconi's financial backers in the States, who included Thomas Edison and Andrew Carnegie. This also allowed the U.S. government (among others) to avoid having to pay the royalties that were being claimed by Tesla for use of his patents. In 1907, Marconi established the first commercial transatlantic radio communications service, between Clifden, Ireland and Glace bay, Newfoundland.

Using various patents, the company called British Marconi was established and began communication between coast radio stations and ships at sea. This company along with its subsidiary American Marconi had a stranglehold on ship to shore communication. It operated much the way American Telephone and Telegraph operated until 1983, owning all of its equipment and refusing to communicate with non-Marconi equipped ships. Many inventions improved the quality of radio, and amateurs experimented with uses of radio, thus the first seeds of broadcasting were planted. In 1909, Marconi and Karl Ferdinand Braun were awarded the Nobel Prize in physics for "contributions to the development of wireless telegraphy".

HISTORY OF RADIO AND RADIO CONTROL

Reginald Fessenden (**Fig 12**) was a Canadian inventor and is well known for his early work in the radio field. In 1900 he built a radio system and managed to transmit a weak voice signal over the airwaves. In 1904 he was contracted with General Electric to design and build an Alternator to generate a frequency of 100,000Hz for radio transmission purposes.



Fig 12 Reginald Fessenden 1866-1932

Julio Cervera Baviera (**Fig 13**) developed radio in Spain around 1902. He obtained patents in England, Germany, Belgium, and Spain. In May–June 1899, Cervera had, with the blessing of the Spanish Army, visited Marconi's radiotelegraphic installations on the English Channel, and worked to develop his own system. He began collaborating with Marconi on resolving the problem of a wireless communication system, obtaining some patents by the end of 1899. Cervera, who had worked with Marconi and his assistant George Kemp in 1899, resolved the difficulties of wireless telegraph and obtained his first patents prior to the end of that year. On March 22, 1902, Cervera founded the Spanish Wireless Telegraph and Telephone Corporation and brought to his corporation the patents he had obtained in Spain, Belgium, Germany and England. He established the second and third regular radiotelegraph service in the history of the world in 1901 and 1902 by maintaining regular transmissions between Tarifa and Ceuta for three consecutive months, and between Javea (Cabo de la Nao) and Ibiza (Cabo Pelado). This is after Marconi established the radiotelegraphic service between the Isle of White and Bournemouth in 1898. In 1906, Domenico Mazzotto wrote: "In Spain the Minister of War has applied the system perfected by the commander of military engineering, Julio Cervera Baviera (English patent No. 20084 (1899)) Cervera thus achieved some success in this field, but his radiotelegraphic activities ceased suddenly, the reasons for which are unclear to this day.



Fig 13 Julio Cervera Baviera 1854 - 1929

HISTORY OF RADIO AND RADIO CONTROL

The company Telefunken was founded on May 27, 1903 as "Telefunken society for wireless telephon" of Siemens & Halske (S & H) and the Allgemeine Elektrizitäts-Gesellschaft (General Electric Company) as joint undertakings for radio engineering in Berlin. It continued as a joint venture of AEG and Siemens AG, until Siemens left in 1941. In 1911, Kaiser Wilhelm II sent Telefunken engineers to West Sayville, New York to erect three 600-foot (180-m) radio towers there. Nikola Tesla assisted in the construction. A similar station was erected in Nauen, creating the only wireless communication between North America and Europe

Ambrose Fleming (**Fig 14**) was an electrical engineer and physicist. At the age of 11 he had his own workshop where he built model boats and engines

Professor Fleming of University College London acted as a consultant to Marconi and he was very aware that detectors used in the receivers were the weak link in the receiving equipment of the day. Having seen the Edison effect - an effect Edison discovered when he was trying to extend the life of electric light bulbs, Fleming wondered whether this could be used to detect radio signals. In 1904 he gave details to his assistant who set up an experiment, it worked. The diode valve had been discovered. It consisted of a heated element in an evacuated glass bulb. A second element was also placed in the bulb but not heated. It was found that an electric current only flowed in one direction with electrons leaving the heated cathode and flowing towards the second element called the anode, and not in the other direction. The Diode Valve (**Fig 15**) had been invented.



Fig 14 Ambrose Fleming 1894-1945

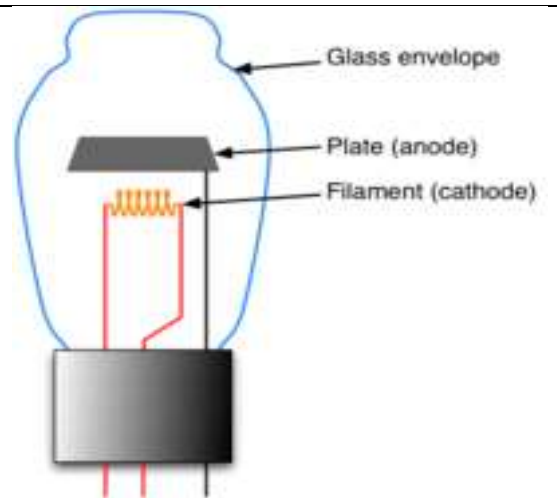

Fig 15 Diagram of a Diode Valve

Lee De Forest (**Fig 16**) was an American inventor; he went to Yale and studied mechanical and electrical engineering and obtained his Doctorate as well as a bachelor's degree. In 1906 he replicated Flemings diode and went a stage further by adding an additional element to create a device he called the Audion (**Fig 17**)

Although de Forest applied for several patents in the years between 1905 and 1907, the invention of the triode is normally taken to be 1906. Initially the triode was only used as a detector. Its operation was not understood, and this prevented its full potential from being utilised.

HISTORY OF RADIO AND RADIO CONTROL

It took some time before the full potential of the triode was realised. Eventually it was de Forest who succeeded in using it as an amplifier and in 1912 he built an amplifier using two devices. This was demonstrated to AT&T who understood its potential for use as a repeater in long distance telephone circuits.

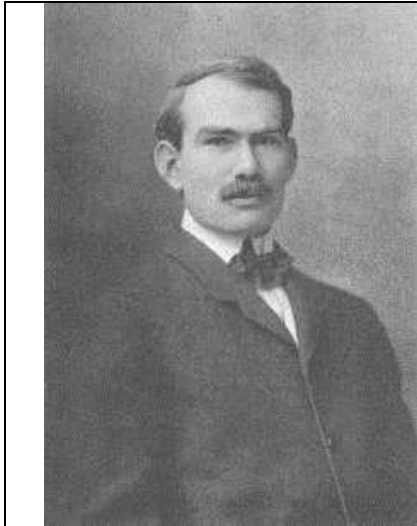

Fig 16 Lee DeForest 1873-1961



Fig 17 The DeForest Audion

The invention of amplitude-modulated (AM) radio, so that more than one station can send signals (as opposed to spark-gap radio, where one transmitter covers the entire bandwidth of the spectrum) is attributed to Reginald Fessenden and Lee De-Forrest. On Christmas Eve 1906, Reginald Fessenden used an Alexanderson alternator and rotary spark gap transmitter to make the first radio audio broadcast, from Brant Rock, Massachusetts. Ships at sea heard a broadcast that included Fessenden playing O' Holy Night on the violin and reading a passage from the Bible.

In April 1909 Charles David Herrold an electronics instructor in San Jose California constructed a broadcasting station. It used spark gap technology, but modulated the carrier frequency with the human voice, and later music. The station "San Jose Calling" (there were no call letters), continued to eventually become today's KCBS in San Francisco. Herrold, the son of a Santa Clara Valley farmer, coined the terms "narrowcasting" and "broadcasting", respectively to identify transmissions destined for a single receiver such as that on board a ship, and those transmissions destined for a general audience. (The term "broadcasting" had been used in farming to define the tossing of seed in all directions.) Charles Herrold did not claim to be the first to transmit the human voice, but he claimed to be the first to conduct "broadcasting". To help the radio signal to spread in all directions, he designed some omnidirectional antennas, which he mounted on the rooftops of various buildings in San Jose. Herrold also claims to be the first broadcaster to accept advertising (he exchanged publicity for a local record store for records to play on his station).

HISTORY OF RADIO AND RADIO CONTROL

Edwin Armstrong (**Fig 18**) was an American electrical engineer and an inventor.

Although thermionic valves enabled far greater performance to be gained in radio receivers, the performance of the devices was still very poor and receivers of the day suffered from insensitivity and poor selectivity. During the First World War a considerable amount of effort was devoted into resolving these problems.

In 1918, Armstrong developed a receiver where the incoming signal was converted down to a fixed intermediate frequency. Here it could be satisfactorily amplified and filtered. Unfortunately the idea did not gain much acceptance at first because the war ended, and superhet receivers were very expensive because of the numbers of valves they used. It took until the late 1920s before the number of transmitting stations rose to a level that the performance of the superhet was required and further developments meant they could be made more cheaply.

The full name is '**Supersonic Heterodyne Receiver**' - Heterodyne means the mixing of two frequencies' The Intermediate frequency being 455kHz for single conversion AM receivers.



Fig 18 Edwin Armstrong 1890-1954

Edwin Armstrong is credited with developing many of the features of radio as it is known today. Armstrong patented three important inventions that made today's radio possible. Regeneration, the superheterodyne circuit and wide-band frequency modulation or FM. Regeneration or the use of positive feedback greatly increased the amplitude of received radio signals to the point where they could be heard without headphones. The superhet simplified radio receivers by doing away with the need for several tuning controls. It made radios more sensitive and selective as well. FM gave listeners a static-free experience with better sound quality and fidelity than AM.

HISTORY OF RADIO AND RADIO CONTROL

There was considerable distrust between Lee de forest and Edwin Armstrong that led to numerous bitter patent suites. De forest successfully sued Armstrong for patent infringements (the radio industry has generally believed that Armstrong was in the right). Litigation with RCA and other companies over patent rights left Armstrong in debt, ruined his marriage and destroyed his health. He committed suicide in 1954.

The possibilities of broadcasting entertainment and news using radio soon arose. In Britain initial transmissions were made by the Marconi Company from their Chelmsford works for experimental purposes. These broadcasts started in February 1920. Although only two daily programmes were broadcast, however they had an enormous impact. The famous international singer Dame Nellie Melba took part in one on 20th June 1920.

Long distance communications had until now been concentrated on the long wavelengths accordingly radio amateurs had been only allowed to use the short wave bands, which were thought to be of little commercial value. However in the USA a number of amateur stations had made contacts over considerable distances. This made people wonder whether it would be possible to make contact across the Atlantic. After several sets of tests commencing in 1921 contact was finally made between the American stations 1MO, 1XAM and the French station 8AB in November 1923.

In 1912, the RMS Titanic sank in the northern Atlantic Ocean. After this, wireless telegraphy using spark-gap transmitters quickly became universal on large ships. In 1913, the International Convention for the Safety of Life at Sea was convened and produced a treaty requiring shipboard radio stations to be manned 24 hours a day. A typical high-power spark gap was a rotating commutator with six to twelve contacts per wheel, nine inches (229 mm) to a foot wide, driven by about 2,000 volts DC. As the gaps made and broke contact, the radio wave was audible as a tone in a magnetic detector at a remote location. The telegraph key often directly made and broke the 2,000 volt supply. One side of the spark gap was directly connected to the antenna. Receivers with thermionic valves became commonplace before spark-gap transmitters were replaced by continuous wave transmitters.

On March 8, 1916, Harold Power with his radio company American Radio and Research Company (AMRAD) broadcast the first continuous broadcast in the world from Tufts University under the call sign 1XE (it lasted 3 hours). The company later became the first to broadcast on a daily schedule, and the first to broadcast radio dance programs, university professor lectures, the weather, and bedtime stories.

In the 1920s, a United States government publication, "*Construction and Operation of a Simple Homemade Radio Receiving Outfit*", showed how almost any person handy with simple tools could a build an effective crystal radio receiver.

The most common type of receiver before vacuum tubes was the crystal set (**Fig 19**); although some early radios used some type of amplification through electric current or battery. Inventions of the triode amplifier, motor generator, and detector enabled audio radio. The use of amplitude modulation (AM), with which more than one station can simultaneously send signals (as opposed to spark-gap radio, where

HISTORY OF RADIO AND RADIO CONTROL

one transmitter covers the entire bandwidth of spectra) was pioneered by Fessenden and Lee de Forest.

To this day there are a small but avid base of fans of this technology who study and practice the art and science by designing and making crystal sets as a hobby; the Boy Scouts of America have often undertaken such craft projects to introduce boys to electronics and radio, and quite a number of them having grown up remain staunch fans of a radio that 'runs on nothing, forever'. As the only energy available is that gathered by the antenna system, there are inherent limitations on how much sound even an ideal set could produce, but with only moderately decent antenna systems remarkable performance is possible with a superior set.

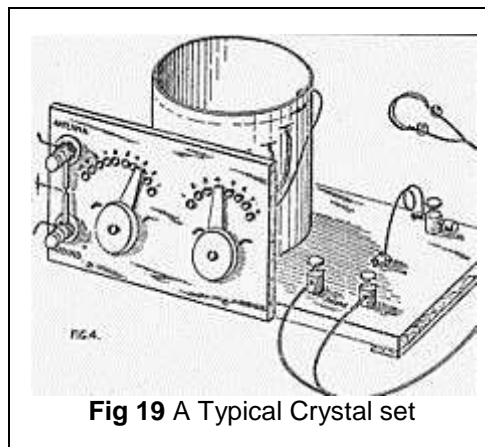

Fig 19 A Typical Crystal set

In October of 1924 a station at Mill Hill School in the North of London made contact with one in Dunedin New Zealand on the opposite side of the globe.

Meanwhile commercial interests were also exploring the capabilities of the short wave bands, and a number of links were set up.

In May 1922 the Marconi Company was allowed to set up a broadcast station in London. Later in the year the British Broadcasting Company was formed and this took over the station that had the famous call sign 2LO.

The Westinghouse Company set up a short wave broadcasting station (KDKA) in East Pittsburgh, which transmitted on a wavelength of 62.7 metres; this was successfully received and rebroadcast in Britain.

In Britain the amateur station 2NM run by Gerald Marcuse started broadcasts in 1927. These gained great popularity and shortly after their start the BBC commenced broadcasting.

However it took until 1932 before the Empire service (the forerunner of the BBC World Service) was officially opened, broadcasting from Daventry in the Midlands.

Although wideband FM is widely used today, it took many years for its advantages to be accepted; previously everyone had tried to improve its performance by reducing the bandwidth.

HISTORY OF RADIO AND RADIO CONTROL

It was Edwin Armstrong who we spoke about earlier that made the breakthrough, however it took many years for him to convince people about its superiority. In 1934 he brought his idea to the attention of RCA, and a year later he set up a demonstration. In 1939 he used his own money to finance a station to prove that the system worked. Shortly after this the idea began to take off and by January 1940, 150 applications for FM broadcast stations had been submitted in the USA. In 1954 the BBC launched its wideband FM service.

Arthur C Clarke (**Fig 20**) was a British author and inventor and most famous for his science fiction novel '2001 a Space Odyssey'.

Up until this time all international communications relied on either short wave radio transmissions or cable links. Short wave radio was unreliable and subject to high levels of interference, and international telephone cables were exceedingly expensive.

Arthur C Clarke wrote a historic article in Wireless World describing a system that used satellites in geostationary orbit. Signals would be transmitted up to the satellite that would rebroadcast them back to the earth. In view of their altitude above the earth the signals would be able to be received many thousands of miles away from the original transmitting station. Clarke calculated that only three satellites would be required to cover around the globe. His idea was revolutionary, and it took many years before the technology was available for it to be implemented.

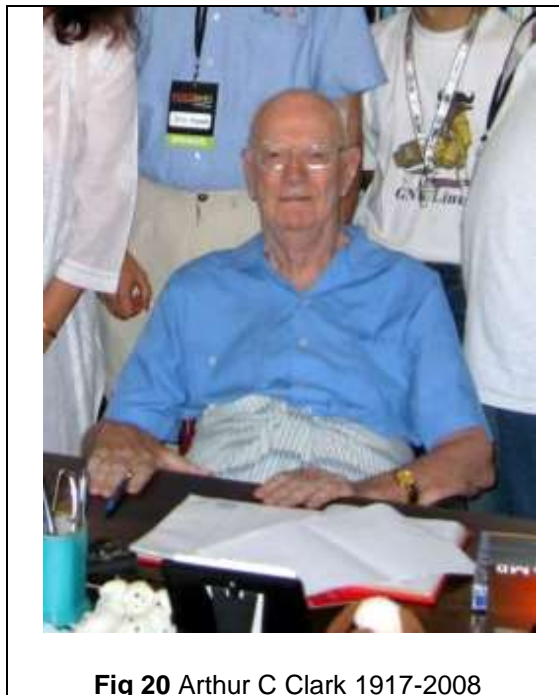

Fig 20 Arthur C Clark 1917-2008

On 4th October 1957 the USSR (Russia) launched the first satellite into orbit Sputnik (**Fig 21**). The satellite was in a very low orbit, which took 96 minutes to circle the earth. It only transmitted a bleep, but it was sufficient to prove that satellites could be successfully put into orbit.

HISTORY OF RADIO AND RADIO CONTROL

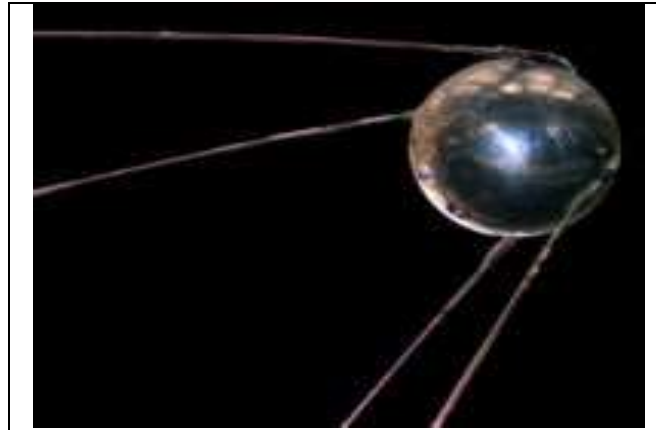

Fig 21 1957 Sputnik 1 Launched

Several other satellites followed Sputnik. Some were launched by the Soviet Union, others by the Americans, However the launch of Telstar (**Fig 22**) proved to be a major milestone in satellite development. On 23rd July 1962 it was used to make the first live transatlantic television transmissions. Signals from the USA were seen live in many homes around Europe, making communication history.

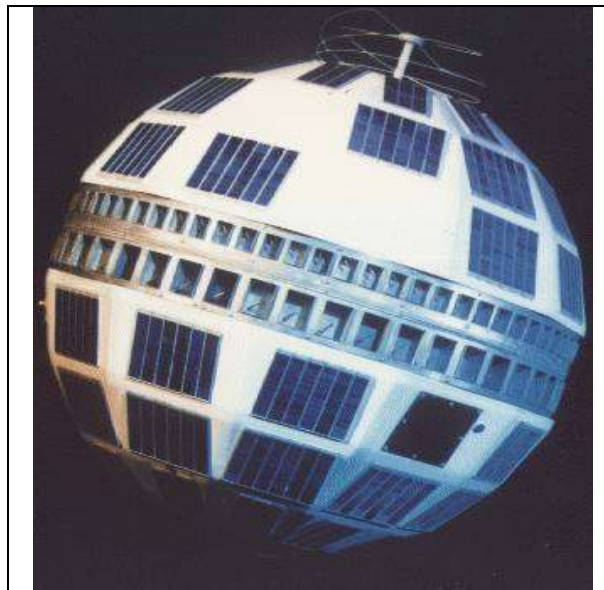
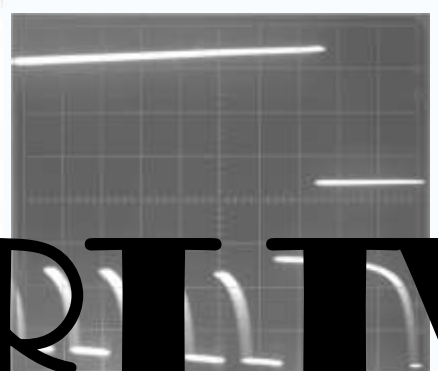
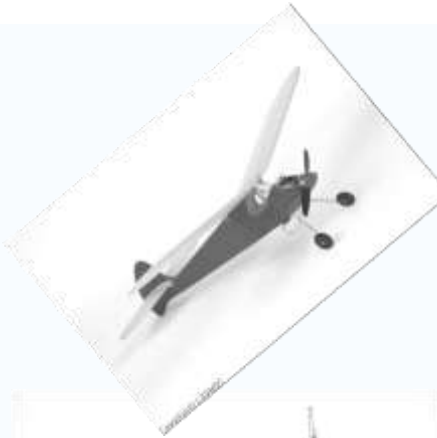

Fig 22 Telstar

Another satellite named Relay was used to beam the pictures of the funeral of the Late President Kennedy to people all over the world. Since then the number of satellites have considerably increased, along with improvements in technology.

Now most international communications are routed via satellites. Apart from this they provide many other useful functions including navigation, geological surveys, weather information, television broadcasting etc.



PART TWO

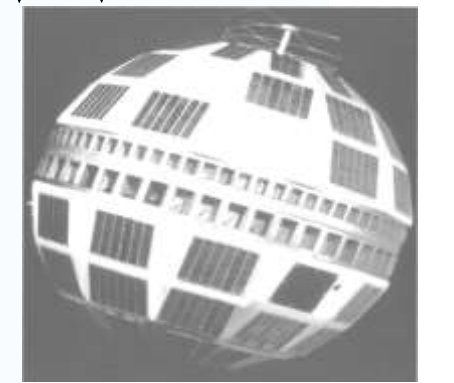
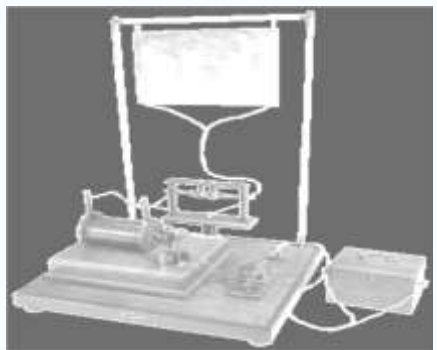

RADIO FREQUENCY SPECTRUM

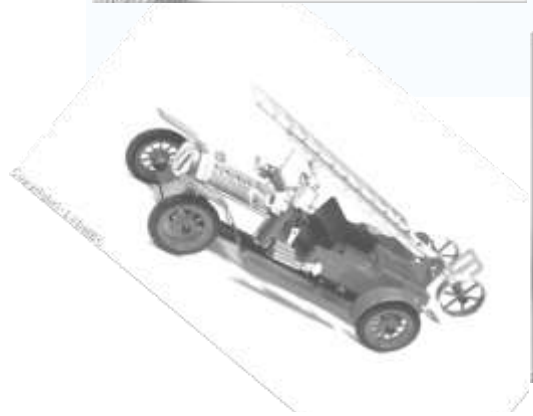

HISTORY OF RADIO AND RADIO CONTROL

Radio Waves travel through the atmosphere at the same speed as light which is approximately:

300,000,000 metres per second or 671,000,000 MPH

That is 1ft per Nanosecond (As defined on the 21st October 1983)

It takes 0.1336 seconds for a radio wave to travel around the world.

It took Houston Ground Control nearly 3 seconds to communicate with Apollo 8 when it was orbiting the moon.

There are three ways in which radio waves are propagated (transmitted) through the atmosphere and these are **SKY WAVES**, **GROUND WAVES** and **SPACE WAVES**

The diagram (**Fig 23**) below shows how these different methods of transmission are used

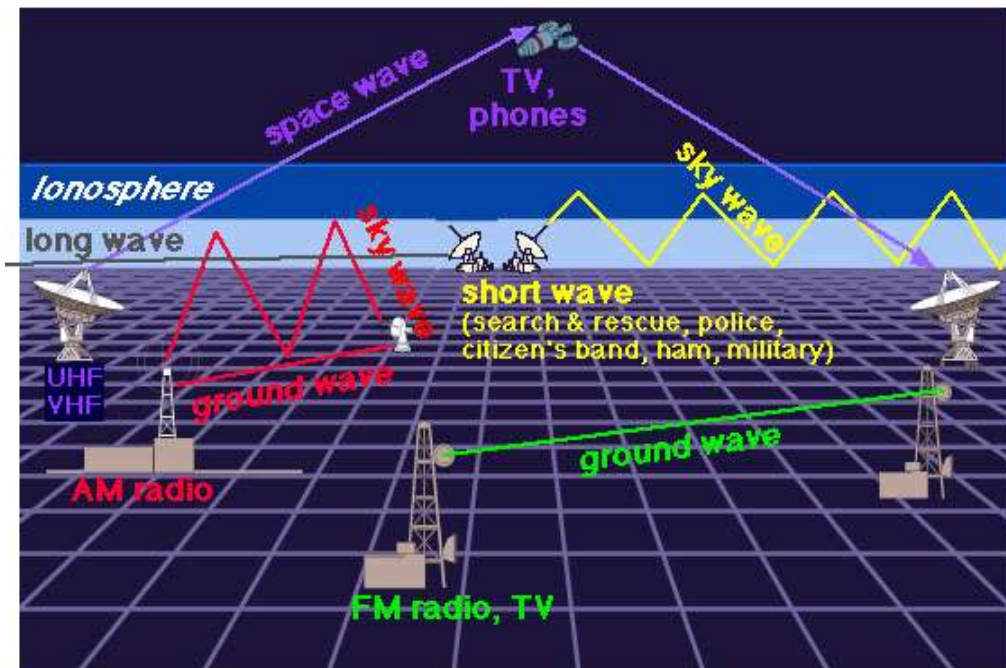

Fig 23 Methods of Radio Frequency Transmission

Some Radio transmissions are reflected off the ionisation layers that surround the earth

The D layer creates the ground wave effect and the F layer creates the skywave effect.

Sky Waves are reflected off the Ionosphere which is also known as the Appleton layer (Named after Sir Edward Appleton who was knighted in 1941 for his work and received a Nobel Prize in 1947). This is some 120 to 400km above the earth's surface.

The following diagram (**Fig 24**) shows where the different layers are located above the earth's atmosphere.

HISTORY OF RADIO AND RADIO CONTROL

OUTER SPACE

F Layer 120 to 400km (Appleton Layer)

E Layer 90 to 120km

D Layer 50 to 90km

Earth's Surface

Fig 24 Ionisation Layers

Long Wave radio broadcasting band are frequencies between 153 - 279 kHz, which correspond to wavelengths longer than 600 metres. Long wave signals have the property of following the curvature of the earth, making them ideal for continuous, continental communications.

Unlike shortwave radio, long wave signals do not reflect or refract using the ionosphere, so there are fewer interference-caused fadeouts. Instead, the D-layer of the ionosphere and the surface of the earth serve as a waveguide directing the signal.

The earliest radio transmitters were all long wave transmitters, because propagation of radio waves of higher frequency was not yet understood. Spark-gap transmitters or Radio alternators were commonly used to generate the radio frequency carrier wave.

Medium Wave (MW) radio transmissions serve as the most common band for broadcasting. The standard AM broadcast band is 525 kHz to 1615 kHz in Europe, but is up to 1715 kHz in USA.

Medium wave signals have the property of following the curvature of the earth (the ground wave) at all times, and also reflecting off the ionosphere at night (Sky Wave). This makes this frequency band ideal for both local and continental-wide service, depending on the time of day.

It is interesting to note that many North American stations are required to shut down or reduce power at night in order to make way for clear channel stations that can then be received over a wider range. Due to the high demand for frequencies in Europe, many countries operate single frequency networks; in Britain, BBC Radio 5 broadcasts from various transmitters on either 693 or 909 kHz. These transmitters are carefully synchronised to minimise interference from more distant transmitters on the same frequency.

Shortwave radio (HF) (Sky Waves) operate between the frequencies of 2,310 kHz and 30MHz (30,000 kHz) and came to be referred to as such in the early days of radio because the wavelengths associated with this frequency range were shorter than those commonly in use at that time. An alternate name is HF or high frequency radio. Short wavelengths are associated with high frequencies because there is an inverse relationship between frequency and wavelength.

HISTORY OF RADIO AND RADIO CONTROL

Very High Frequency (VHF) are frequencies in the range of 30MHz (100cm) to 300MHz (10cm) and is used for Radio, TV, and General Voice Communication and of course Radio control.

Microwave are frequencies in the range of 300MHz (10cm) to 300GHz (1mm) However, the boundaries between far infrared, light, Terahertz radiation, microwaves, and ultra-high-frequency radio waves are fairly arbitrary and are used variously between different fields of study.

The microwave range includes ultra-high frequency (UHF) (0.3-3 GHz), super high frequency (SHF) (3-30 GHz), and extremely high frequency (EHF) (30-300 GHz). The existence of electromagnetic waves, of which microwaves are part of the higher frequency spectrum, was predicted by James Clerk Maxwell from his famous Maxwell's equations.

In 1888, Heinrich Hertz was the first to demonstrate the existence of electromagnetic waves by building an apparatus that produced and detected microwaves in the UHF region. The design necessarily used knife and fork type materials, including a horse trough, a wrought iron point spark, Leyden jars, and a length of zinc gutter whose parabolic cross-section worked.

Above 300 GHz, the absorption of electromagnetic radiation by Earth's atmosphere is so great that it is effectively opaque, until the atmosphere becomes transparent again in the so-called infrared and optical window frequency ranges.

The following diagram (**Fig 25**) shows the opacity of the earth's atmosphere and how it effects radio wave transmission.

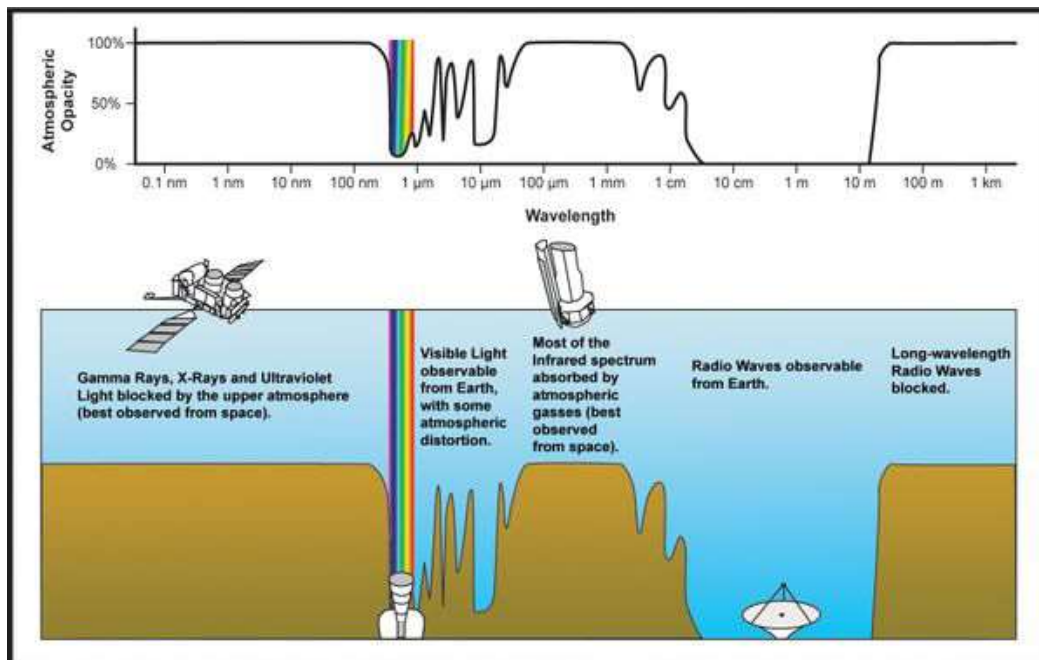
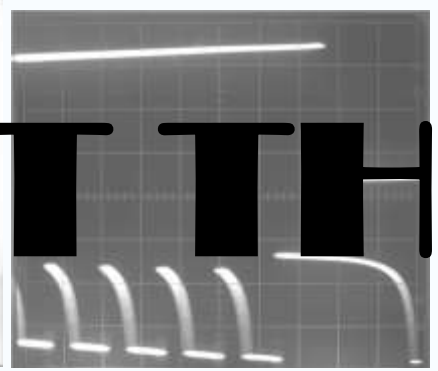
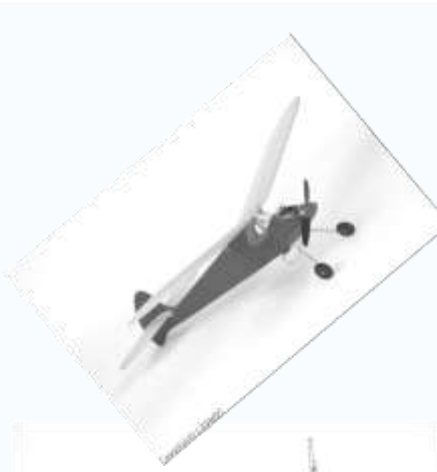

Fig 25 Opacity of the earth's atmosphere

END OF PART 2

HISTORY OF RADIO AND RADIO CONTROL



PART THREE



**THE EVOLUTION OF
RADIO CONTROL**

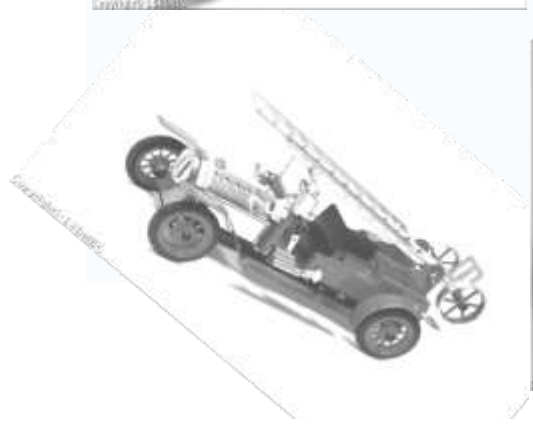

HISTORY OF RADIO AND RADIO CONTROL

The possibility of Radio Remote Control was appreciated almost as soon as the first demonstrations of radio itself.

Patrick Alexander (**Fig 26**) was a British aeronautical pioneer, fascinated by the prospect of heavier-than-air flight, an enthusiastic balloonist and was also particularly active in metrology.

The credit for the first person to suggest radio control of an aircraft may belong to Patrick as early as 1888.

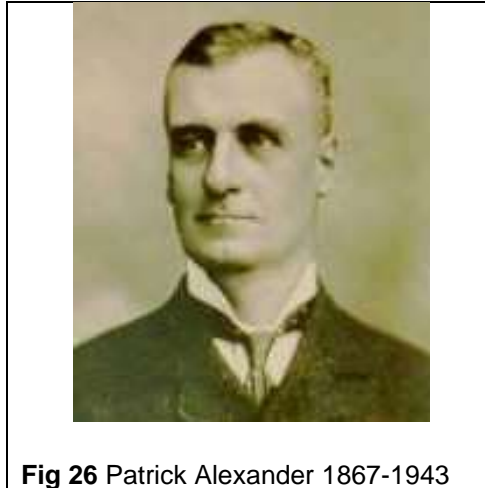

Nikola Tesla (**Fig 27**) was a Serb-American, physicist, inventor and engineer who suffered from obsessive-compulsive disorder – doing things in groups of three.

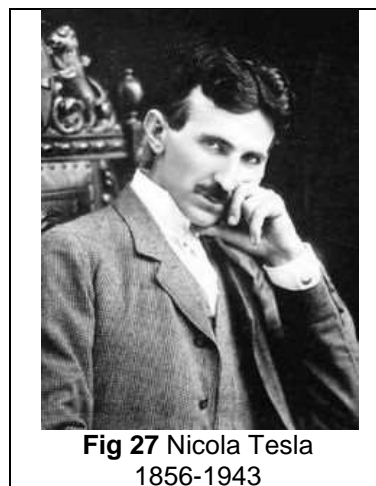

He demonstrated a small boat (**Fig 28**) and an Airship (**Fig 29**) which could obey commands by sending frequencies to tuned circuits within the models, he was granted a US patent on this invention on November 8th, 1898.

Tesla prophesied a future in which telautomatons (robots) did man's bidding, perhaps some-day exceeding mankind

HISTORY OF RADIO AND RADIO CONTROL

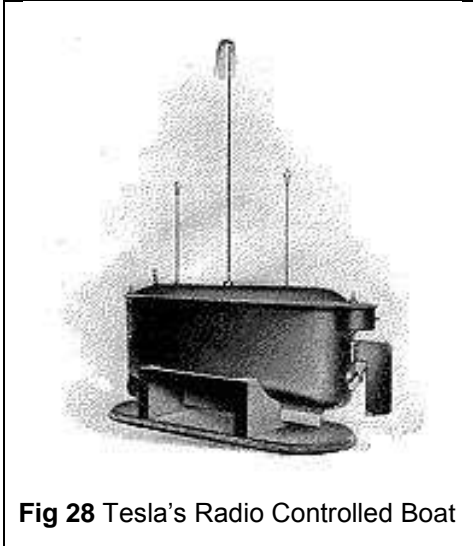

Fig 28 Tesla's Radio Controlled Boat

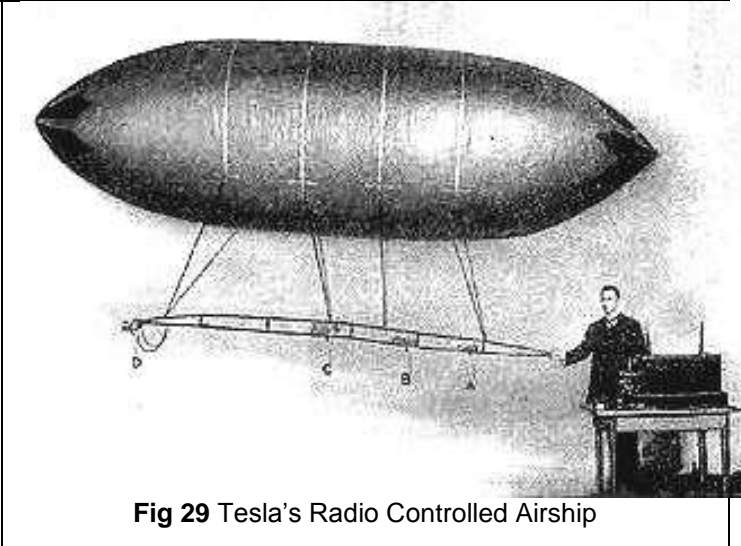

Fig 29 Tesla's Radio Controlled Airship

Jack Kitchen was an inventor from Lancashire. In 1904 he built and installed an experimental radio control system into a Steam Launch called 'BAT' (**Fig 30**) on Lake Windermere. There is also a reference to him designing a Radio Controlled torpedo at the same time.



Fig 30 'Bat' Steam Launch 1904

In 1909 a Mr M Gabet designed a radio controlled torpedo 'Torpille Radio - Automatique' (**Fig 31**) as can be seen below assembled on the slipway.

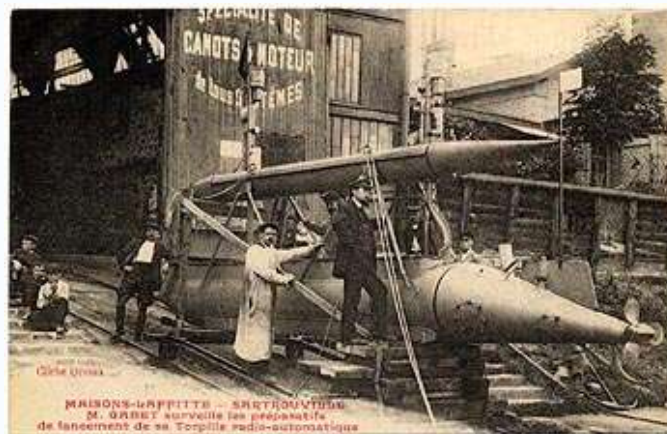

Fig 31 Torpille Radio Automatique

HISTORY OF RADIO AND RADIO CONTROL

In the 1920s, various radio-controlled ships were used for naval artillery target practice. In 1922, the obsolete US Navy battleship USS Iowa became the first of these target ships to have radio control gear installed. It was developed by the radio engineer John Hays Hammond, Jr. and was installed prior to her sinking during a gunnery practice exercise in March 1923.

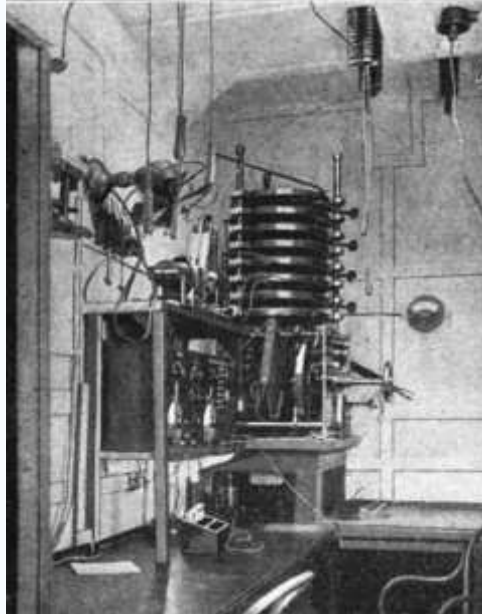

Fig 32 RC Equipment in USS IOWA

The picture in (**Fig 32**) shows the Radio Control Equipment installed inside the Deckhouse of the Battle ship IOWA when without any crew aboard it is steered and controlled by another ship some distance away.

Archibald Low (**Fig 33**) was an English engineer, research physicist and inventor. He was author of more than 40 books. Low has been called 'The father of radio guidance systems' due to his pioneering work on guided rockets, planes and torpedoes. In 1917 as head of the RFC Experimental Works, he was the first person to use radio control successfully on an aircraft.



Fig 33 Archibald Low 1888-1956

HISTORY OF RADIO AND RADIO CONTROL

It is interesting to note that in 1929 a radio 'expert' wrote in a model publication that Radio Control of models would not be possible due to the size of the equipment.

In the 1920s, various radio-controlled ships were used for naval artillery target practice.

The Soviet Red Army used remotely controlled tanks (teletanks) during the 1930's in the 'Winter War' and the early stages of World War II.

A teletank is controlled by radio from a control tank at a distance of between 500 to 1500 meters, the two constituting a tele-mechanical group.

Probably the first really successful R/C aircraft was the DeHaviland Tiger Moth II DH82B of which there were 380 built.

It had a simple R/C system and was known as the 'Queen Bee' (**Fig 34**).

A subsequent purpose built drone ordered by the MOD and known as the 'Queen Wasp' was built by Airspeed Ltd of Portsmouth.



At about the same time a Major Raymond Phillips was touring the UK giving displays with his electric powered airship, it used a spark transmission system and a method of sequential controls.

Reginald Denny (**Fig 35**) was an English screen actor and modeller; his acting took him to the USA in 1912. He opened a model shop on Hollywood Boulevard in 1934 and later formed a Company called Reginald Denny Industries. He also produced a nine-foot R/C model which he tried to sell to the Army for target practice for AA gunners, It crashed on a demo flight.

HISTORY OF RADIO AND RADIO CONTROL

A later version OQ-2A with 5 (tone) channels worked well and went into production. His plant was named Radioplane Inc. One of his model planes is shown in **Fig 36**.



Fig 35 Reginald Denny 1891-1967



Fig 36 One of Denny's RC Aeroplanes

An army photographer, David Conover spotted a young lady named Norma Jeane Baker (**Fig 37**) on the wing assembly plant; she later changed her name to Marilyn Monroe.



Fig 37 Norma Jeane Baker

Ross Hull (**Fig 38**) was born in Melbourne 1902, and built successful RC models from 1914 onwards. He died from electrocution in Connecticut, USA 1938 while experimenting with early TV broadcasting. In the modelling world he was a radio control pioneer credited in 1938 for having invented the rubber driven escapement. In 1936 and 1937 he flew the world's first successful R/C sailplane.

Ross Hull is also known for his pioneering work in the field of development in the VHF and UHF spectrum, in particular equipment for the 56 MHz amateur band and later for the 112 and 224 MHz amateur bands. These were the bands offered to the

HISTORY OF RADIO AND RADIO CONTROL

amateurs during the period between World War I and World War II. Initially they were shunned by the professionals due to their perceived "line-of-sight" limitations.



Fig 38 Ross Hull 1902-1938

In 1937 Radio Control was introduced as an event at the US Nationals and was won by Chester Lanzo (**Fig 39**) though Chester confided that there was more radio than control as vibration from the engine caused problems with the Coherer detector.



Fig 39 Chester Lanzo 1914 - 1989

In 1938, the Good brothers Bill and Walt entered the US Nationals and won, though the stabilizer got knocked out of alignment on take-off resulting in the control not being too great. The following year they got it all together and won again. The 1938 plane can be seen in the Aerospace Section of the Smithsonian Institute.

Development of the motor car mainly in the USA with respect to car radios using miniature valves running on low dc voltage gave rise to further Radio Control development.

The picture (**Fig 40**) shows a Valve Radio Receiver manufactured by Triang for one of their many toy boats that were made during the 50's.

HISTORY OF RADIO AND RADIO CONTROL



Radio control was further developed during World War II, primarily by the Germans who used it in a number of missile projects one of which was called Fritz-X. Their main effort was the development of radio-controlled missiles and glide bombs for use against shipping, a target that is otherwise both difficult and dangerous to attack.

However by the end of the war the Luftwaffe was having similar problems attacking allied bombers, and developed a number of radio-controlled anti-aircraft missiles, none of which saw service. The effectiveness of the Luftwaffe systems was greatly reduced by British efforts to jam their radio signals. After initial overwhelming successes, the British launched a number of commando raids to collect the missile radio sets. Jammers were then installed on British ships, and the weapons basically "stopped working".

The German development teams then turned to wire guidance once they realized what was going on, but these systems were not ready for deployment until the war had already moved to France.

Both the British and USA also developed radio control systems for similar tasks, in order to avoid the huge anti-aircraft batteries set up around German targets. However none of these systems proved usable in practice, and the one major US effort, Project Aphrodite, proved to be far more dangerous to its users than to the target.

Radio control systems of this era were generally mechanical in nature. A small radio receiver was placed in the missile; the signal from the controller (transmitter) was "played" into a small speaker.

In front of the speaker were a number of small metal "fingers" with different resonant frequencies, each one tuned to vibrate when a particular tone was played in the speaker (a so called - reed relay). The vibration would push on electrical contacts connected to the actuators of the control surfaces of the missile.

HISTORY OF RADIO AND RADIO CONTROL

The controller's radio transmitter would play the different frequencies in response to the movements of a control stick. These systems were widely used until the 1960s, when the increasing use of solid state systems greatly simplified radio control.

The mechanical resonant systems using reed relays were replaced by similar electronic ones, and the continual miniaturization of electronics allowed more signals, referred to as control channels, to be packed into the same package. While early control systems might have two or three channels using amplitude modulation, modern systems may include up to 20 or more using frequency modulation.

Remote control military applications are often not radio control in the sense of directly operating flight control surfaces and propulsion power settings, but instead take the form of instructions sent to a completely autonomous, computerized automatic pilot.

Instead of a "turn left" signal that is applied until the aircraft is flying in the right direction, the system sends a single instruction that says "fly to this point".

One of the most remarkable examples of remote radio control of a vehicle is the Mars Exploration Rover seen below (**Fig 41**).

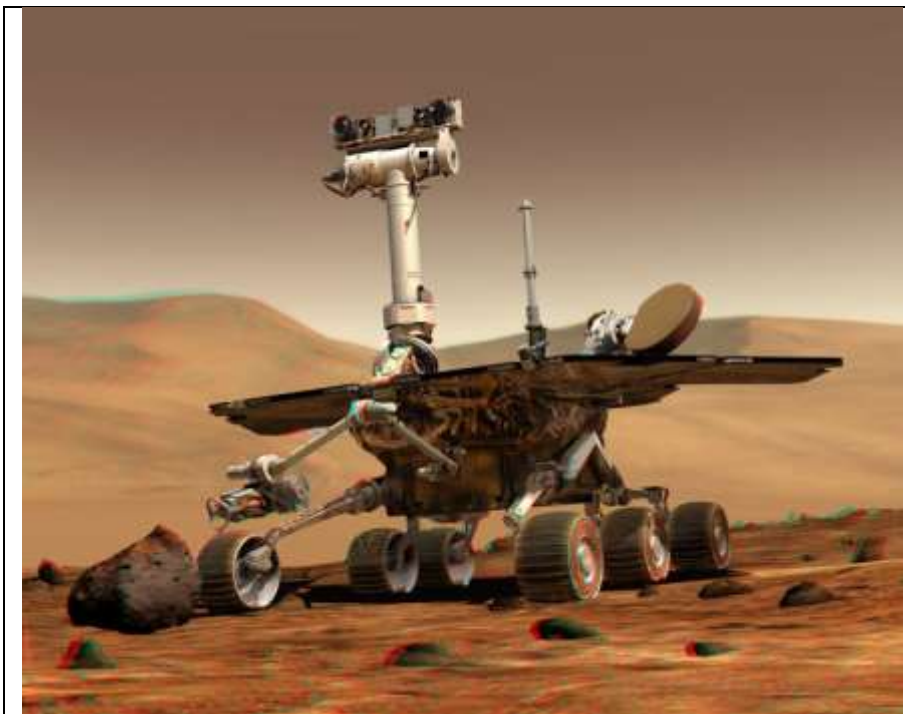
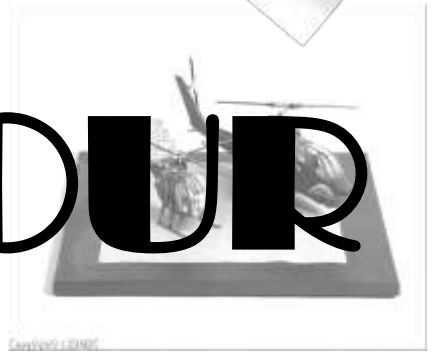
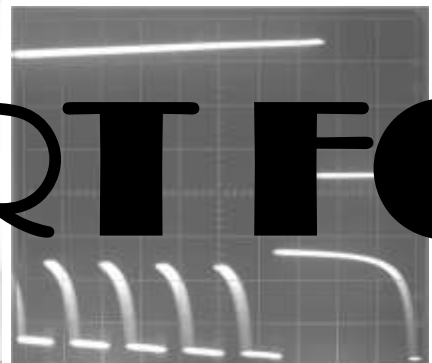
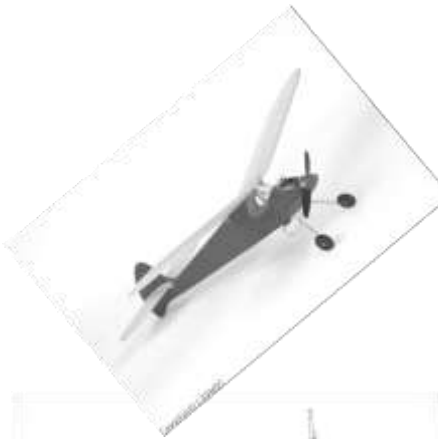

Fig 41 Mars Exploration Rover (3D Picture)

Today radio control is used in industry for such devices as overhead cranes and marshalling yard locomotives.

END OF PART 3

HISTORY OF RADIO AND RADIO CONTROL



PART FOUR

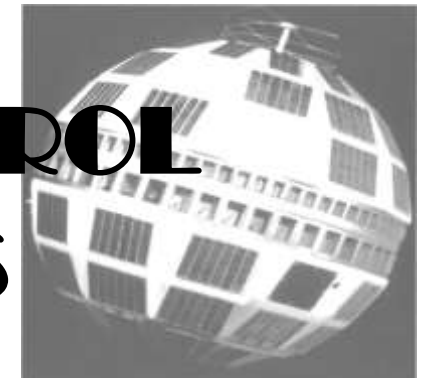

RADIO CONTROL SYSTEMS

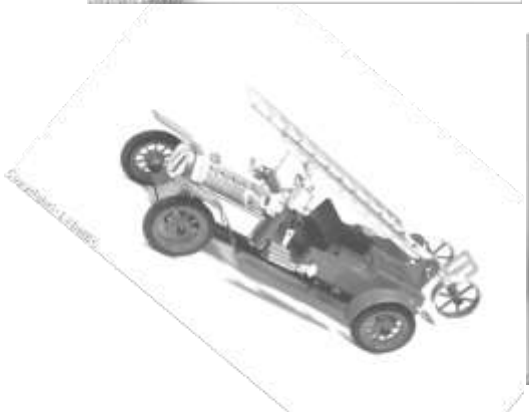

HISTORY OF RADIO AND RADIO CONTROL

Sequential Control

Early transmitters were very basic and just transmitted an RF burst when activated. This was detected by the Receiver which in turn energised a relay operating an escapement which was either rubber band or clockwork driven. The escapement may be used to turn the rudder of a boat or aircraft e.g. Centre – Left – centre – right – centre - left – providing what is referred to as sequential control.

Pulse Tone Modulation

Later developments gave us transmitters with frequency modulation where the RF output frequency is modulated by individual audio tones which produce a RF modulated signal. The receiver responds to these individual tones by activating reed relays connected to escapements that operate the required functions.

AM or FM Pulsed Modulation

This is the current method used by modern 27MHz, 36MHz 40MHz and 2.4GHz radio control systems. Radio control systems that employ pulse modulation actuate the various controls using either servomechanisms, Relays or Power Controllers. These R/C systems have made 'proportional control' possible, where the position of the control within the model is proportional to the position of the control on the transmitter.

The Transmitter

The transmitter (**Figs 42 and 43**) control changes the width (duration) of a pulse for any given channel between 1 ms and 2 ms, 1.5 ms being the centre (neutral) position. Each function has its own pulse, where typically a four function transmitter transmits a train of four pulses followed by a long synchronisation pulse of 6ms to 12ms. This sequence is repeated continually sending a stream of control data every 14ms to 20ms.

NOTE: 1 SECOND = 1000 MILLI-SECONDS (ms)

1 MILLISECOND = 1 THOUSANDTH OF A SECOND

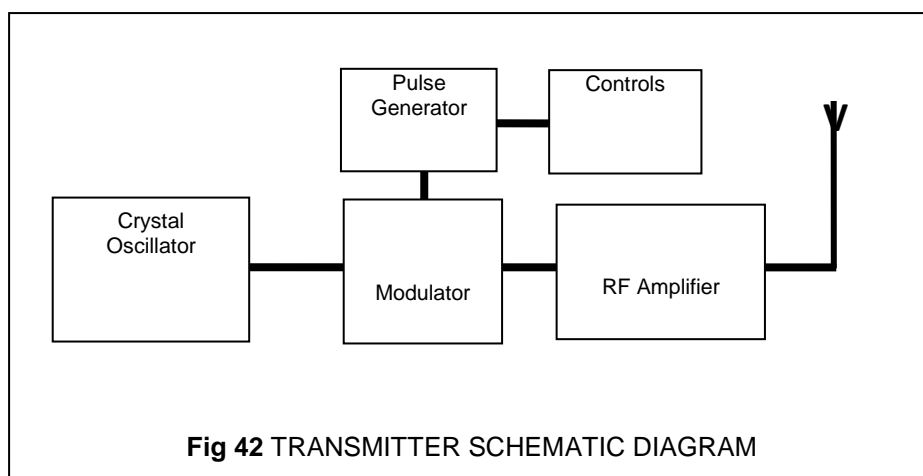

HISTORY OF RADIO AND RADIO CONTROL

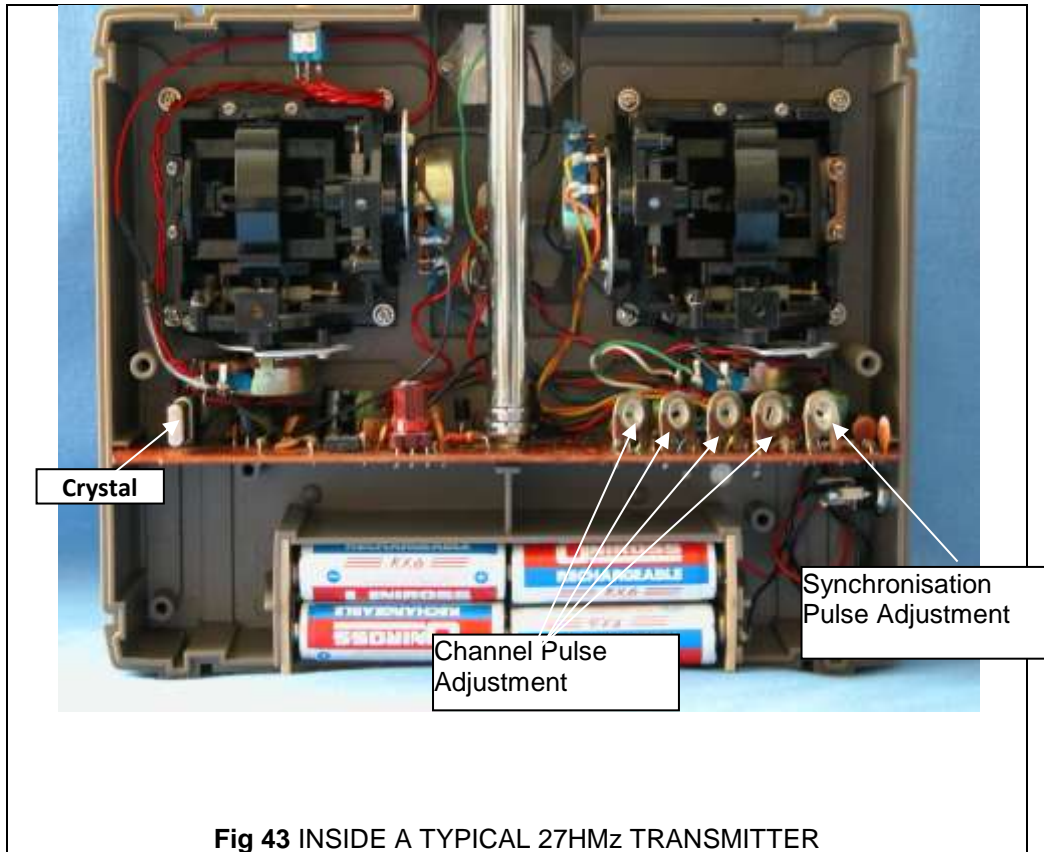

The Receiver

In the Receiver (**Figs 44 and 45**) the RF input is mixed and down converted into a demodulator which separates the channels using a decoder Integrated Circuit sometimes known as a Johnson Counter. The relative simplicity of this system allows receivers to be small and light, and has been widely used since the early 1970s. Receivers may be single or dual conversion (Superhetrodyne) with an IF frequency of 455 kHz (single conversion) or 10.7MHz and 455 kHz for dual conversion.

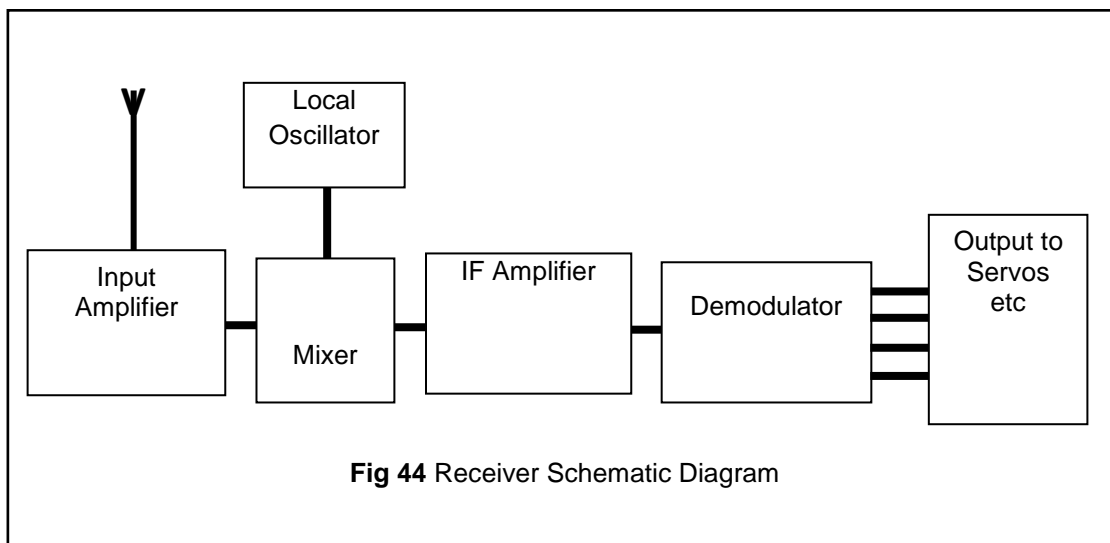

HISTORY OF RADIO AND RADIO CONTROL

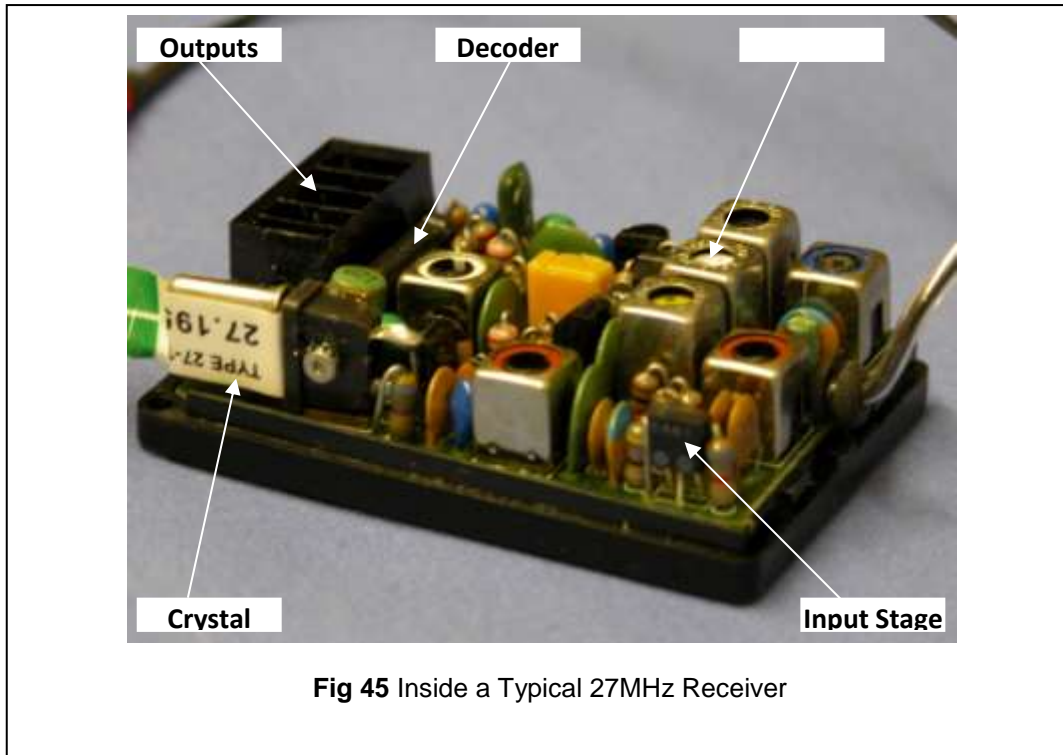

2.4GHz Systems

2.4GHz radios (Figs 46 and 47) operate using the same pulse modulation system, but use a different RF operating system known as **Spread Spectrum**, of which there are a number of system types in use. The two types described below are that of **Futaba** and **Spektrum**

It should be noted that Tesla was granted a US patent in 1903 for a **Frequency Hopping System** and Churchill/Roosevelt used a similar system to communicate with each other during the 2nd World War.

Futaba – Frequency Hopping

The Futaba system utilises all the 80 available channels within the 2.4GHz allocated band and randomly switches channels every two milliseconds. The idea being that if there is interference on any channel, it will only be a problem for 2ms. This type of system is called Frequency Hopping Spread Spectrum (FHSS).

Spektrum DSM/DualLink

The Spektrum system is described as DSM/DualLink Digital Spread Spectrum. With DualLink, the transmitter randomly selects two clear frequencies from the band, locks on to these and transmits the same information on both simultaneously. If one transmission path is corrupted by interference then the other one is almost sure to be satisfactory. This type of system is called Direct Sequence Spread Spectrum.

HISTORY OF RADIO AND RADIO CONTROL

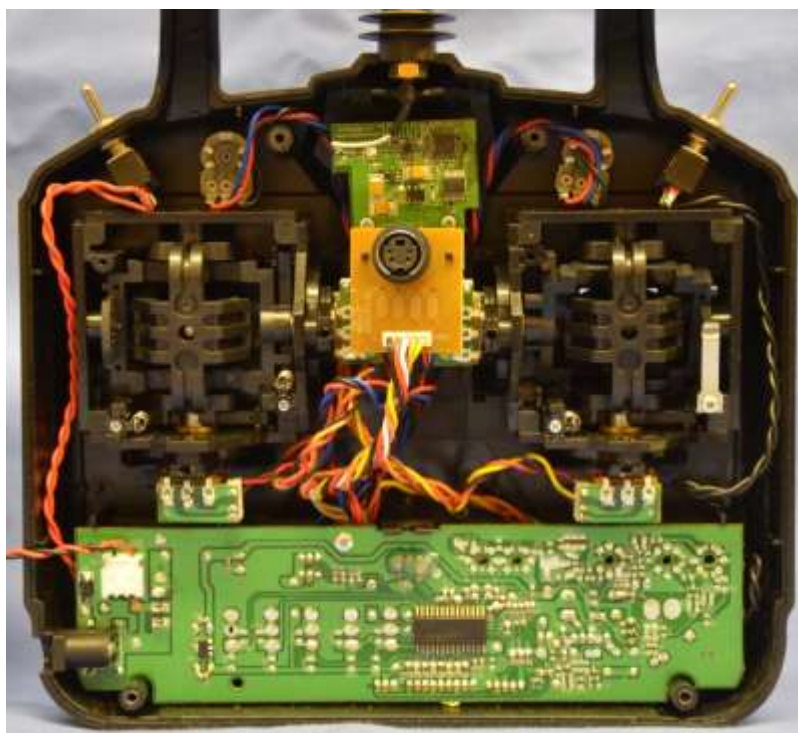

Fig 46 Inside a Typical 2.4GHz Transmitter

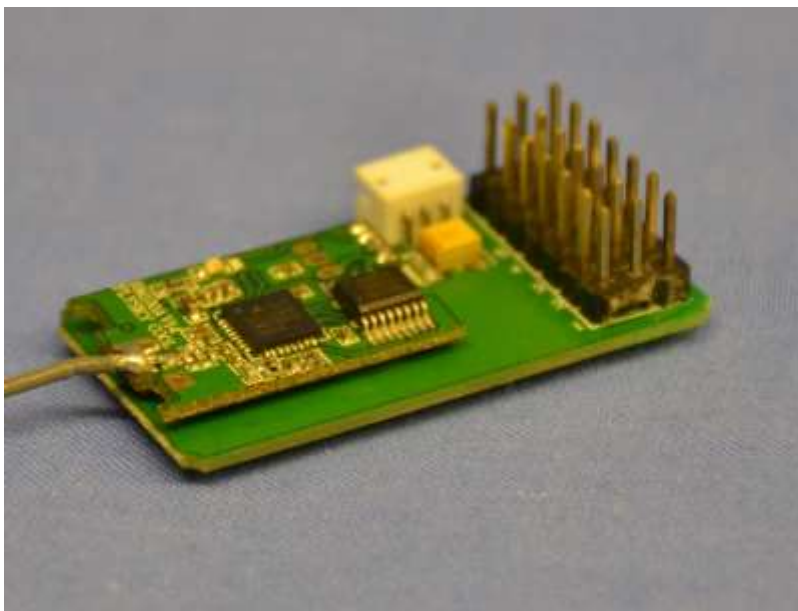
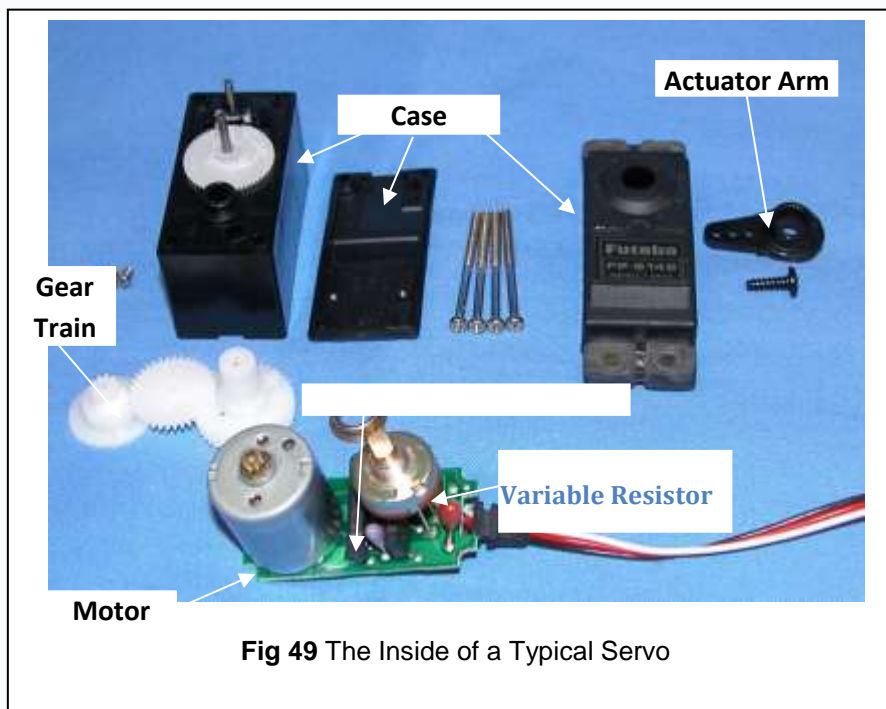
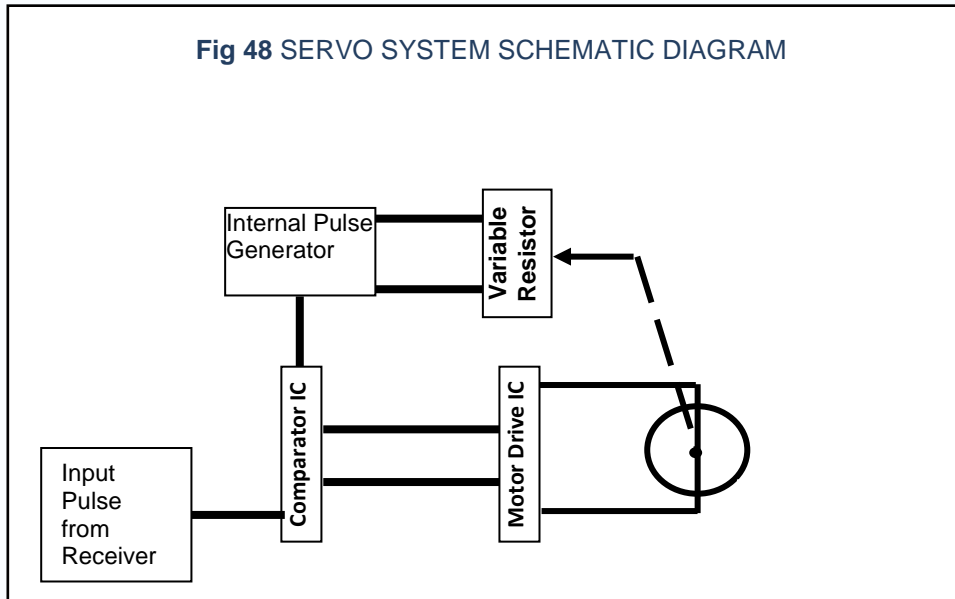

Fig 47 Inside a Typical 2.4GHz Receiver

HISTORY OF RADIO AND RADIO CONTROL

The Servo

The servo (**Figs 48 and 49**) responds directly to the pulse output from the receiver using a comparator circuit, the output of which activates an electric motor coupled to a reduction gearbox. This is linked to a variable resistor 'potentiometer' which rotates an arm or a lever on the top of the servo. The variable resistor controls an internal pulse generator whose pulse width is proportional to the servo's output arm position, this is then compared with width of the input pulse and the motor is driven until a match is obtained.



HISTORY OF RADIO AND RADIO CONTROL

The Electronic Speed Controller

The diagram and picture is of an Electronize Electronic Speed controller (ESC) (Figs 50 and 51). These ESC use PIC (Programmable Integrated Circuit) Microcontrollers to perform all their functions. The microcontroller is programmed such that it responds to the input pulse changes in order to produce a variable output pulse to control the speed of an electric motor

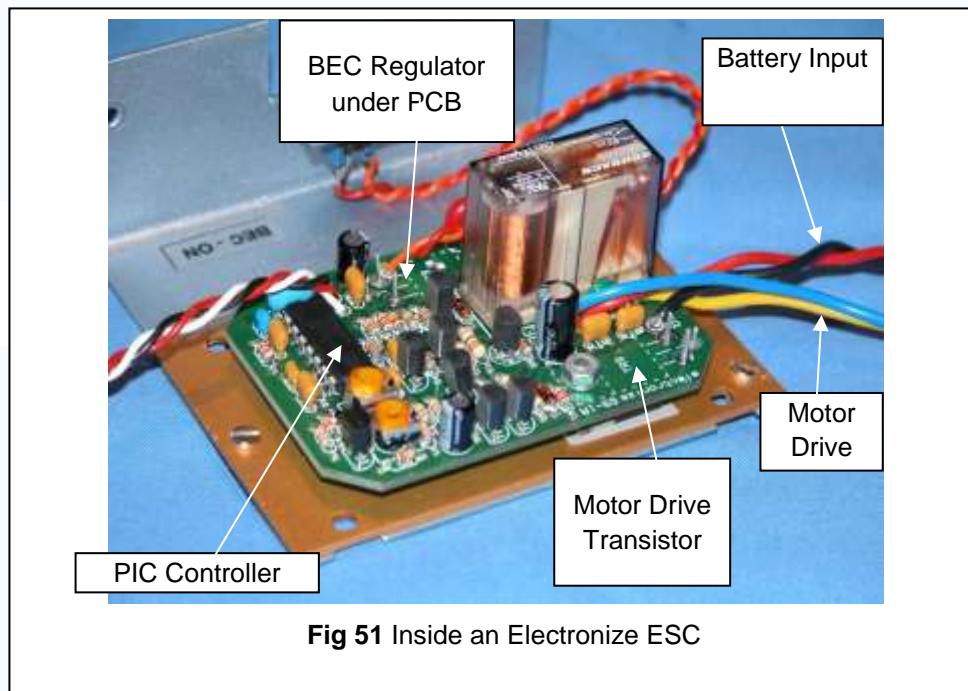
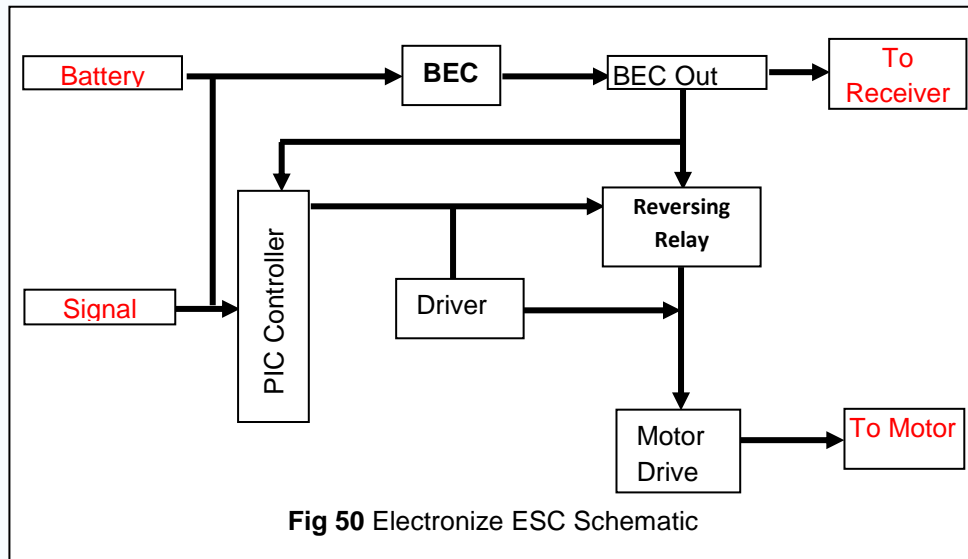

HISTORY OF RADIO AND RADIO CONTROL

Mtronics ESC

With the early versions of these ESC's it was necessary to go through an initial set-up procedure to determine the neutral and end stop positions of the Transmitter control. The later versions are just Plug and Play. Please note when using these Plug and Play types that it is essential that the throttle control is set to the neutral position before switching on the Receiver (**Fig 52**).

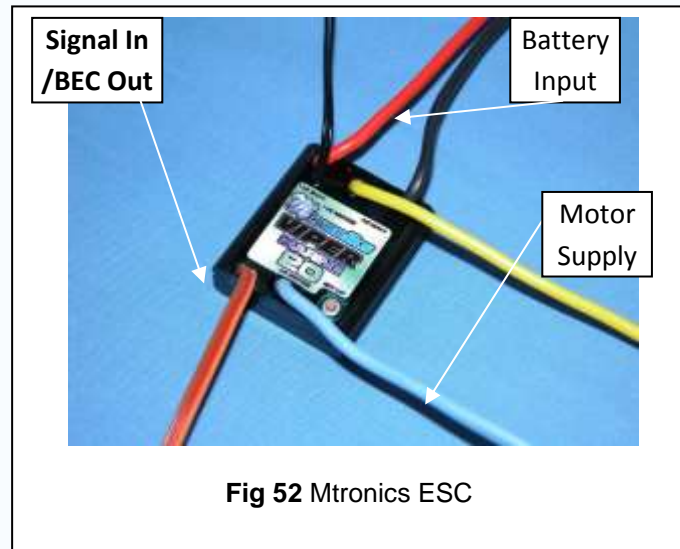

Fig 52 Mtronics ESC

The Relay Switcher

These devices operate relays that can be used to power/operate any number of devices within a model. The relays are switched on in proportion to the control stick position and may be latching or non-latching (**Figs 53 and 54**).

The RC pulse is applied to the input of an IC amplifier via a detector. The output of the IC amplifier is connected to a transistor which drives a relay that may be used to operate function(s) within a model.

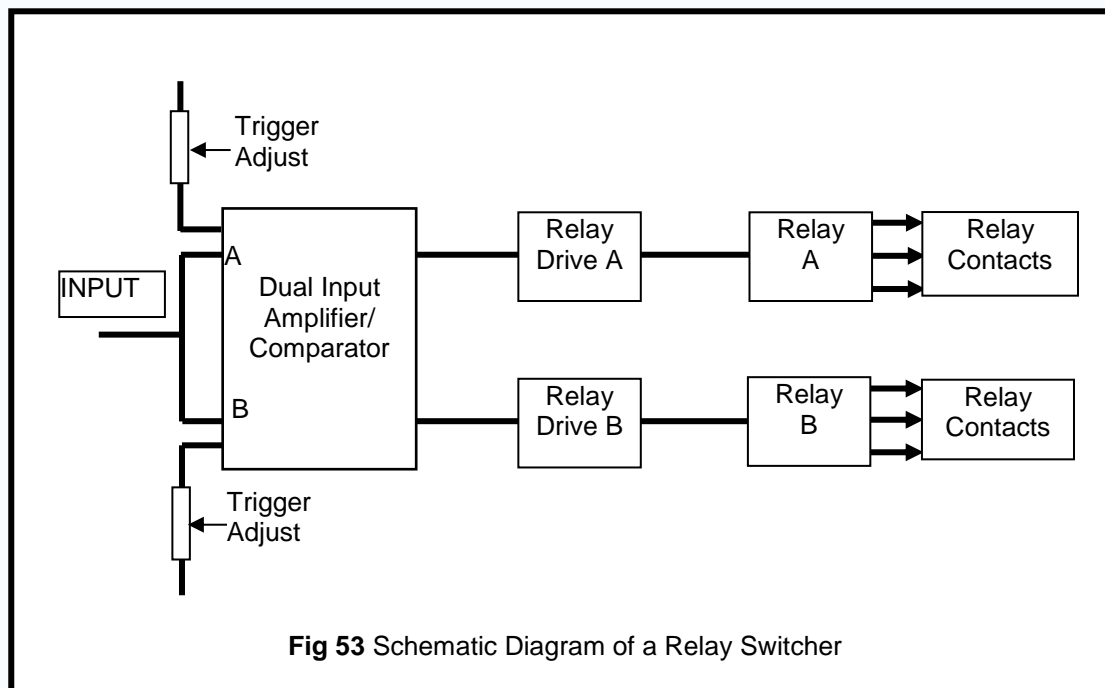
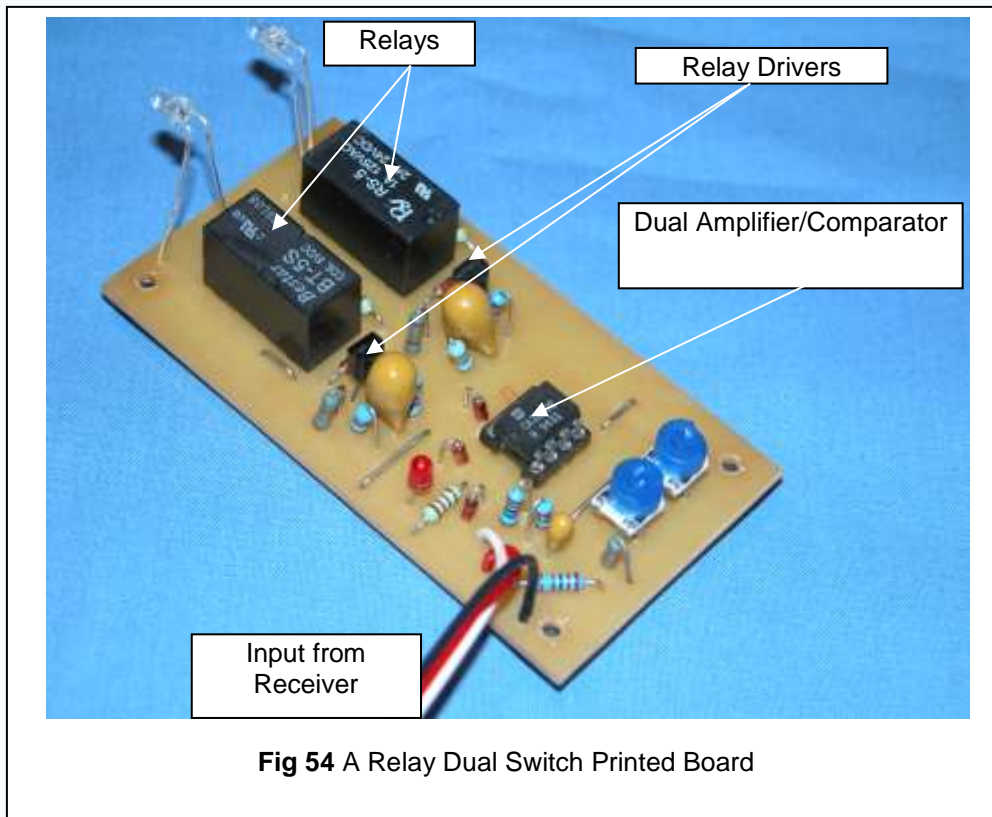

Fig 53 Schematic Diagram of a Relay Switcher

HISTORY OF RADIO AND RADIO CONTROL



The Electronic Switcher

These devices operate power switching transistors and can be used to power a number of devices within a model. (Figs 55 and 56)

An IC generates a control pulse which is compared with the incoming RC pulse. When the input pulse is greater than the internal pulse, an error signal is generated by the IC, this is connected to a switching transistor which is used to operate function(s) within a model.

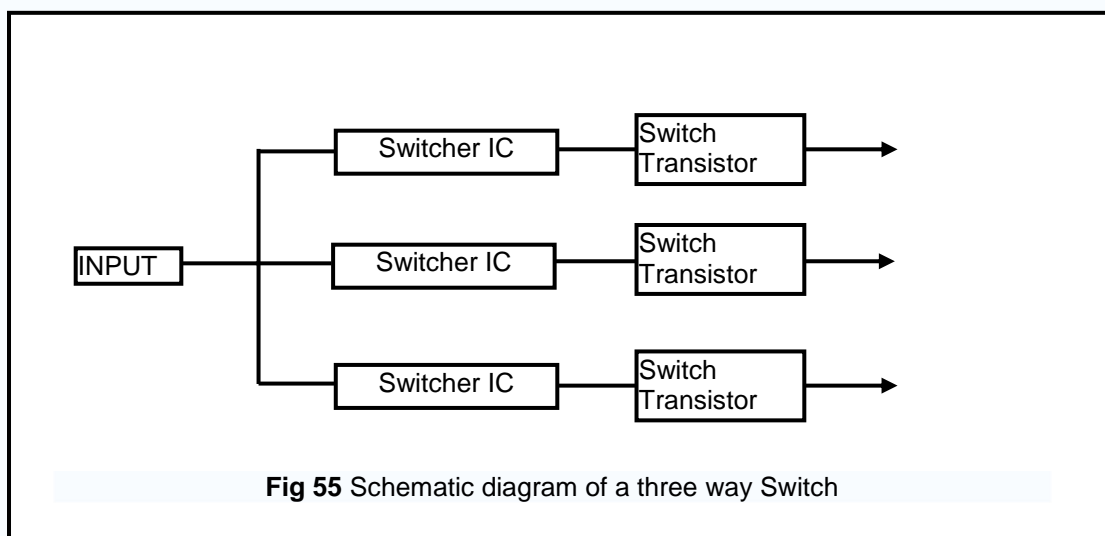

HISTORY OF RADIO AND RADIO CONTROL

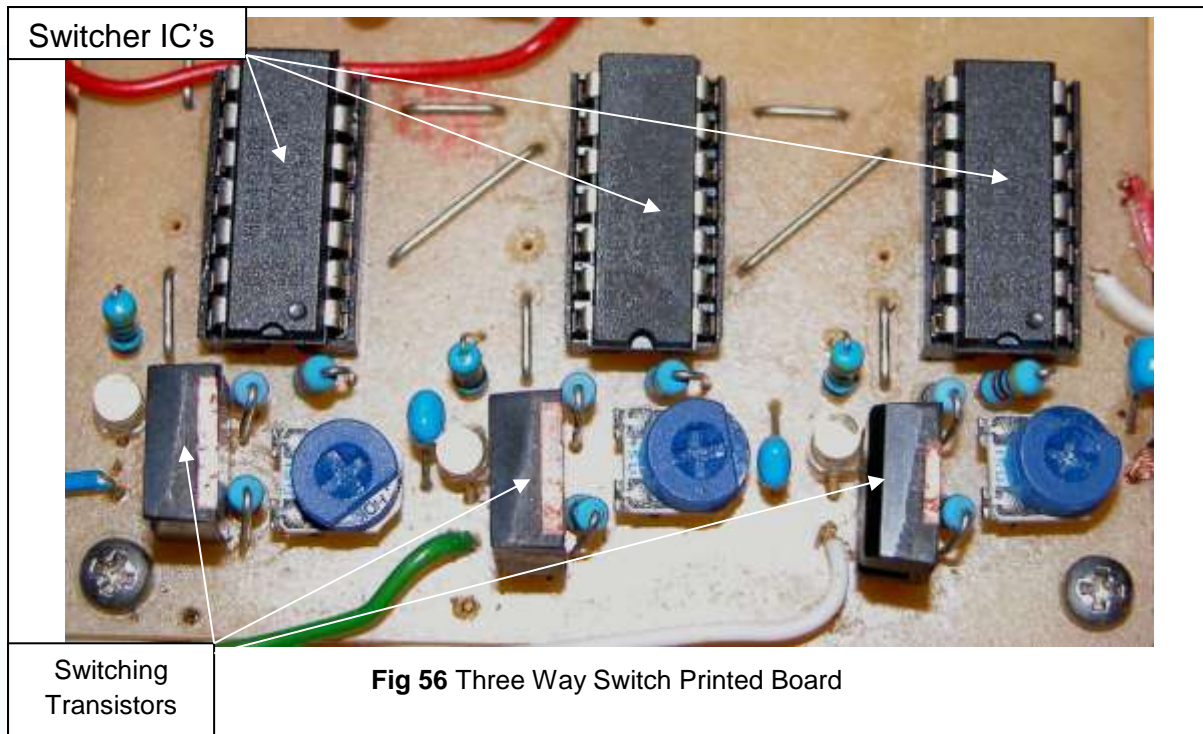

Please Note: Details of a number of electronic circuits and their construction may be found on the L&DMBC website

www.lutonmodelboat.co.uk

The Mixer Unit

These devices mix the input pulse signals from the Receiver that control both Rudder and Motor Speed Controllers (designed for use with multi-prop boats). The mix of the signals is such that it controls the speed of the left (port) and right (starboard) motors driving the propellers in proportion to the position of the rudder (Figs 57, 58 and 59).

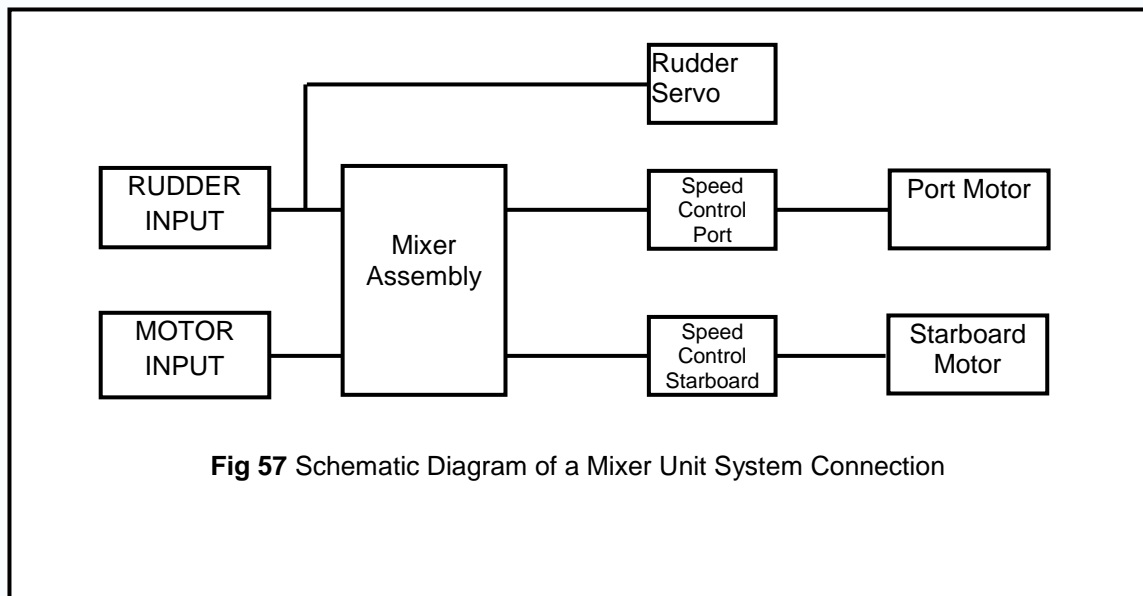

Fig 57 Schematic Diagram of a Mixer Unit System Connection

HISTORY OF RADIO AND RADIO CONTROL



Fig 58 Mtronics V Tail Mixer

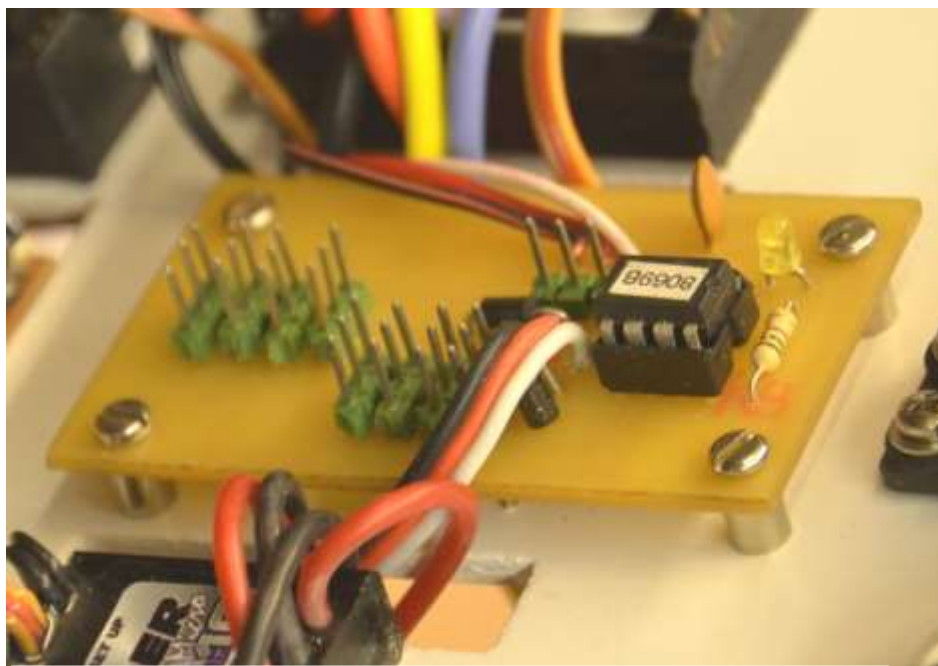

Fig 59 A Home Built Mixer Unit

The Integrated Circuit

Most of the modern day radio control devices contain Integrated circuits. These are manufactured using a combination of printing/plating and Laser etching techniques.

Typically they are manufactured on 3 inch diameter glass wafers (**Figs 60 and 61**) using layers of Germanium, Silicon and Gallium - Arsenide, together with other materials which are spun and etched onto the surface of the wafer to form many individual Integrated Circuits.

HISTORY OF RADIO AND RADIO CONTROL

When the plating/etching process has been completed each individual Circuit on the wafer is tested and those that are found to be faulty identified by scratching out. The remainder are diamond scored and broken out of the wafer into tiny individual circuits which are then mounted onto holders and sealed. Pictures of such a wafer are shown below.

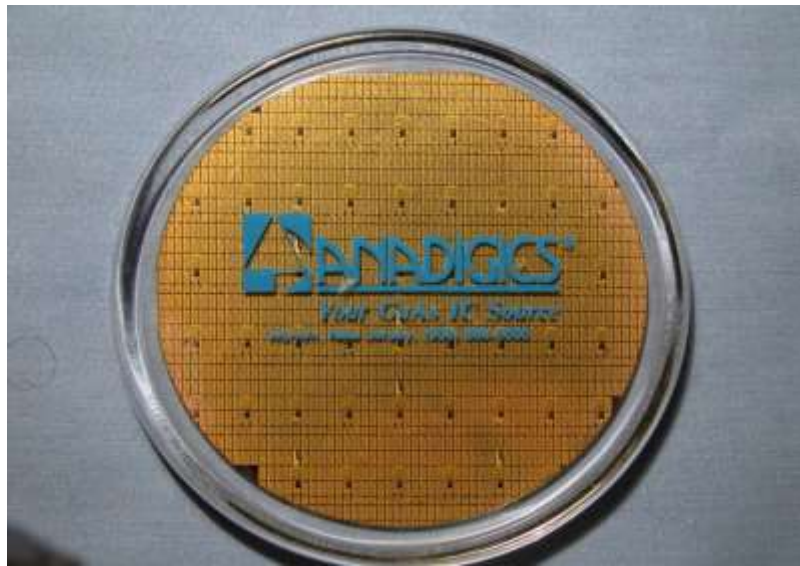

Fig 60 A Typical Three Inch Wafer



Fig 61 The Wafer magnified to show the individual IC's (actual size about 1x2.5mm)

END OF PART 4

HISTORY OF RADIO AND RADIO CONTROL

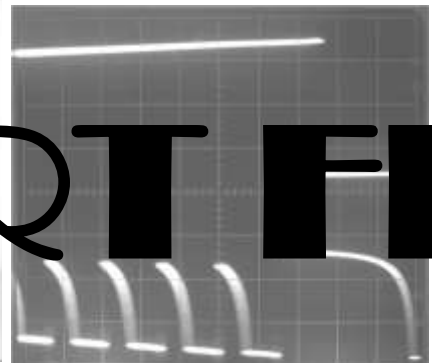
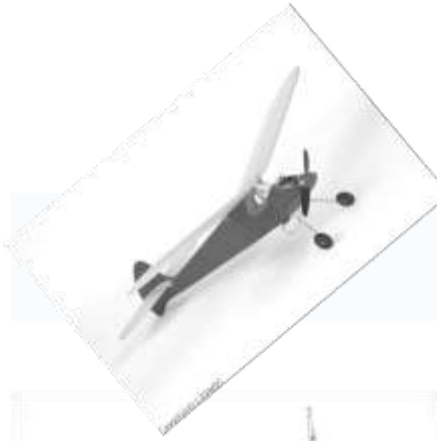

PART FIVE

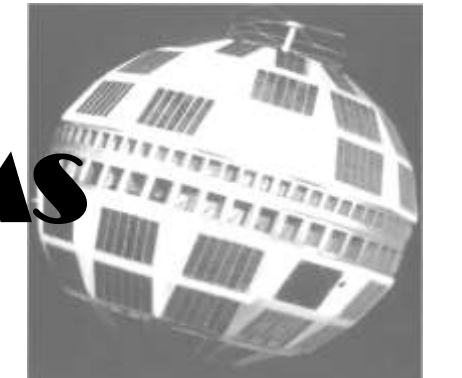
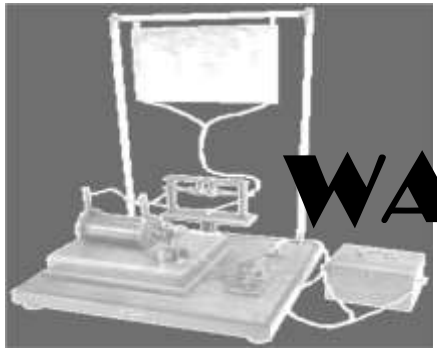

**WAVEFORMS
AND**



CONTROL

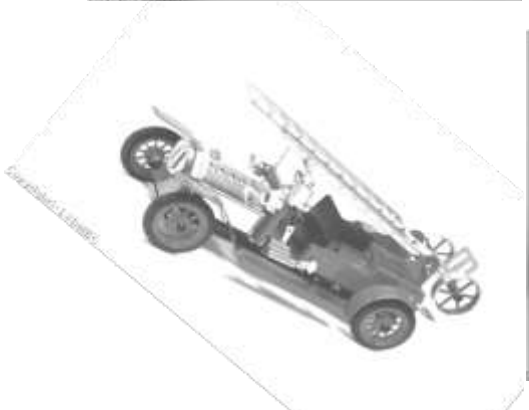

HISTORY OF RADIO AND RADIO CONTROL

In Part 4 of this article I described how some of the different radio control items work, all being based on the generation and control of a 1 to 2mSec pulse. In the final part and with the aid of some photographs we will look at the waveforms generated by the Transmitter and subsequently detected by the receiver. The equipment used to view the waveforms is called an Oscilloscope. We will examine the 1 to 2mSec pulse and see what effect it has when applied to a Servo, Electronic Speed Controller (ESC), Mixer and an Electronic Switch.

Fig 62 shows the RF output of four channel amplitude modulated (AM) Transmitter. The shaded area of the waveform is RF at 27MHz, which is being switched on and off by the modulation system of the transmitter. The first four pulses to the left are the four 1.5mSec channel pulses followed by the long synchronisation pulse. This pulse sequence is being repeated every 18 Milliseconds.

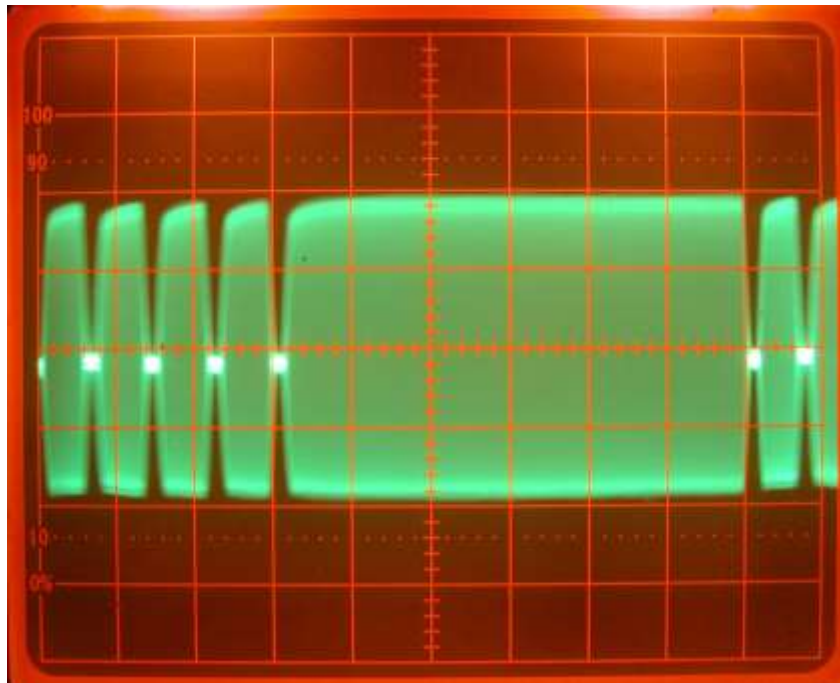

Fig 62

Fig 63 shows the RF output of a six channel Frequency modulated (FM) Transmitter. The shaded area of the waveform is RF at 40MHz. The FM modulation system within the Transmitter is changing the frequency of the 40MHz RF signal at a rate and magnitude proportional to the six channel pulses and one synchronisation pulse. Unfortunately the change in frequency is so very small it is not possible to actually see the frequency change on the oscilloscope, as one can only just discern the individual cycles of the 40MHz signal.

HISTORY OF RADIO AND RADIO CONTROL

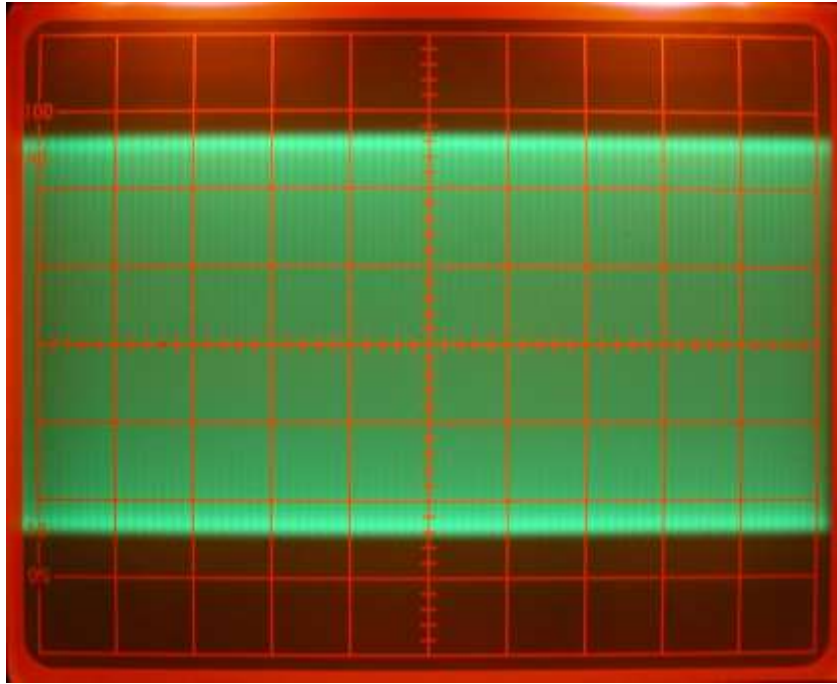

Fig 63

Fig 64 shows one of the detected pulses from the Receiver in its mid or neutral position (1.5mS). As the control on the Transmitter is moved to one extreme the pulse increases to 2.0mS (**Fig 65**). Moving to the other extreme it reduces to 1.0mS (**Fig 66**). The control over this pulse as mentioned earlier is the basis of modern day Radio Control, be it 27, 36, 40MHz or 2.4GHz - one such pulse is generated for each of the controlling channels which may be as little as 2 or greater than 12.

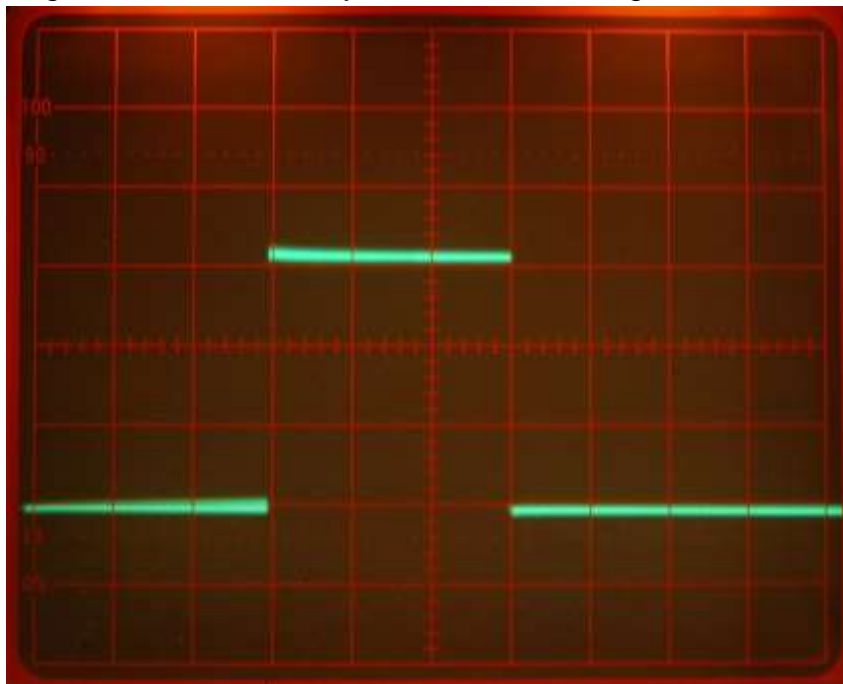

Fig 64

HISTORY OF RADIO AND RADIO CONTROL

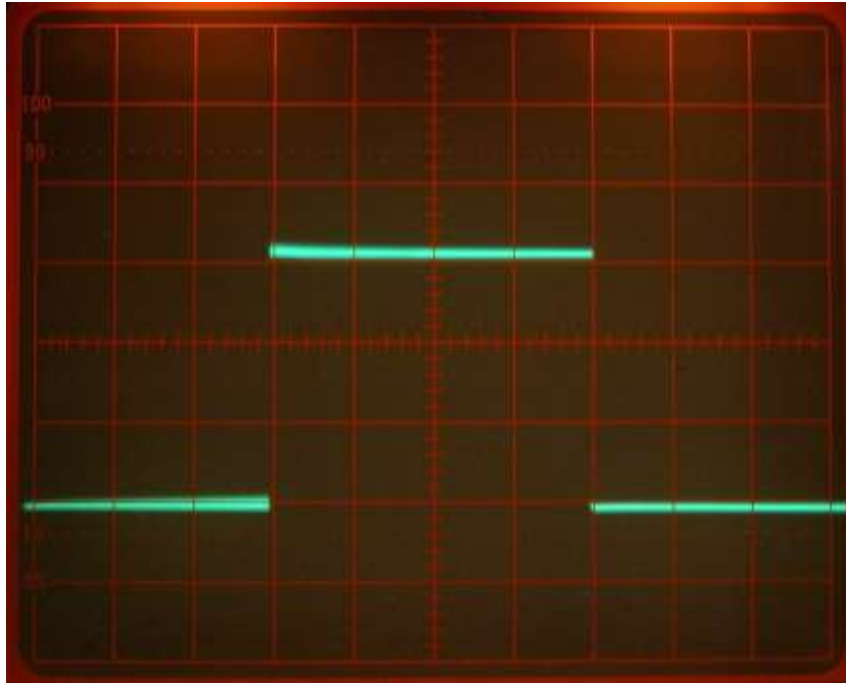

Fig 65

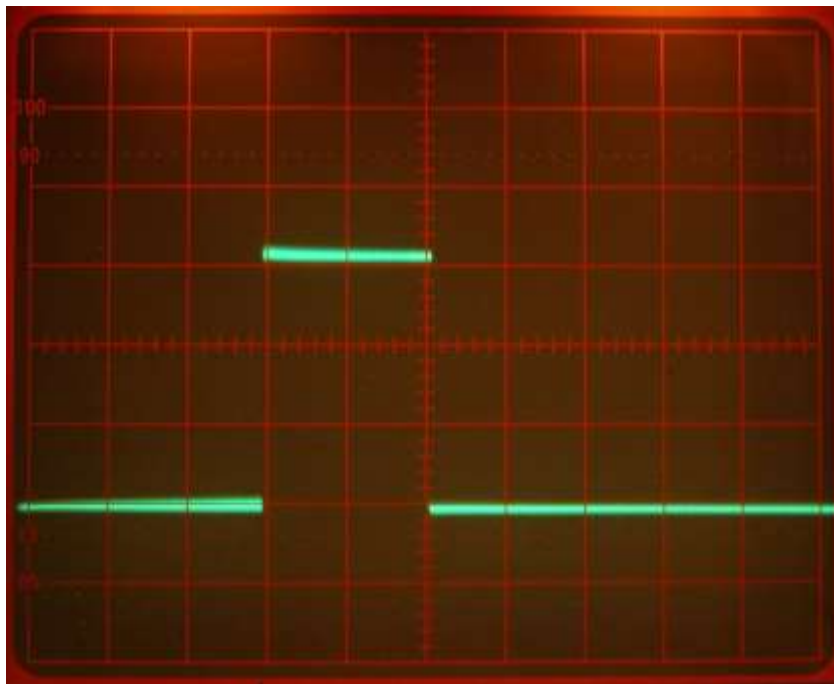

Fig 66

We will now look at the operation of an Electronic switch. This particular switch operates by comparing its own internally generated pulse with that of the incoming Radio Controlled pulse. In **Fig 67a/b** the upper (longer) waveform is that of the internal pulse and the lower (shorter) waveform is the incoming RC pulse. In this state the output of the integrated circuit (IC) is at a low (switched off) and thus the output drive transistor is also switched off. In **Fig 68a/b** the Lower RC pulse is still just shorter than the fixed pulse and therefore the output is still switched off. In **Fig 69a/b** the lower pulse is now longer than the internally generated one which results

HISTORY OF RADIO AND RADIO CONTROL

in the output of the IC being switched on thus switching on the output transistor which then supplies power to the device being controlled.

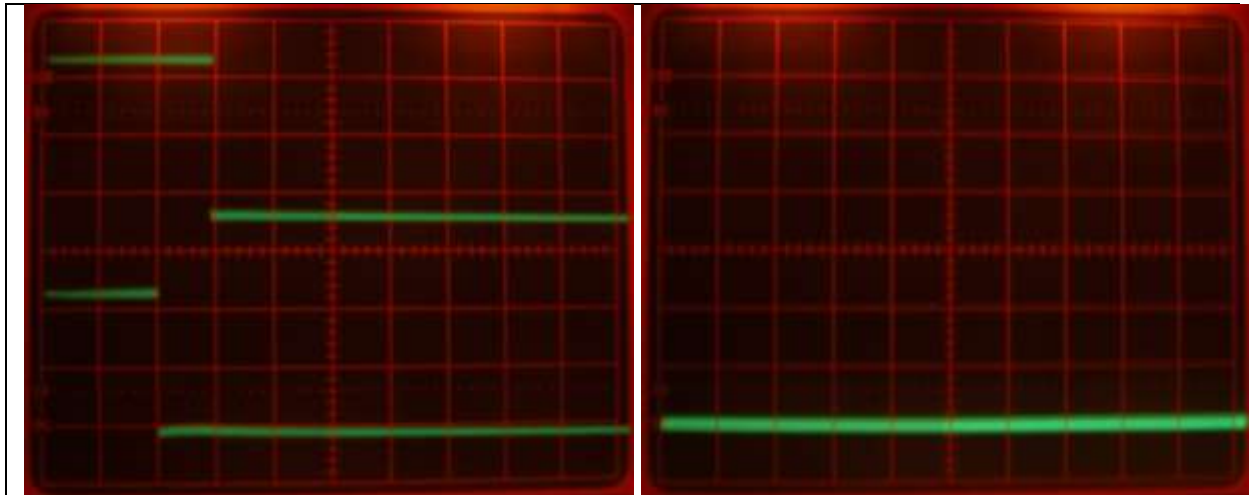

Fig 67a Internal pulse & RC Input Pulse

67b Output drive off

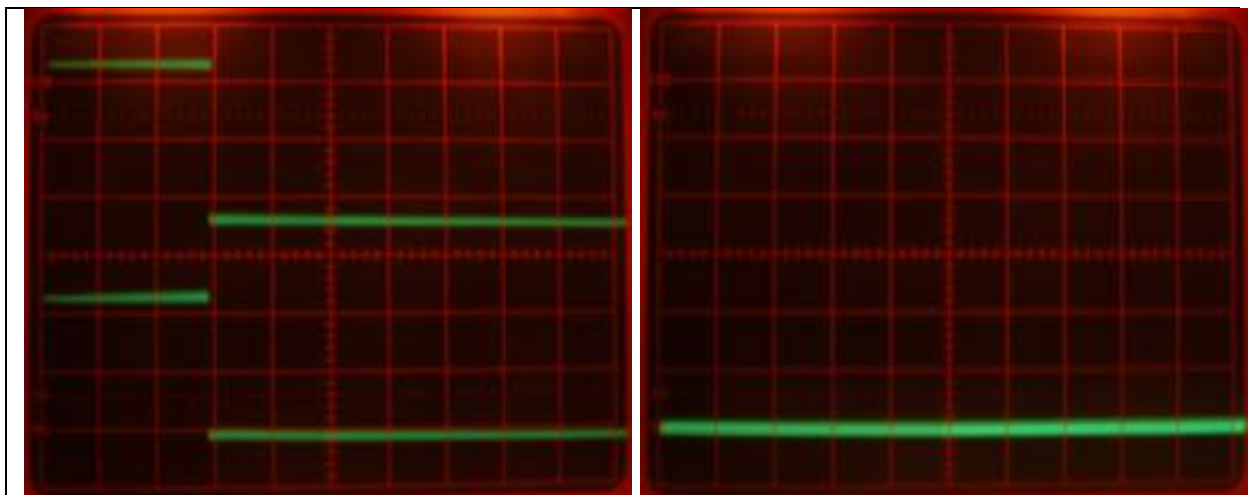

Fig 68a Internal pulse & RC Input Pulse

68b Output drive off

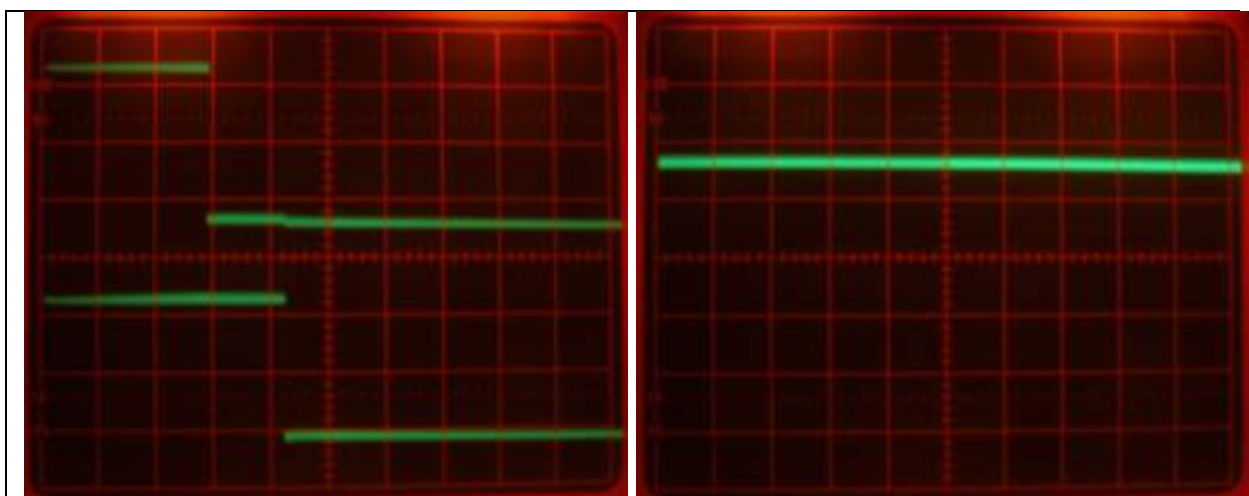

Fig 69a Internal pulse & RC Input Pulse

69b Output drive on

We will now look at the operation of a Relay Type switch. This particular switch operates by amplifying the incoming RC pulse and then detecting the resulting

HISTORY OF RADIO AND RADIO CONTROL

signal. This in turn then drives a transistor to switch on a relay. The lower waveform in **Fig 70a/b** is the incoming RC pulse set at 1.0mSec. The upper waveform is that of the detected output from the amplifier and the signal in the picture on the right is the power to the relay which indicates that it is off. As the incoming RC pulse is increased to about 1.3mSec the detected pulse starts to emerge (Fig 71a/b) until the increase of the incoming RC pulse at 2.0mSec is enough for the detector to switch the relay fully on (Fig 72a/b).

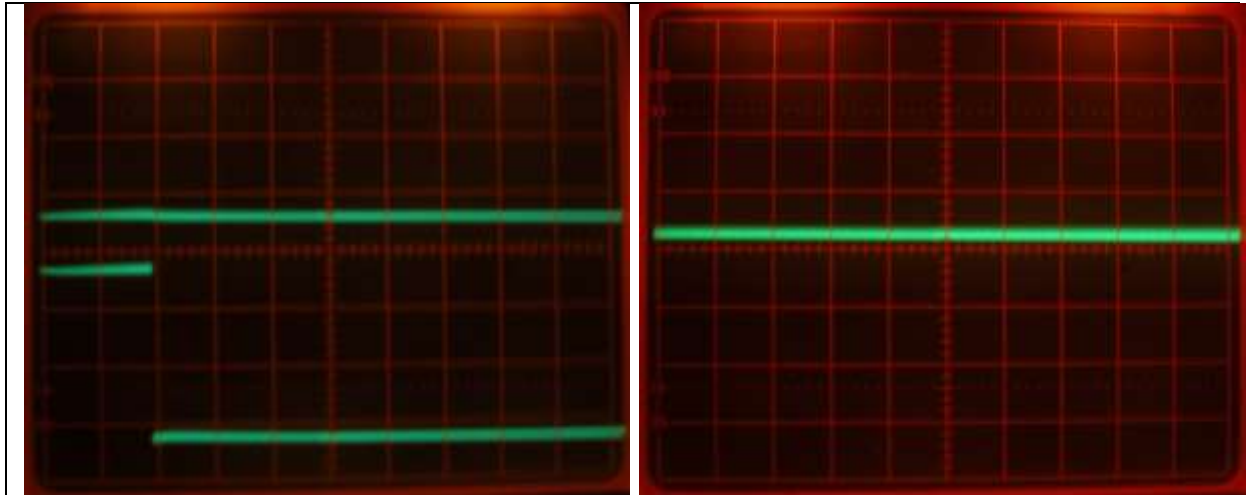

Fig 70a Input Pulse set at 1mSec

70b

Relay Drive Off

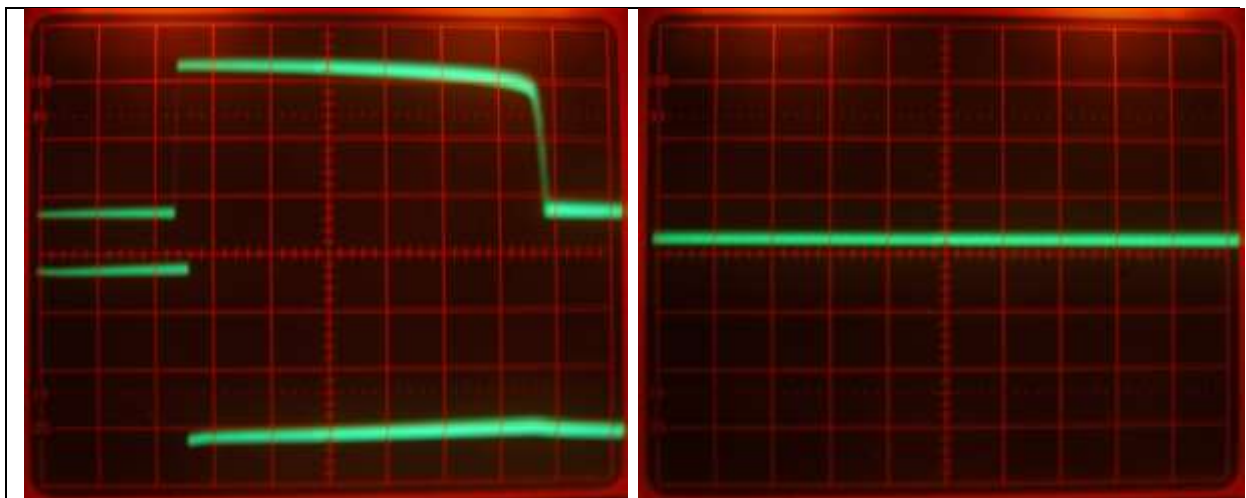

Fig 71a Input pulse set at 1.3mSec

71b

Relay Drive Off

HISTORY OF RADIO AND RADIO CONTROL

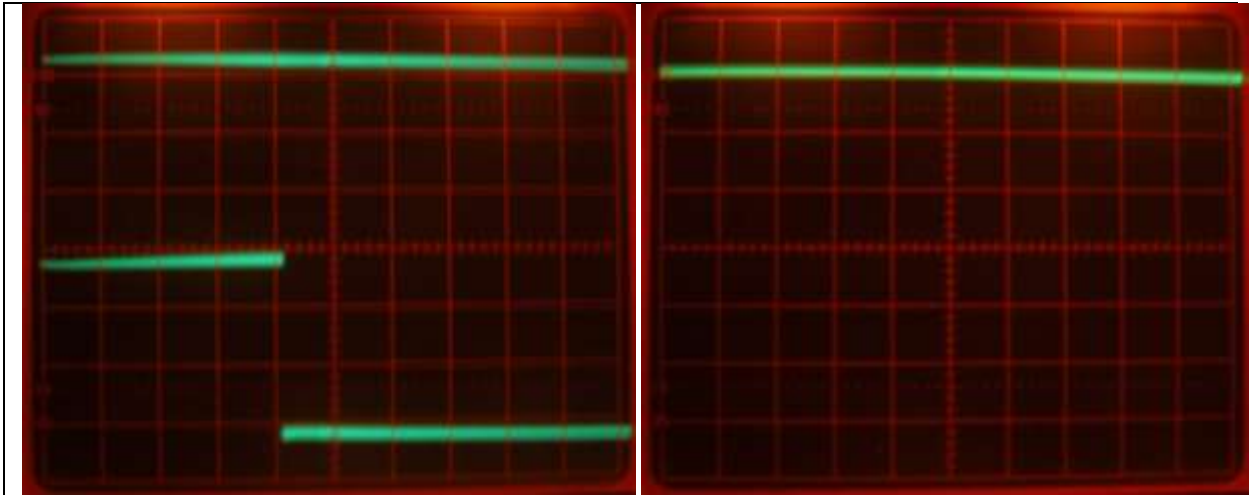

Fig 72a Input Pulse set at 2.0mSec

72b

Relay Drive On

The rudder is operated by a servo that is controlled by the incoming RC pulse. When the pulse moves in one direction so does the servo and thus the rudder is proportionally controlled. Fig's **73**, **74** and **75** show the RC pulse and Servo in the Port, Central and Starboard positions.

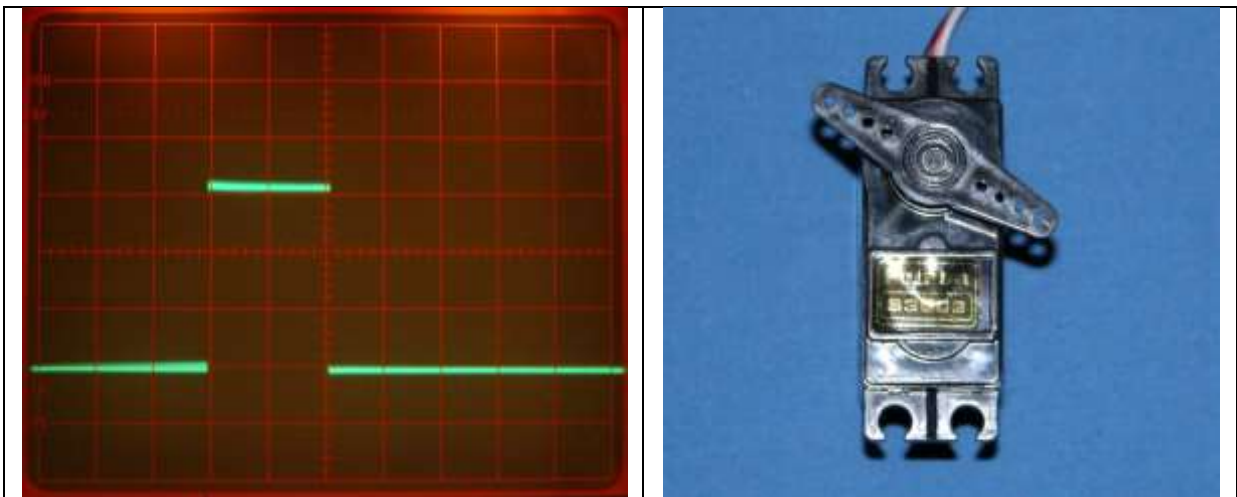

Fig 73 1mSec Pulse

Servo to Port

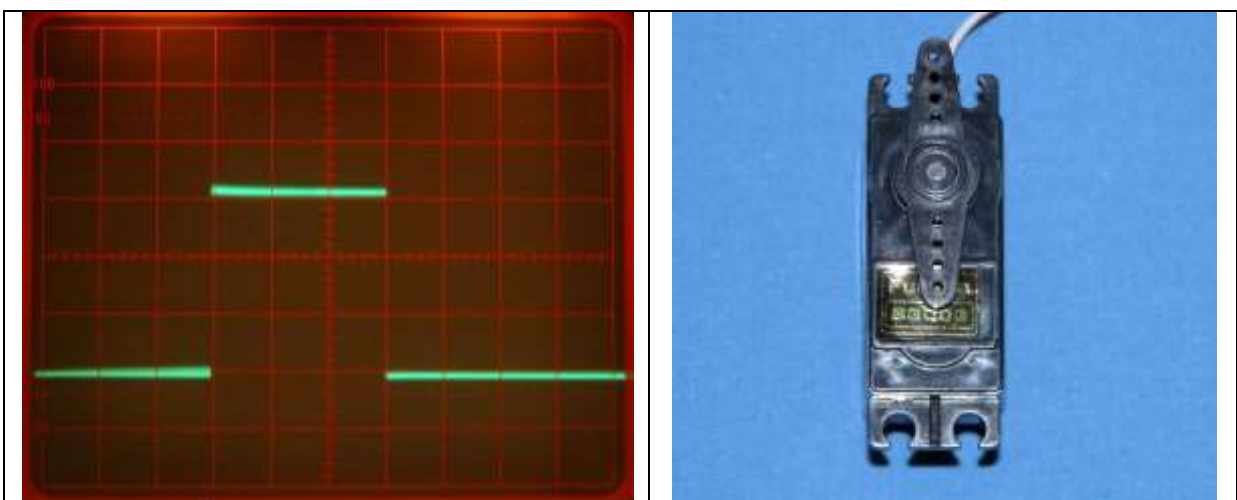

Fig 74 1.5mSec Pulse

Servo Central

HISTORY OF RADIO AND RADIO CONTROL

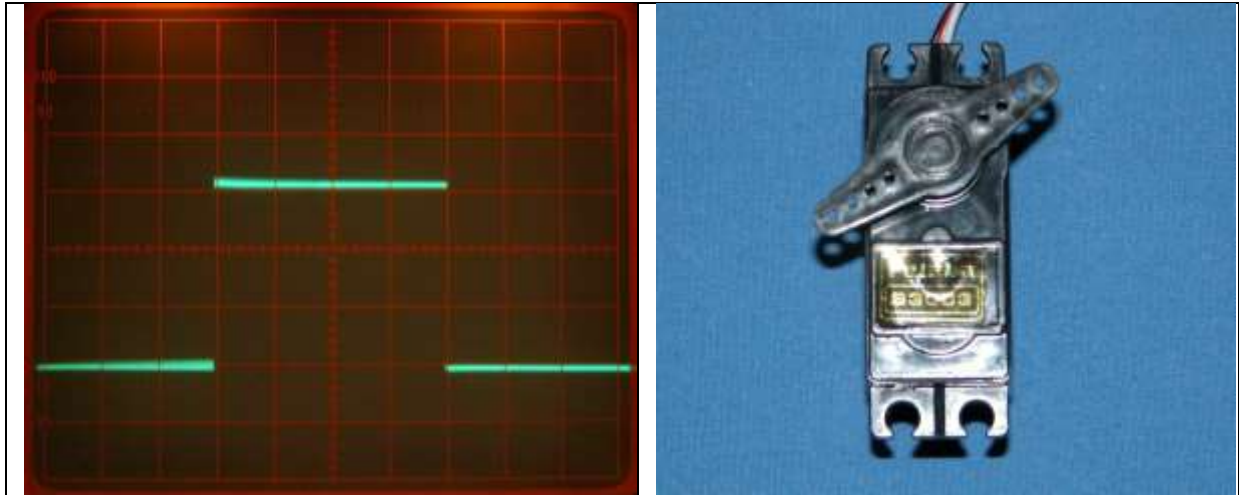

Fig 75 2mSec Pulse

Servo to Starboard

We can now observe the input and output pulses to and from an Electronic Speed Controller (ESC). The lower waveform is the incoming RC pulse and the upper waveform is the output drive to the motor. With the control in the neutral position (1.5mSec) the output to the motor from the ESC is zero (**Fig 76**).

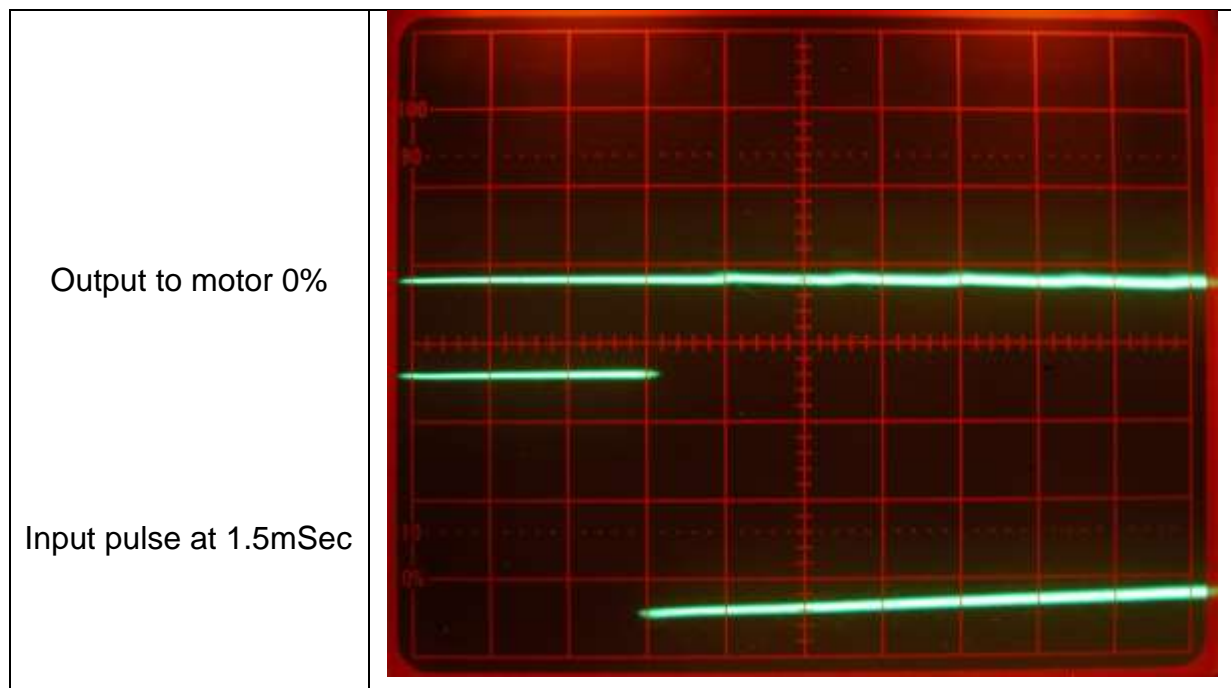

Fig 76

Moving the throttle control will result in the pulse width being reduced to 1.25mSec, thus causing the ESC to start up and produce a small pulsed output (**Fig 77**).

HISTORY OF RADIO AND RADIO CONTROL

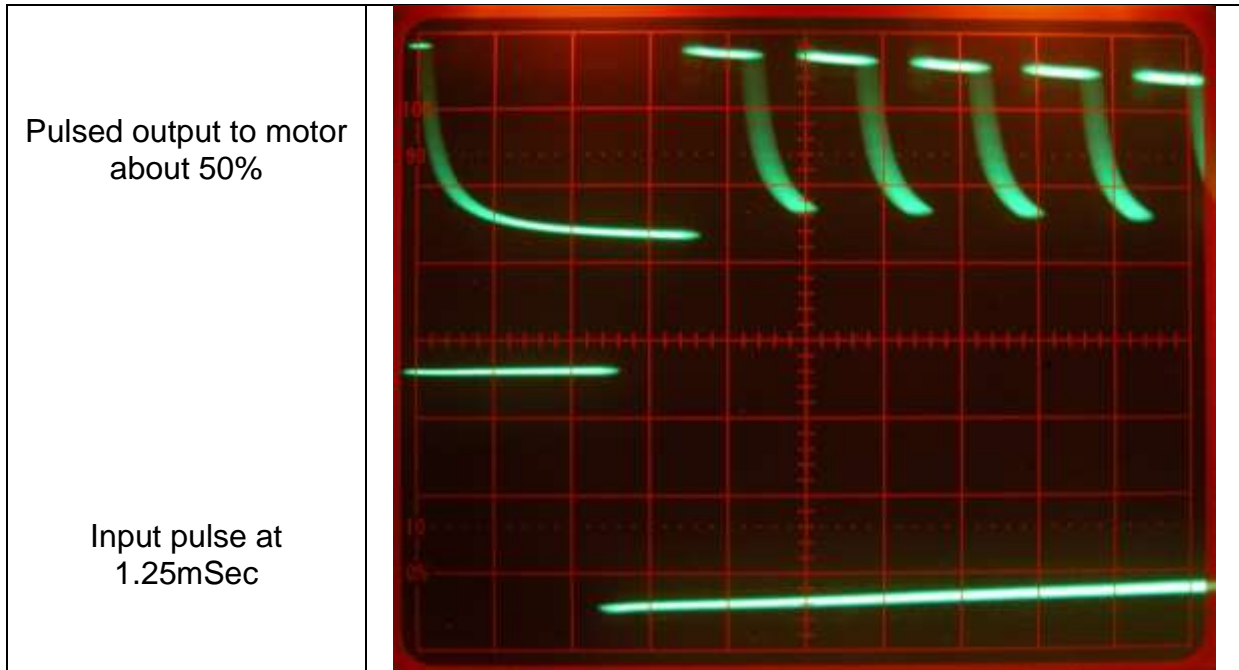

Fig 77

Moving the throttle control to its full extent reduces the pulse width to 1.0mSec and switches the ESC full on (**Fig 78**). The same thing will happen when moving the throttle control in reverse except that the output will produce a reversed polarity output.

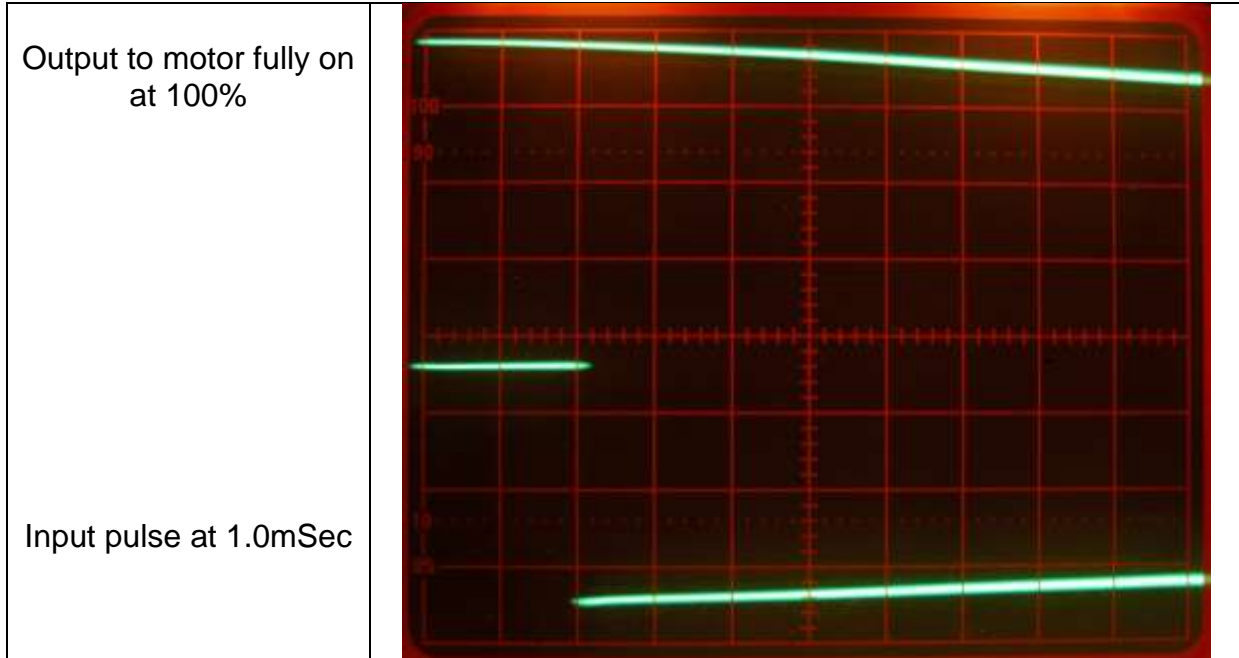

Fig 78

A twin screw vessel with two motors each connected to their own ESC's may also use a mixer to control the speed and direction of the motors in relation to the rudder position. Insert a mixer between the Receiver and the two ESC and set the rudder to the central position, the mixer then provides the same pulse output to each of the speed controllers (**Fig 79**).

HISTORY OF RADIO AND RADIO CONTROL

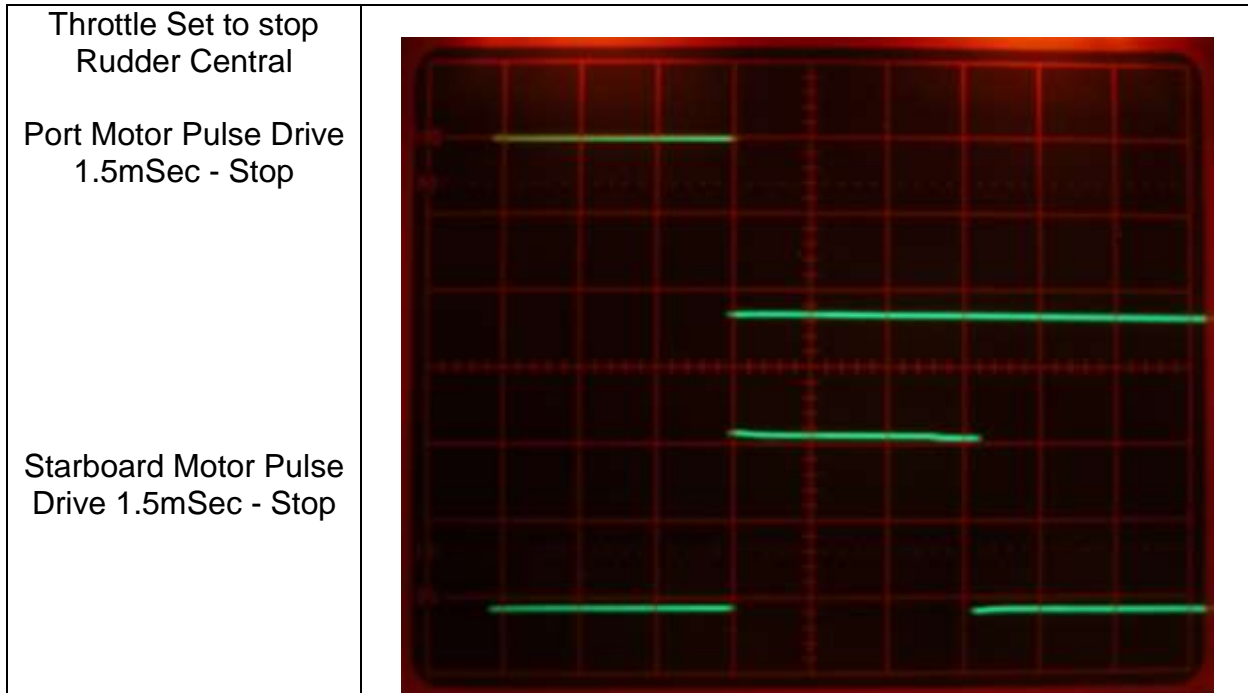

Fig 79

With the rudder set to Port or Starboard the situation is changed. The Figures below look at the drive pulses to each of the motors in relation to the rudder position. With the throttle set at zero, moving the rudder to Starboard (**Fig 80**) causes both the motors to turn on fully in the opposite direction (one pushing and the other pulling). This may allow the vessel to rotate (e.g. anticlockwise) within its own length providing the pairs of motors and propellers are reasonably matched.

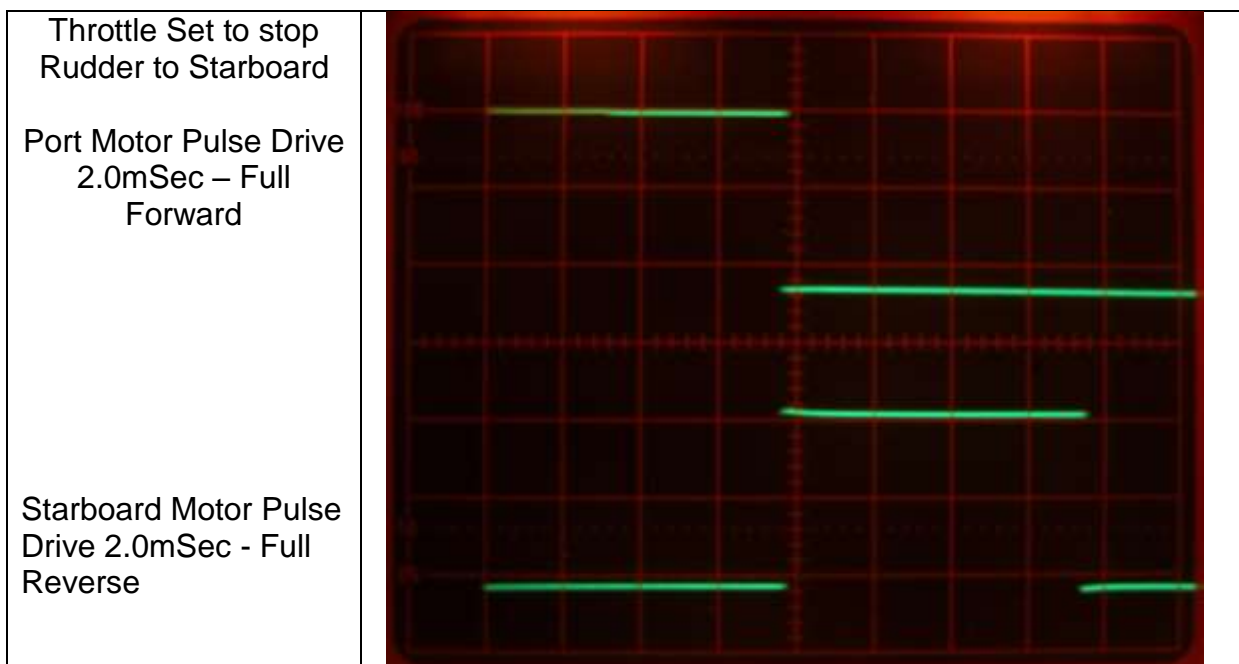

Fig 80

HISTORY OF RADIO AND RADIO CONTROL

Move the rudder to port (**Fig 81**) will also cause both the motors to turn on fully but in a clockwise direction.

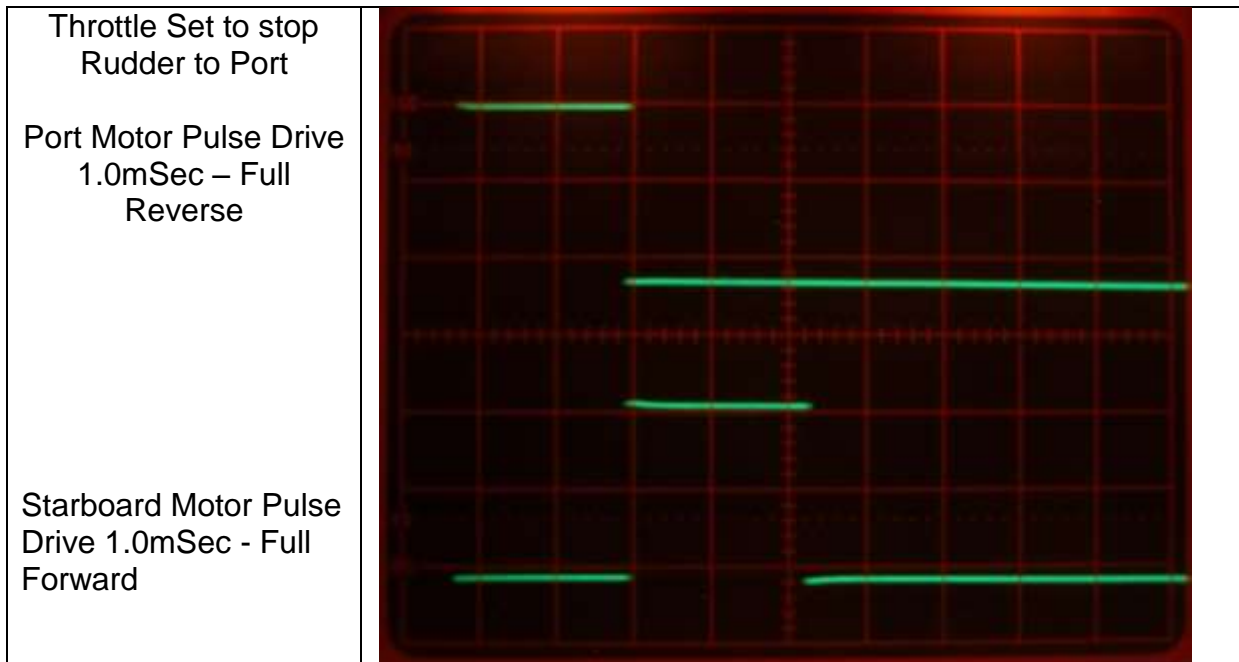

Fig 81

If we move the throttle to the full ahead position and then set the Rudder fully to port the starboard motor will continue to run at full power and the port motor will slow down. The result of this action will be to drive the vessel to port, thus assisting the rudder in turning the vessel (**Fig 82**)

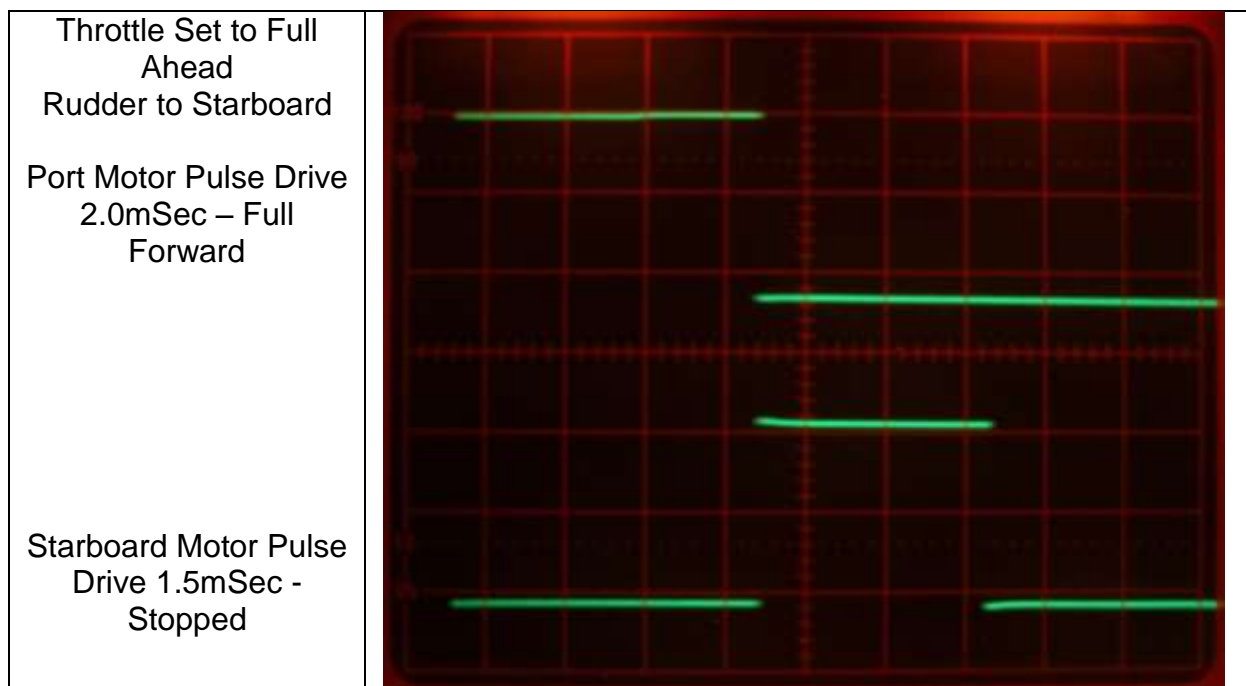

Fig 82

HISTORY OF RADIO AND RADIO CONTROL

If the Rudder is positioned fully to starboard the port motor will continue to run at full power and the starboard motor will slow down. The result of this action will be to drive the vessel to starboard, assisting the rudder in turning the vessel (**Fig 83**).

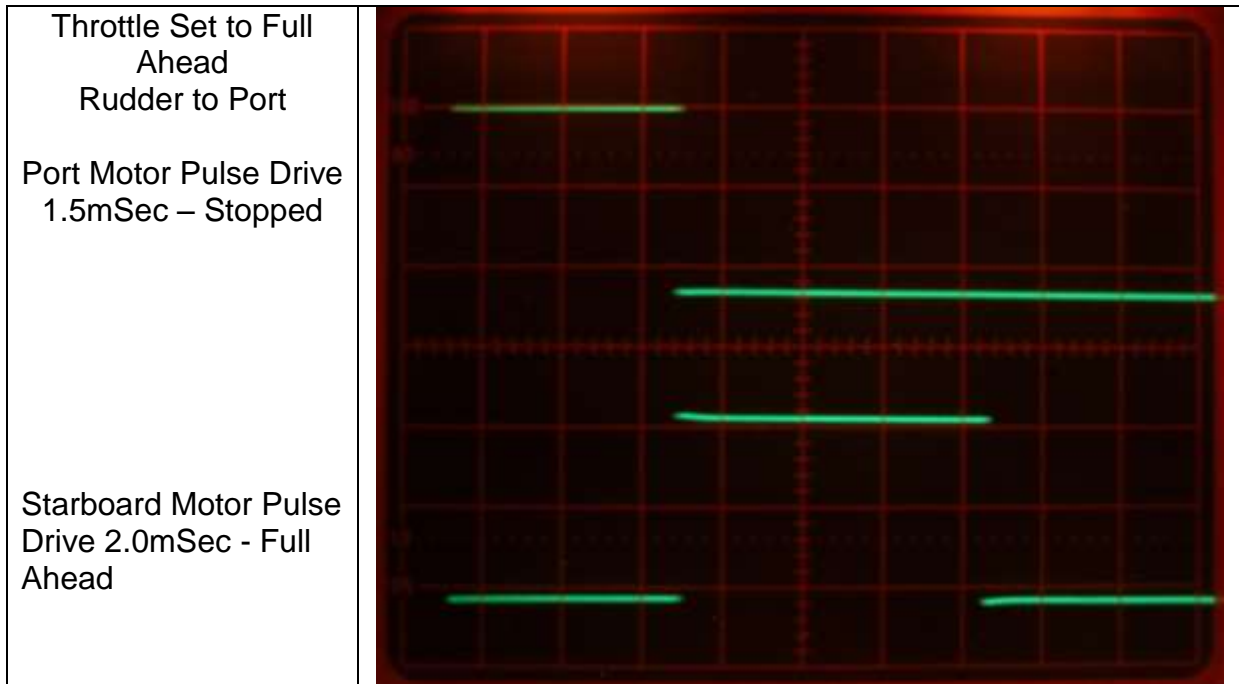

Fig 83

If the throttle is set fully in reverse then the above actions are repeated but in the opposite direction see pictures **84 and 85**.

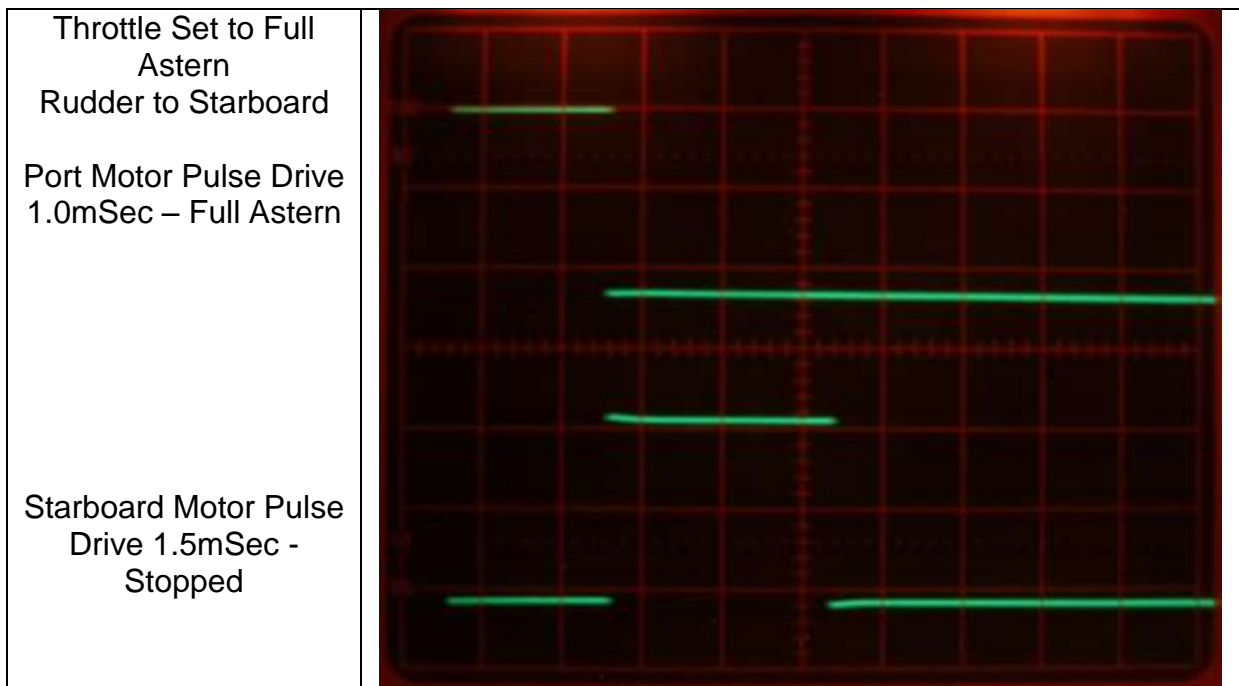

Fig 84

HISTORY OF RADIO AND RADIO CONTROL

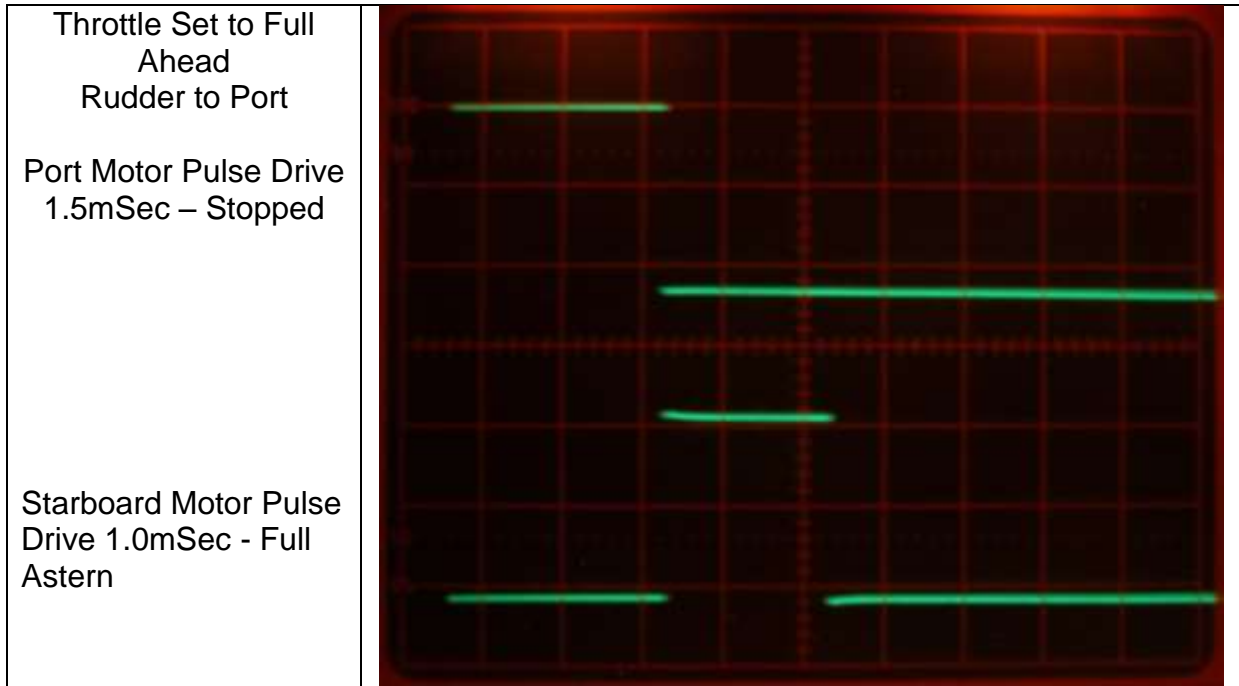

Fig 85

END OF PART 5

THE END