



GLASS DOOR MERCHANDISER

ZLG-430

Single Glass Swing Door Refrigerator



TECHNICAL SPECIFICATIONS

Voltage/Frequency
220 V/50Hz

Refrigerant
R290

Type of Defrost
Automatic

Interior Finish
White

Exterior Finish
Black

Temperature Range °F
33 ~ 40°

Compressor Power (HP)
1/5

Nema Config.
NEMA5-15P



PRODUCT FEATURES



The compressor is mounted in the bottom for better heat evaporation.



Digital temperature controls with LED display for precise adjustment and automatic defrosting system.



Temperature Range 33 ~ 40°F, with auto defrost function, which ensures optimal performance day-in and day-out.



R290 Natural Refrigerant promotes faster cool down and efficient energy consumption.



Interior and canopy LED light with switch on the right side to always show your products at their best



High quality coated stainless adjustable shelves prevent peel and rust.



Anti-fogging tempered glass door helps ensure a crystal clear view of the interior.



HIGH QUALITY & ROBUST DESIGN



Los Angeles | San Francisco | Dallas
Houston | Florida | Chicago | New Jersey



+1(708) 590-9543



info@zuilex.com



www.zuilex.com

DETAILS & SPECIFICATIONS

ZLG-430

Front View

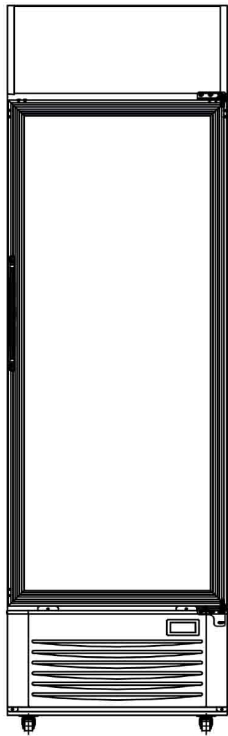

Side View

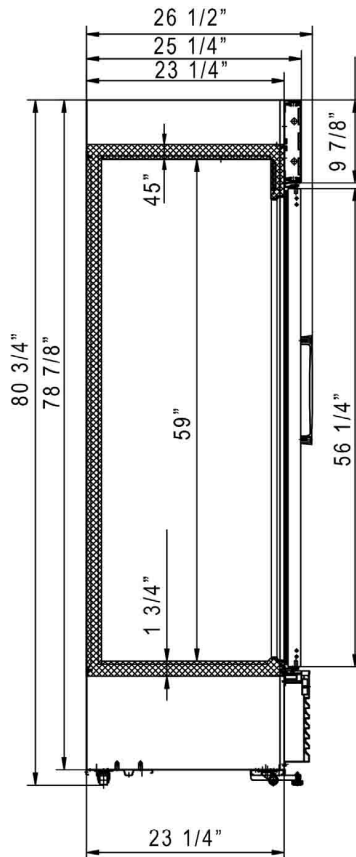

Rated Voltage	220V
Rated Frequency	50Hz
Total Input Power	300W
Total Current	2.9A
Total Capacity	15.2cu ft
Climatic Category	4-5
Protection Type	I
Design Pressure High Side	300 PSIG
Design Pressure Low Side	150 PSIG
Insulation Blowing Gas	C-Pentane
Refrigerant	R290

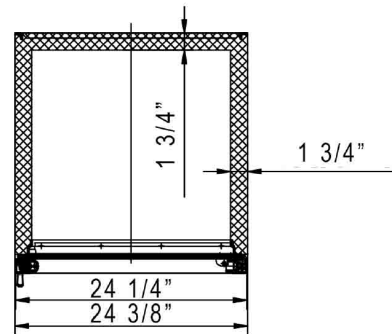

MODEL	EXTERNAL DIMENSION WXDXH (INCHES)	PACKAGING DIMENSION WXDXH (INCHES)	PRODUCT NET WEIGHT	# OF SHELVES	40HQ CONTAINER CERT.
ZLG-430	24 3/8 x 26 1/2 x 80 3/4	25 3/8 x 27 1/2 x 81 3/4	214 lbs	4	51



Los Angeles | San Francisco | Dallas
Houston | Florida | Chicago | New Jersey

+1(708) 590-9543

info@zuilex.com

www.zuilex.com