

# Floor Type High Power Fryer Series BF-9EF



**BF-9EF**



## Product Description

Open PF series floor-standing electric furnace is designed for deep-fried fast-food restaurants

### Standard Features

The FRY-9e/FRY-18e computer board controls the electric fryer. The computer board uses the latest intelligent computer board from Caizhi. It is powerful and can intelligently fry 12 different ingredients at the same time. Multiple parameters can be adjusted separately. It is designed strictly in accordance with international industry standards, with advanced technology and trendy style

It is divided into single-cylinder double-screen and double-cylinder double-screen

The total power is 9/18kW, the total capacity is 5 pounds/28L, and the slot capacity is 12.5-14L. It is especially suitable for high-intensity and high-efficiency occasions such as American fast food. Compared with similar models in the United States, it is a new fryer with a very superior cost performance

### Options & Accessories

- \*Split frypots
- \*Stand-alone spreader cabinet
- \*Frypot cover
- \*Casters
- \*Full basket
- \*Triplet basket
- \*Crisper tray
- \*Sediment tray
- \*Splash shield
- \*Top connecting strip

Specifically designed for high-volume frying and controlled performance PowerFry's proprietary self-standing, swing-up elements and precise controls ensure industry-leading energy efficiency standards and quality.

The thermostat, mounted on the elements, ensures precise temperature readings. The thermostat system minimizes temperature overshoot maximizing oil life.

The large cold zone and forward sloping bottom help collect and remove sediment from the frypot to safeguard oil quality and support routine cleaning. A rear flush feature moves sediment to the front drain valve for easy and thorough removal

### Product Description

Open FRY series floor-standing electric restaurants, convenience stores, such as super market for French fries (cakes, circles) chicken, fish filets, such as professional stoves food. It has high-power heating elements, heating up fast, high efficiency, large capacity, cold design of large diameter pipeline scheduling.

### Features

- 1- Computer control, 12 programs can be set
- 2-Temperature value is more accurate
- 3- Standard of temperature can be switched between °C and °F
- 4- With oil filtration system, makes the oil used for longer timer
- 5- With energy saving mode, it can keep the oil warming and no need too much power

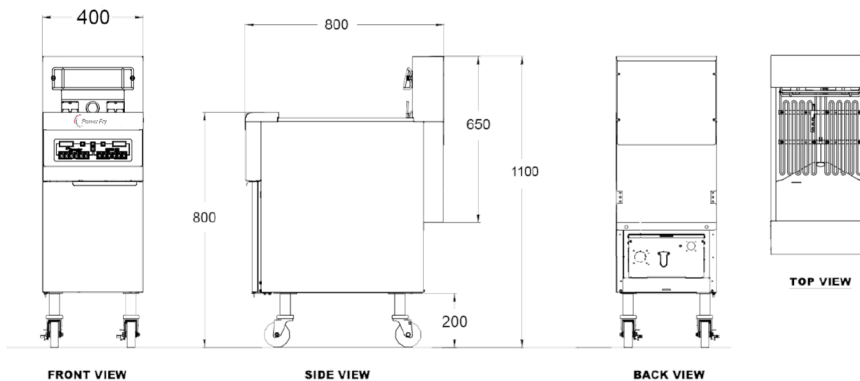
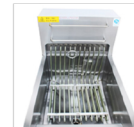
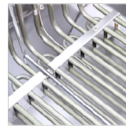

### Electric Open Fryer With Oil Filter System

| Model     | Control Mode | Specification         | Configuration     | Capacity(L) | Dimension(mm) | Package Size(mm) |
|-----------|--------------|-----------------------|-------------------|-------------|---------------|------------------|
| PF-9EF    | Computer     | 220V or 380V/9+0.55KW | 1-tank / 2-basket | 28          | 400*800*1140  | 500*900*1240     |
| PF-9EF-2  | Computer     | 220V or 380V/9+0.55KW | 2-tank / 2-basket | 14+14       | 400*800*1140  | 500*900*1240     |
| PF-18EF   | Computer     | 380V/18+0.55KW        | 1-tank / 2-basket | 28          | 400*800*1140  | 500*900*1240     |
| PF-18F-2  | Computer     | 380V/18+0.55KW        | 2-tank / 2-basket | 14+14       | 400*800*1140  | 500*900*1240     |
| PF-2-9EF  | Computer     | 380V/36+0.55KW        | 2-tank / 4-basket | 28+28       | 400*800*1140  | 500*900*1240     |
| PF-2-18EF | Computer     | 380V/36+0.55KW        | 2-tank / 4-basket | 28+28       | 400*800*1140  | 500*900*1240     |