

F2/13-78G

70 SUPERLOTUS GAS FRYERS

Gas Fryer 13+13 lts - 2 pans cm. 24x35x38h
2 baskets cm. 21x30x12h. 2 sieve and lids for
pan. 2 drip trays with sieves. Production: 20
kg/h (included both Heads end filler strip)



Construction - Fabricated using CrNi 18/10 AISI 304 grade Stainless Steel Scotch-Brite Satin polish Finish, incorporating 2 mm thick worktop, rounded edges, chromed details and rear splash back. Knobs with waterproof grades IPX5. Model - Professional Gas Fryer on cabinet. With single or Double tank to include both basket and lids, tank filter with basket support. Burners with Piezoelectric ignition and pilot light, thermostatic and thermocouple safety valves. Maintenance - All serviceable parts are accessible by the easy removal of front control panel. Fittings - Appliance is supplied with both LPG and Natural Gas conversion jets and adjustable feet. Oil filter drain pan included.



ITALIAN CULINARY ART

The pictures are purely representative. The manufacturer reserves the right to modify the technical data and models without previous notice.

F2/13-78G

70 SUPERLOTUS
GAS FRYERS

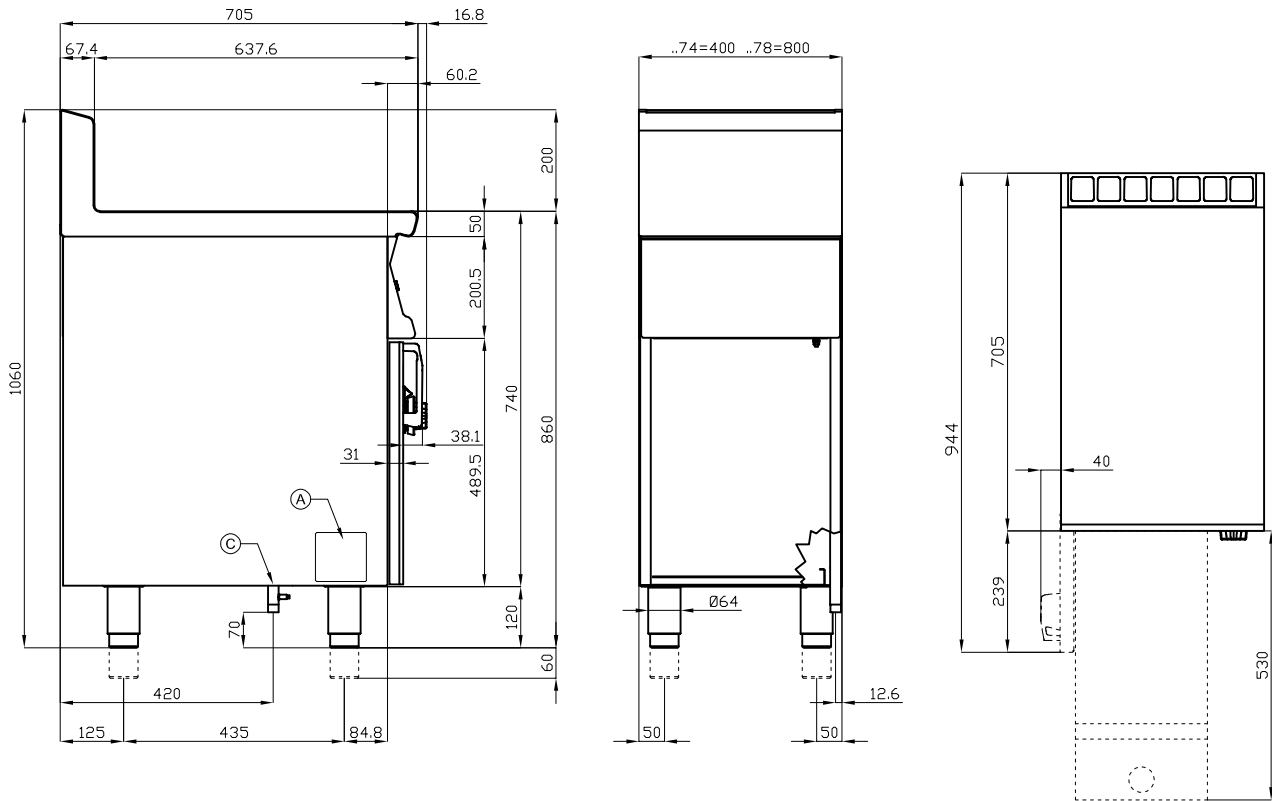

A	Data plate	C	Gas connection	ISO 7-1 1/2" M
---	------------	---	----------------	----------------

MODEL: F2/13-78G
 DIMENSIONS: cm. 80x 70,5x 90h
 GAS POWER: 18,6 kW / 16.000 kcal/h
 GAS TYPE: Natural Gas / LPG



kg: 102
 m³: 0.78
 mm: 830x770x1220

BUY LOTUS BUY ITALY

The pictures are purely representative. The manufacturer reserves the right to modify the technical data and models without previous notice.



LOTUS S.P.A. Via Calmaor, 46
 31020 San Vendemiano(TV) - Italy
 Tel. + 39 0438 778020 / 778468
 Fax + 39 0438 778277
 www.lotuscookers.it - lotus@lotuscookers.it