



## HOPLCNC

### VENTLESS PROFESSIONAL AIR FRYER

#### FUNCTIONAL CHARACTERISTICS

Display	LCD 2,4" IPS
Supply	Electric
Timer	-
Number of motors	1
Motor speeds	10
Max cooking temperature	260°C
Core probe	-
Cooking chamber material	AISI304
Opening door	Left handle
Chimney	30mm with carbon filter
Humidification	Direct injection
Air injection	DryPRO
Self-washing	Yes



## STANDARDS

Certification	CE
---------------	----

## TRAYS

Trays rack	French fries basket + Breaded tray + Tray extractable
------------	--

Max tray load	French fries basket = 2,5kg Breaded tray = 2kg Tray extractable = 3kg
---------------	---

## DIMENSIONS

Oven size with handle WxDxH	736 x 871 x 593 mm
-----------------------------	--------------------

Oven size without handle WxDxH	736 x 804 x 593 mm
--------------------------------	--------------------

Chamber size WxDxH	455 x 320 x 285 mm
--------------------	--------------------

Unit weight	75kg
-------------	------

## PACKAGING

Packaging	Pallet + carton box
-----------	---------------------

Packaging size WxDxH	770 x 930 x 665 mm
----------------------	--------------------

Unit weight with packaging	103kg
----------------------------	-------

Crate packaging size (optional)	770 x 930 x 665 mm
---------------------------------	--------------------

## ELECTRICAL DATA

### HEATERS 9kW 50/60Hz

Power	9.5kW
-------	-------

Frequency	50Hz
-----------	------

Power supply	400V 3~N
--------------	----------

Amperage	15A
----------	-----

Power cord req.	5G1,5
-----------------	-------

## WATER CONNECTION REQUIREMENTS

Humidification Water Inlet	3/4" M Gas threaded
----------------------------	---------------------

Washing Water Inlet	8mm quick fitting
---------------------	-------------------

Water drain	30mm
-------------	------

Max water hardness	5°f
--------------------	-----

Water pressure requirement min-max	150-200 kPa
------------------------------------	-------------

## CONSUMPTION

Humidification Water	-
----------------------	---

Rinse Water @2barG	7,9l
--------------------	------



Short Washing Water @2barG	24,9l
Long Washing Water @2barG	31,1l
Short Washing Detergent *	70g
Long Washing Detergent *	140g

## CONNECTIVITY

USB	USB 2.0
Bluetooth	-
Wi-Fi	Standard
Cloud	Standard

## ACCESSORIES

Oven stand	-
Wheels kit for stand	-
Hood (Air)	-
Hood (Water)	-
Stacking kit	SK58
French fries basket	85GRI00342
Basket support	85GRI00340
French fries extractable basket	85GRI00347
Breaded extractable basket	85GRI00364
Crumbs tray	10VAS00144
Crumbs grid	85GRI00372
Tray extractable	85GRI00370
Basket handle (1pc)	85MNG00036
Basket Handles holder	85SUP00161
Water softner cover	WS10
Water softner 6800l	WS11
Water softner 12000l	WS12
Water pressure adapter	WPA
Water shower kit	S1
Detergent 6kg	DT2
Detergent 10kg	DT4



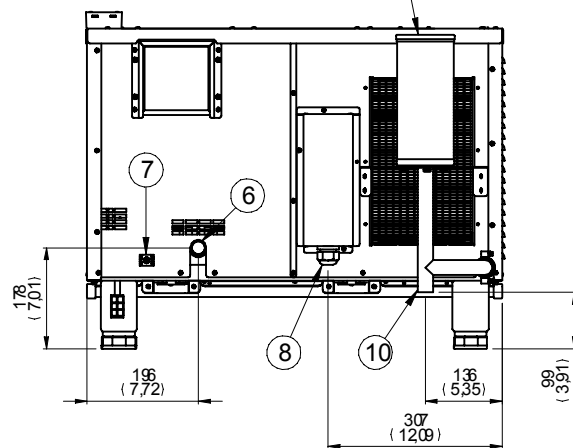
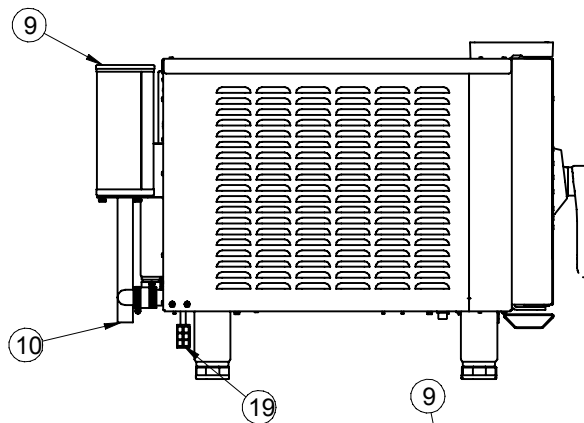
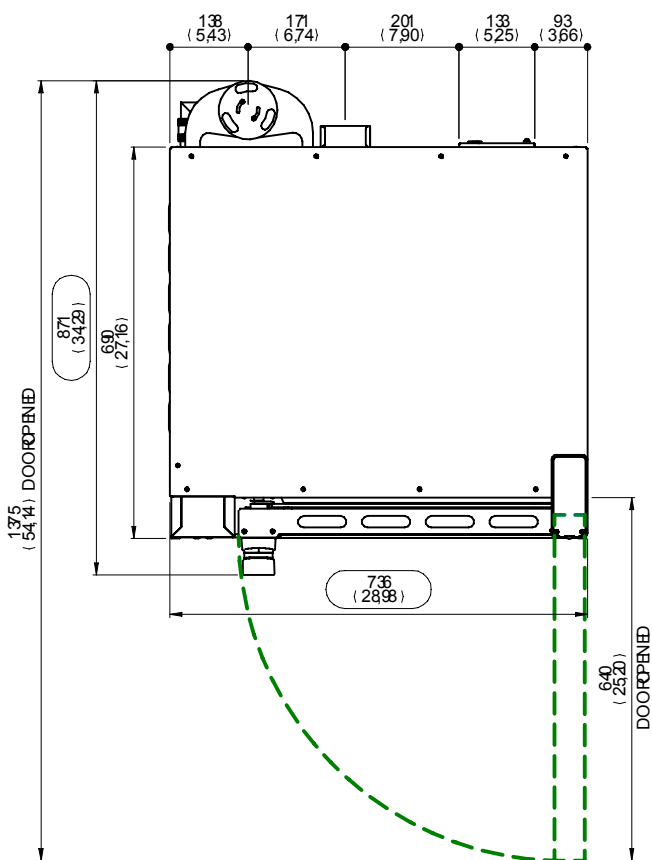
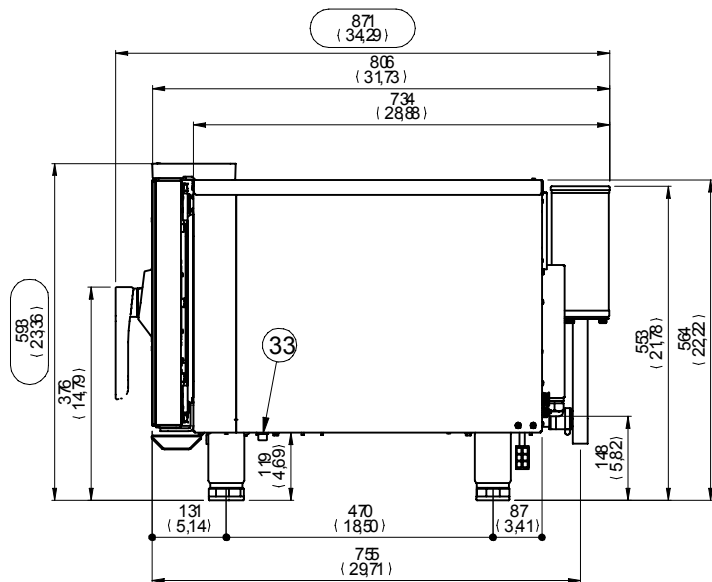
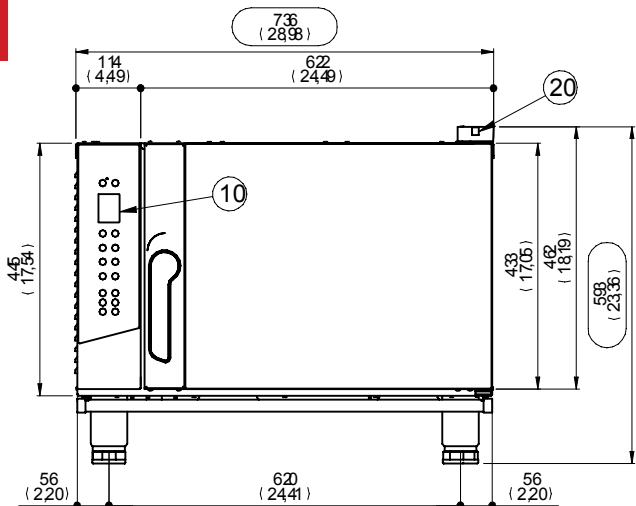

06.	HUMIDIFICATION & WASHING SOLENOID VALVE 3/4" BSP(GAS)
07.	GROUND TERMINAL
08.	COMPRESSION CABLE GLAND
09.	HOT FUMES EXHAUST FILTERING SYSTEM

10.	2,4" DIGITAL CONTROL
13.	DRAIN PIPE Ø30MM
19.	DEGREASING DETERGENT HOSE
20.	USB PORT
33.	SECURITY THERMOSTAT

