

# LEVEL-UP





**Dal 1989 un punto di riferimento nella produzione di forni professionali di qualità made in Italy.**

**Inoxtrend nasce nel 1989 nella Inox Valley italiana e si caratterizza, fin dall'inizio, per l'attenzione rivolta alla specializzazione e alla ricerca continua di soluzioni adatte ad ogni cucina professionale per:**

- Ristoranti
- Hotel
- Gastronomie
- Catene di ristorazione
- Coffee shop
- Bar
- Stazioni di servizio
- Panifici
- Pastifici

**La risposta pronta alle esigenze dei clienti e la cura dei rapporti relazionali hanno permesso la continua crescita dell'azienda e la sua evoluzione.**

Since 1989 a point of reference in the production of made in Italy quality professional ovens.

Inoxtrend was founded in 1989 in the Italian Inox Valley and is characterized, from the very beginning, by the attention paid to specialization and the continuous search for solutions suitable for every professional kitchen in:

- Restaurant
- Hotel
- Gastronomy
- Catering chain
- Coffee shop
- Bar
- Petrol station
- Bakery
- Pastry shop

The prompt response to customer needs and the care of relationships have allowed the company to continue growing and evolving.

# LEVEL-UP IL TUO FEDELE ALLEATO

**La soluzione tecnologica ideale per ricette gastronomiche che liberano la fantasia dello chef, gestendo la cottura di volta in volta, o utilizzando i programmi preimpostati.**

**Strumento multifunzione, con cui cucinare, arrostitire, grigliare, friggere, brasare, raggiungendo perfetti risultati di cottura e un'ottimale organizzazione del lavoro.**

**Il nostro know-how, la continua ricerca dei nostri ingegneri e la collaborazione con ottimi chef ci hanno permesso di sfruttare ogni possibilità offerta dalla tecnologia per metterla a servizio dell'arte culinaria.**

**Level up è il connubio perfetto tra design raffinato e performace di cottura straordinarie.**

## LEVEL-UP YOUR FAITHFUL ALLY

The ideal technological solution for deli dish recipes that unleash the chef's imagination, allowing cooking to be managed differently each time, or using preset programs.

A multifunctional tool, which can be used to cook, roast, bake, grill, fry, braise, achieving perfect results and optimal work organization.

Our know-how, the endless research efforts of our engineers and support from top chefs have allowed us to make the most of every possible technological option to put it at the service of culinary art.

Level-Up is the perfect combination of stylish design and outstanding cooking performance.



# CARATTERISTICHE E VANTAGGI

**Robustezza ed affidabilità sono le caratteristiche essenziali di Level-Up. Il suo design è raffinato, ideale per le cucine a vista, studiato per supportare in modo pratico le attività di tutti i giorni, garantendo la gestione ottimale della brigata e riducendo gli sprechi di cibo.**

## PLUSES AND FEATURES

Sturdy design and reliability are key features of Level-Up. Its sophisticated design, ideal for open-plan kitchens, supports users in carrying out everyday activities, ensuring optimal management of the kitchen team and reducing food waste.

### FUNZIONE DELTA T

La cottura in Delta T cioè basata sul differenziale (delta) di temperatura (T) è una particolare tecnica di cottura che usa una sonda per mantenere costante durante tutto il tempo di cottura la differenza fra temperatura della camera e quella al cuore del prodotto.

La funzione Delta T è configurabile da 1° a 150°C ed è attivabile selezionando la sonda al cuore.

### DELTA T FUNCTION

Delta T cooking, based on temperature (T) differential (delta) settings, is a particular cooking technique that uses a probe to keep the difference between the temperature of the chamber and the core temperature of the food constant for the whole cooking time.

The Delta T function can be configured from 1° to 150°C and can be activated by selecting the core probe.



### BRUCIATORE A GAS PREMISCELATO

Con il sistema premiscelato ad alto rendimento, la combustione di gas e aria è ottimizzata, garantendo la migliore efficienza.

### PREMIXED GAS BURNER

Thanks to a high-performance premixed system, gas and air combustion is optimised, ensuring the best efficiency.



### ILLUMINAZIONE LED

Doppia illuminazione sulla porta e all'interno della camera di cottura, per una perfetta visibilità in ogni angolo della teglia.

### LED ILLUMINATION

Double lighting on the door and inside the cooking chamber - for perfect visibility in every corner of each tray.



**Schermo touch da 7 pollici con interfaccia intuitiva.**  
7-inch touch screen with intuitive interface.



**Temperatura max 260°C, per grigliare o rosolare.**  
Max temperature 260°C, for grilling or browning.



**Programmi per cottura e lavaggio.**  
Cooking & Washing programs.

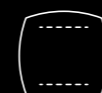

**Modalità dedicata per cotture delicate.**  
Dedicated mode for delicate cooking.

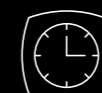

**Timing: da 1 min a 99:59 h, o funzionamento ininterrotto.**  
Timing: 1 min to 99:59 h, or uninterrupted operation.



**Funzionalità di avvio ritardato.**  
Delayed start function.



**Disponibile con preriscaldamento.**  
Available with preheating.



**2 velocità, con ventilazione normale o semistatica.**  
2 speeds, with standard or semi-static ventilation.

# LEVEL-UP

SUPER OVEN



Capacity  
20 levels × GN 1/1

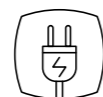

Power (kW)  
38.0



Power supply  
Electric



Voltage (V)  
380-415V 3N

Frequency (Hz)  
50/60



Heating mode  
With steam generation



Controller  
Touch

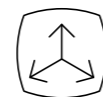

Outside Dimensions (cm)  
L 100 D 100 H 189

# LEVEL-UP

HEAVY-DUTY USE



*\*su richiesta / upon order*



Capacity  
20 levels × GN 1/1, 2/1

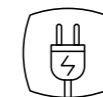

Electric Power (kW)  
30/52



Gas Power (kW)  
29/40



Power supply  
Electric/Gas



Voltage (V)  
220/380-240/415V 1/3N

Frequency (Hz)  
50/60 or 60\*



Heating mode  
With direct steam injection



Controller  
Touch/  
Analogue



Outside Dimensions (cm)  
L 97 D 103/135 H 188

# LEVEL-UP

TOUCH



**8 MODELLI**  
Ad alimentazione elettrica o gas.  
A iniezione diretta di vapore.

**8 MODELS**  
Electric or gas powered.  
Direct steam injection.

DT 107

7 Levels GN 1/1  
L 82 D 90 H 78



DT 111

11 Levels GN 1/1  
L 82 D 90 H 106



DT 207

7 Levels GN 2/1  
L 107 D 102 H 78



DT 211

11 Levels GN 2/1  
L 107 D 102 H 106



*\*su richiesta / upon order*



Capacity  
7-11 levels × GN 1/1



Electric power (kW)  
8.3-23.0



Gas power (kW)  
12.0-23.0



Power supply  
Electric/Gas



Voltage (V)  
220/380-240/415V 1/3N

Frequency (Hz)  
50/60 or 50\*



Heating mode  
With direct steam injection



Controller  
Touch

# LEVEL-UP

ANALOGUE



**8 MODELLI**  
Ad alimentazione elettrica o gas.  
A iniezione diretta di vapore.

**8 MODELS**  
Electric or gas powered.  
Direct steam injection.

CDA 107

7 Levels GN 1/1  
L 80 D 75/78 H 80



CDA 111

11 Levels GN 1/1  
L 80 D 75/78 H 106



CDA 207

7 Levels GN 2/1  
L 105 D 87/90 H 80



CDA 211

11 Levels GN 2/1  
L 107 D 87/90 H 106



\*su richieste / upon order



Capacity  
7-11 levels × GN 1/1, 2/1



Electric power (kW)  
8.3-23.0



Gas power (kW)  
12.0-23.0



Power supply  
Electric/Gas



Voltage (V)  
220/380-240/415V 1/3N

Frequency (Hz)  
50/60 or 50\*



Heating mode  
With direct steam injection



Controller  
Analogue

# SALVA E PROGRAMMA LE TUE RICETTE

## SAVE AND PROGRAM YOUR RECIPIES

Tramite il comodo ed intuitivo touch screen potrai scegliere fra le tante ricette internazionali, testate nei nostri laboratori, o salvare le tue negli oltre 1000 spazi disponibili.

Il software di programmazione ti aiuterà a replicare le ricette ogni volta che lo vorrai, ottenendo lo stesso risultato, oppure a trasferirle dal pannello di controllo in qualsiasi altro sistema SMART, come con il tuo Tablet o Smartphone.

Through the user-friendly, intuitive touch screen you can choose from many international recipes, tested in our laboratories, or upload yours to the over 1000 available slots.

The programming software will help you replicate any recipes whenever you want to obtain identical results, or transfer recipes from the control panel to any other SMART system, such as your tablet or smartphone.



## MULTI RECIPIES

Ricettario diviso per tipologie di portata, come pasta e riso, carne, pollo, pesce, verdure, uova e pasticceria.

Recipe book divided by dish types, such as pasta and rice, meat, chicken, fish, vegetables, eggs and pastries.



## MULTI LEVEL & COOKING

Questa funzione permette di cucinare piatti diversi in contemporanea, suggerendoti l'ordine ed il tempo corretto di inserimento e fuoriuscita della singola teglia.

This function allows you to cook different dishes at the same time, suggesting the right order and the right time to put in/remove from the oven individual trays.



## ALL START

La cottura inizia nello stesso momento per tutti i piatti, il forno avverte quando ciascun piatto è pronto per essere servito.

Cooking starts at the same time for all dishes, and the oven warns the user when each dish is ready to be served.



11	00:24	
10	00:10	
9	—	65°
8	00:24	
7	00:10	
6	—	65°
5	—	50°
4	00:33	
3	00:06	
2	—	
1	00:14	

## ALL END

La cottura finisce nello stesso momento per tutti i piatti, il forno avverte quando ciascun piatto deve essere inserito.

Cooking ends at the same time for all dishes, and the oven warns the user when each dish should be put in.



11	00:24	
10	00:10	
9	—	65°
8	00:24	
7	00:10	
6	—	65°
5	—	50°
4	00:33	
3	00:06	
2	—	
1	00:14	

## MULTI END

La cottura finisce in momenti diversi per ciascun livello. Una volta impostato il Multi Cooking lo puoi salvare e usarlo quando vuoi.

Cooking ends at different times for each level. Once Multi Cooking has been set it can be stored and used at any time.



# CONNETTIVITÀ AL TUO SERVIZIO

## CONNECTIVITY AT YOUR SERVICE

**I forni Level-Up sono dotati di alta tecnologia, che assicura performance e risultati eccellenti. Potrai salvare ed esplorare centinaia di ricette che Level-Up cuocerà in autonomia, riscaldandosi fino a raggiungere la temperatura predefinita. L'app Nube, sfruttando una connessione wi-fi, ti avviserà con una notifica quando il piatto sarà pronto.**

Level-Up ovens are high technology products which ensure excellent performance and results. You will be able to save and explore hundreds of recipes that Level-Up will cook autonomously, heating up until the predefined temperature is reached. Using a wi-fi connection, the Nube app will alert you sending a notification when the dish is ready.



## TECNOLOGIA USB PER AGGIORNARE LE RICETTE

**Grazie alla porta USB puoi rapidamente aggiornare le tue ricette.**

## USB TECHNOLOGY TO UPDATE YOUR RECIPIES

Through the USB port you can quickly update your recipes.



## DIRETTAMENTE DAL FUTURO: NUBE

**Grazie a Nube, Inoxtrend è ancora più vicina a voi. Attraverso una connessione wi-fi, potete creare, modificare e condividere ricette su più apparecchiature; mentre il vostro forno sarà sempre aggiornato e monitorato. Registro HACCP sempre aggiornato, nonché service consigliato e in real time per aiutarvi in ogni passaggio in tempo reale.**

## STRAIGHT FROM THE FUTURE: NUBE

Thanks to Nube, Inoxtrend is even closer to you. Through a wi-fi connection, you can create, edit and share recipes on multiple appliances; while your oven will always be updated and monitored. HACCP register always updated, as well as recommended and real-time service to help you in every step.

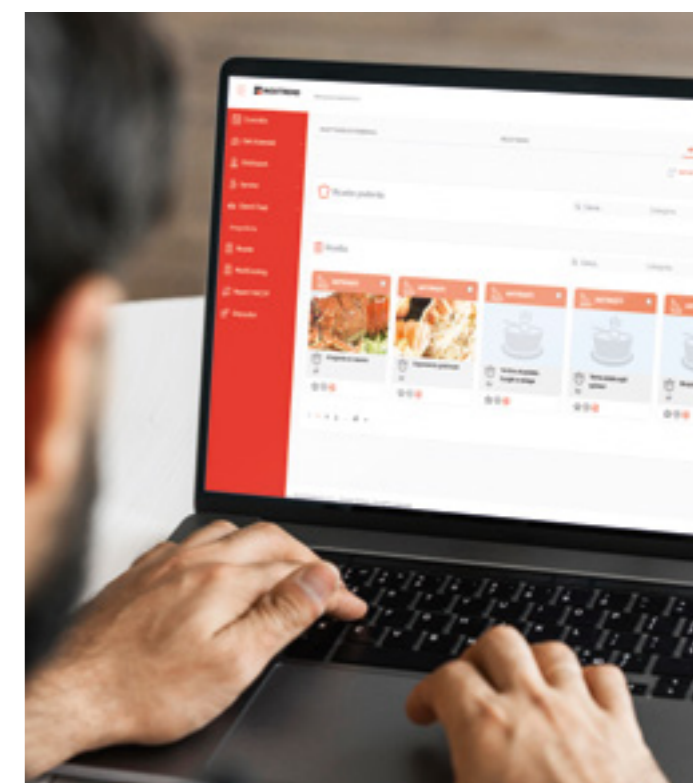

# SOLUZIONI SMART MANIGLIA ERGONOMICA

SMART SOLUTIONS  
ERGONOMIC HANDLE

**Il reparto R&D di Inoxtrend ha studiato la soluzione migliore per una cucina dinamica in modo da garantire la massima comodità durante le concitate ore del servizio: la maniglia ergonomica brevettata, a doppia impugnatura, ti permette di aprire il forno anche con le mani occupate.**

Inoxtrend's R&D team has studied the best solution for a dynamic kitchen in order to guarantee maximum comfort during hectic service time: the patented ergonomic handle, with double grip, allows you to open the oven even with your hands full.



# SOLUZIONI SMART LAVAGGIO

## SMART SOLUTIONS WASHING

**Il sistema di lavaggio automatico appositamente studiato per far risparmiare risorse all'utente finale e per rispettare l'ambiente, vi farà ottenere una perfetta pulizia della camera di cottura indipendentemente dal suo livello di sporco. Potrete scegliere tra 5 programmi disponibili quello più adatto alla vostra necessità.**

The automatic washing system is specially designed to help the end user save resources and respect the environment; it helps to achieve perfect cleaning of the cooking chamber regardless of its level of dirt. You can choose from 5 available programs the one best suited to your needs.

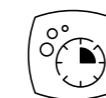
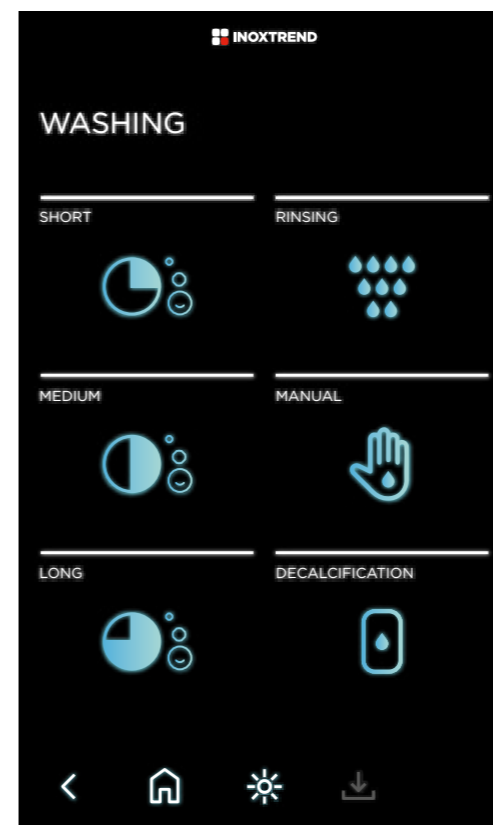

### LAVAGGIO BREVE

**Questo programma è indicato in caso di lavaggio quotidiano del forno e/o di un basso livello di sporco. Nei forni con lavaggio a pastiglie richiede l'uso di 1 pastiglia di detergente.**

### SHORT WASHING

This program is suitable for daily washing of the oven and/or for a low level of dirt. Ovens with tablet washing require the use of 1 detergent tablet.

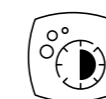

### LAVAGGIO MEDIO

**Questo programma è indicato in caso di lavaggio non molto frequente con un livello medio di sporco. Nei forni con lavaggio a pastiglie richiede l'uso di 2 pastiglie di detergente.**

### MEDIUM WASHING

This program is suitable for infrequent washing with an average level of dirt. Ovens with tablet washing require the use of 2 detergent tablets.

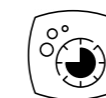

### LAVAGGIO LUNGO

**Questo programma è indicato in caso di lavaggio poco frequente. A seconda della quantità di sporco accumulata potrebbe essere necessario ripetere il ciclo più di una volta. Richiede l'uso di 3 pastiglie di detergente.**

### LONG WASHING

This program is suitable for infrequent washing. Depending on the amount of dirt accumulated, it may be necessary to repeat the cycle more than once. Requires the use of 3 detergent tablets.



### RISCIACQUO

**Questo programma non utilizza nè detergente nè brillantante. Si tratta di una funzione studiata per rimuovere leggeri residui di cibo della cottura precedente.**

### RINSING

This program does not use neither detergent nor rinse aid. This is a function designed to remove light food residues from previous cooking.



### LAVAGGIO MANUALE

**Questo programma è indicato qualora esauriate il detergente fornito da Inxtrend. Selezionando questo programma, il forno vi avviserà quando vaporizzare il detergente da voi scelto all'interno della camera.**

### MANUAL WASHING

This program is recommended if you run out of detergent supplied by Inxtrend. By selecting this program, the oven will notify you when to vaporize the detergent you have chosen inside the chamber.

# OPZIONI E ACCESSORI

## OPTIONS AND ACCESSORIES

### TEGLIA ANTIADERENTE IN LEGA LEGGERA

NON-STICK BAKING TRAY  
IN LIGHT ALLOY

Ideale per cottura di tutti  
i prodotti, riducendo la  
quantità di condimenti  
grassi. Di facile pulizia.

Ideal for cooking all  
products, reducing  
the amount of fatty  
condiments. Easy to clean.

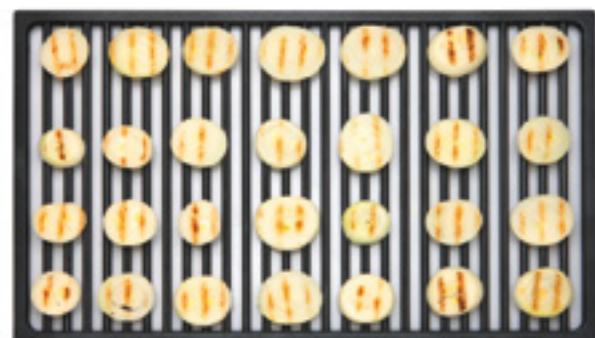

### GRIGLIA ANTIADERENTE

NON-STICK GRILL

Ideale per verdure,  
pesce e carne alla griglia.

Ideal for grilled vegetables,  
fish and meat.

### TEGLIA ANTIADERENTE DOUBLE FACE

DOUBLE-SIDED  
NON-STICK BAKING TRAY

Liscia per cotture  
alla piastra e rigata  
per alla griglia.

Smooth for grilling  
and ribbed for grilling.



### TEGLIA RIGATA ANTIADERENTE

NON-STICK  
LINED TRAY

Ideale per verdure,  
pesce e carne alla griglia.  
La struttura della griglia  
permette di mantenere  
i liquidi di cottura e la sua  
pulizia è molto facile.

Ideal for grilled  
vegetables, fish and  
meat. The structure of  
the grill allows to keep  
the cooking liquids  
and to easily clean it.

### CESTELLO INOX FORATO

WIRE MESH STAINLESS  
STEEL BASKET

Ideale per tutti i tipi  
di frittura e cottura  
al vapore.

Ideal for all types  
of frying and steam  
cooking.



### TEGLIA A 6 INVASI IN ALLUMINIO

6-PAN ALUMINUM  
TRAY

Per cuocere fino a 6  
frittate, uova occhio  
di bue, rosti di verdure.

For cooking up to 6  
omelettes, bull's-eye  
eggs, vegetable rosti.

### TEGLIA PIEGATA SMALTATA

FOLDED ENAMELLED  
TRAY

Ideale per cotture  
prolungate. La finitura  
granito permette una più  
facile pulizia della teglia.

Ideal for prolonged  
cooking. The granite  
finish allows easier  
cleaning of the tray.



**KIT SOVRAPPOSIZIONE**  
STACKING KIT

**SOVRAPPREZZO PER STRUTTURA**  
OVERPRICE FOR ROLL IN RACK

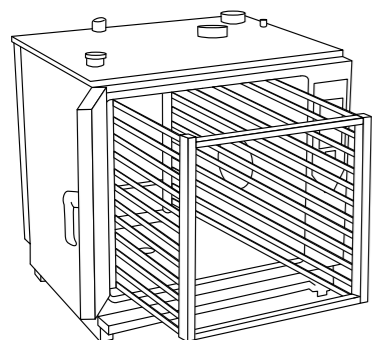

**PORTA INCERNIERATA A DESTRA**  
RIGHT HINGED DOOR

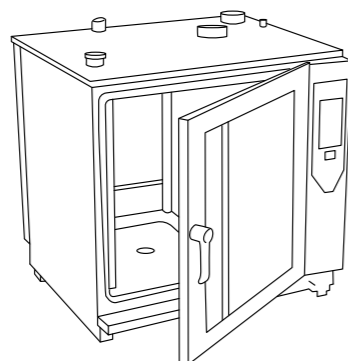

**DOCCIONE**  
HAND SHOWER

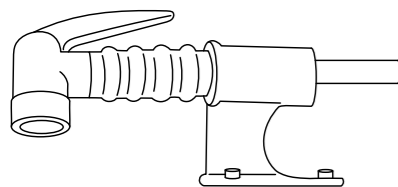

**SONDA AL CUORE**  
CORE PROBE

**SONDA AL CUORE MULTIPUNTO**  
MULTIPOINT CORE PROBE

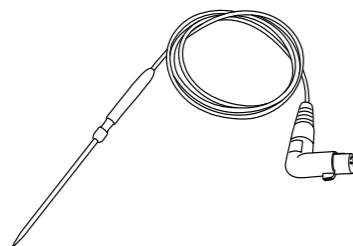

**FILTRO GRASSI**  
FAT FILTER

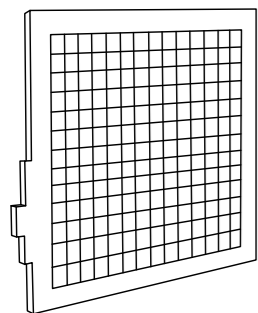

**CAPPA ASPIRAZIONE CON FILTRO**  
SUCTION HOOD

**CAPPA CON CONDENSAZIONE VAPORE**  
SUCTION HOOD WITH STEAM CONDENSATION

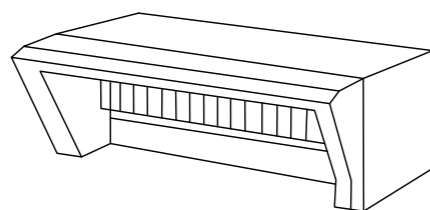

**SUPPORTO APERTO**  
OPEN STAND

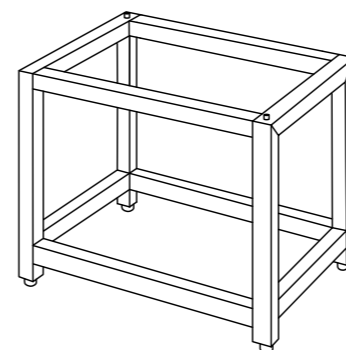

**PORTATEGLIE**  
TRAY SLIDES

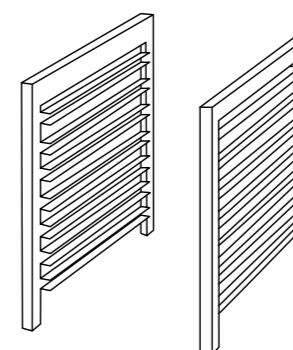

**STRUTTURA PORTATEGLIE ESTRAIBILE**  
ROLL IN RACK

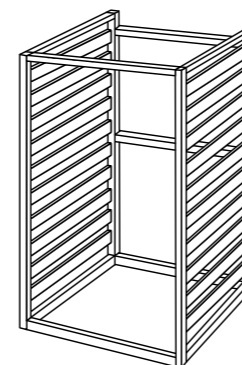

**CARRELLO PER STRUTTURA PORTATEGLIE**  
TROLLEY FOR ROLL IN RACK

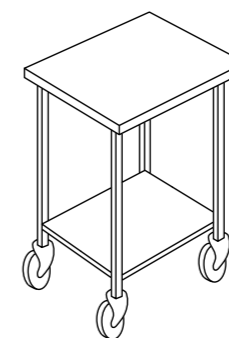

**CARRELLO PORTATEGLIE (20 X 1/1 GN)**  
MOBILE OVEN RACK (20 X 1/1 GN)

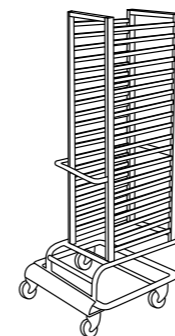

**CARRELLO PORTATEGLIE (20 X 2/1 GN)**  
MOBILE OVEN RACK (20 X 2/1 GN)

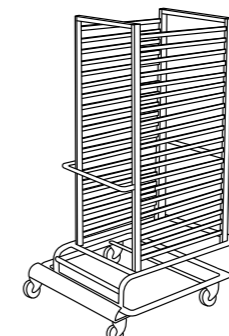

**CARRELLO PORTAPIATTI (52 Ø 31 CM)**  
PLATE RACK TROLLEY (52 Ø 31 CM)

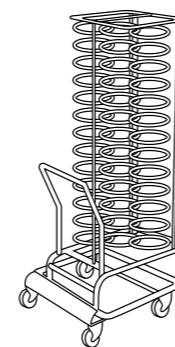

**CARRELLO PORTAPIATTI (104 Ø 31 CM)**  
PLATE RACK TROLLEY (104 Ø 31 CM)

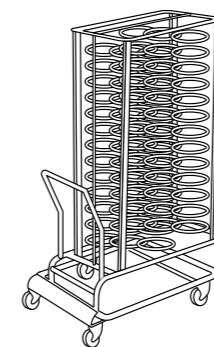

**COPERTA TERMICA**  
HEAT RETAINING HOOD

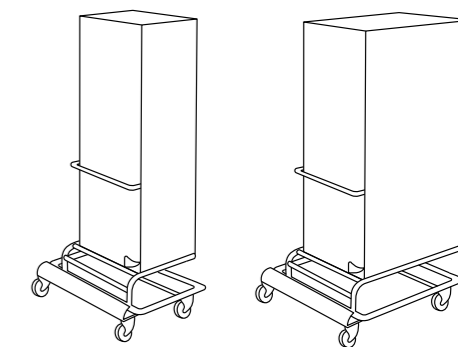

# CUCINARE, ARROSTIRE, GRIGLIARE. COOKING, ROASTING, GRILLING.

I NOSTRI  
PRODOTTI

**LEVEL-UP  
COMPATECH  
FLEXO  
VERSO  
TOGO**

OUR  
PRODUCTS

**LEVEL-UP  
COMPATECH  
FLEXO  
VERSO  
TOGO**

Inoxtrend Srl reserves the right to make use of, necessary modifications at any time to its products, with or without prior notice.

Inoxtrend Srl si riserva il diritto di apportare, in qualsiasi momento, le modifiche utili e necessarie al perfezionamento dei prodotti.

**Inoxtrend S.r.l.**  
Via Serenissima 1,  
31025 Santa Lucia di Piave TV  
Italy

T +39 0438 456990  
info@inoxtrend.com

a **SOMEC** group  
company



**SOMEC SpA (EXM ticker: SOM)** è un gruppo di società specializzate nell'ingegnerizzazione, progettazione e realizzazione di progetti costruttivi chiavi in mano in ambito navale e civile, in tre segmenti di commessa: sistemi ingegnerizzati di architetture navali e facciate civili, sistemi e prodotti di cucine professionali, progettazione e creazione di interior personalizzati. Le società di SOMEC gruppo operano secondo rigorosi standard di accreditamento per posizione finanziaria e scala operativa, e di certificazione per qualità, sicurezza e sostenibilità ESG. SOMEC è qualità costruttiva italiana.

SOMEC SpA (EXM ticker: SOM) consists of a group of companies, specialized in the engineering, design and execution of turnkey naval and civil construction projects, in three project sectors: engineered systems of naval architecture and building façades, professional kitchen systems and products, design and creation of bespoke interiors. SOMEC group companies are credited on Tier 1 Suppliers lists of the main shipyards and building companies in the world and quality, safety and ESG sustainability certified. SOMEC means Italian construction quality.

**/// SOMEC**  
GRUPPO

Level-Up è lo strumento perfetto per chi necessita di elevata produttività ed affidabilità. Il vapore generato tramite boiler garantisce alte prestazioni ed il mantenimento delle caratteristiche organolettiche dei cibi.

Level-Up is the perfect tool for all users who need high productivity and reliability. The steam generated by the boiler guarantees high operating performance and preserves the sensory characteristics of the food.