



## VNX10T7C

BAKERY OVEN 10 TRAYS 600x400 GN 1/1  
7" CAPACITIVE TOUCH CONTROL  
SELF CLEAN INTEGRATED

### FUNCTIONAL CHARACTERISTICS

Display	7" Capacitive IPS touch screen
Supply	Electric
Timer	-
Number of motors	3
Motor speeds	10
Max cooking temperature	280°C
Core probe	3 Points PT1000
Cooking chamber material	AISI304
Opening door	Right handle
Chimney	50mm Motorized valve
Humidification	Direct injection
Air injection	Dry Pro
Version	Standard
Self-washing	Automatic



Feet	55mm (not adjustable)
Duty cycle	7/7 - 10 hours/day
Dotations	-
<b>STANDARDS</b>	
Certification	CE
<b>TRAYS</b>	
Trays rack (standard)	Sheet univ. 10/80mm
Trays rack (optional)	Sheet PA. 10/82mm
Max tray load	4kg
<b>DIMENSIONS</b>	
Oven size with handle WxDxH	788 x 1056 x 1077 mm
Oven size without handle WxDxH	788 x 981 x 1077 mm
Chamber size WxDxH	490 x 638 x 850 mm
Unit weight	149.6kg
<b>PACKAGING</b>	
Packaging	Pallet + carton box
Packaging size WxDxH	830 x 1115 x 1239 mm
Unit weight with cage	167.4kg
<b>ELECTRICAL DATA</b>	
<b>HEATERS 5kW 50/60Hz</b>	
Power	16.4kW
Frequency	50/60Hz
Power supply	380-415V 3N~
Amperage	27.6A
Power cord req.	5G1.5
<b>HEATERS 5kW 50/60Hz</b>	
Power	16.4kW
Frequency	50/60Hz
Power supply	220-240V 1N~
Amperage	71A
Power cord req.	3G16
<b>WATER CONNECTION REQUIREMENTS</b>	
Humidification Water Inlet	3/4" GAS
Washing Water Inlet	3/4" GAS
Water drain	30mm



Max water hardness	5°f
Water pressure requirement min-max	150-200kPa
<b>CONSUMPTION</b>	
Humidification Water	10,8 l/h max consumption
Rinse Water @2barG	7,9l
Short Washing Water @2barG	24,9l
Long Washing Water @2barG	31,1l
Short Washing Detergent *	80g
Long Washing Detergent *	160g
<b>CONNECTIVITY</b>	
USB	USB 2.0
Bluetooth	-
Wi-Fi	Yes
Cloud	Yes
<b>ACCESSORIES</b>	
Self clean system kit	-
Oven stand	TAVNXH6900X - TAVNXH6900U TAVNXH69D1U
Wheels kit for stand	R100 H+76mm
Hood (Air)	-
Hood (Water)	-
Hood (Air/Water)	POVNXTWF1
External Core probe	CP5 (020SON0007)
Sous vide probe	CP4 (020SON0010)
Proofer	CA7912M0 - MH - DH
Stacking kit for 2 ovens	85KIT00181
Heat shield	-
Siphon kit	85KIT00182
Smoker	SMK02
Water softner cover	WS10
Water softner 6800l	WS11
Water softner 12000l	WS12
Water pressure adapter	WPA
Water shower kit	S1
Detergent 6kg	DT2
Detergent 10kg	DT4



◆ Standard   ◇ Optional   - Not available

TYPE OF COOKINGS	
Convection cooking	30°C - 260°C / 86°F - 500°F
Combi cooking	30°C - 230°C / 86°F - 446°F
Steaming cooking	30°C - 130°C / 86°F - 266°F
Static cooking	-
Delta T cooking	5°C - 115°C Δ / 41 °F - 239 °F Δ
Core probe cooking	◆
Sous vide cooking	◆
Low temperature cooking	◆
DISPLAY AND CONNECTIVITY	
Type of display	5" CAPACITIVE IPS TOUCH SCREEN
Multi-language display	◆
Unit set F° or C°	◆
Venix cloud	◆
Wi-fi	◆
Ethernet port	◆
Web server	◆
Usb port	◆
SETTINGS	
Infinity time set	◆
Chimney set	MOTORIZED
Fan speed set	10
Dehumidification set	◆
Humidity set	0-100%
Preheat set	AUTOMATIC
RECIPE COOKING	
User recipes book	400
Factory recipes book	INCLUDED
Cooking cycles	10
Recipes with name and picture	◆
Fast recipe selection buttons	◆
SPECIAL CYCLE	
Multi-level mix ALL IN	◆
Multi-level mix ALL OUT	◆
Food regeneration	◆
Overnight cooking	◆
Overnight self clean	◆
Cook & hold	◆



Multi-timer	◆
Routine program	◆
Proofing	◆
Fast Cooling	◆
Automatic washing system / Rinse	◆
Fast start	◆
Recipe scheduling	◆
Holding / Mass production	◆

#### TECHNICAL FEATURES

Cooking chamber material	AISI 304
Second core probe	◇
Insertion of the trays	IN DEPTH
Fast loading Pro	◇
Glass door	TRIPLE
Easy clean internal glass	◆
High performance thermal insulation	◆
Break drop nebulizer	◆
Lightning	LED ON THE DOOR
Direct injection humidification	◆
Boiler humidification	-
Opening door	NOT REVERSIBLE (RIGHT HANDLE)
Reversing fan	◆
Heavy duty reversing fan	◆
Phase cut speed control	-
Inverter speed control	◆



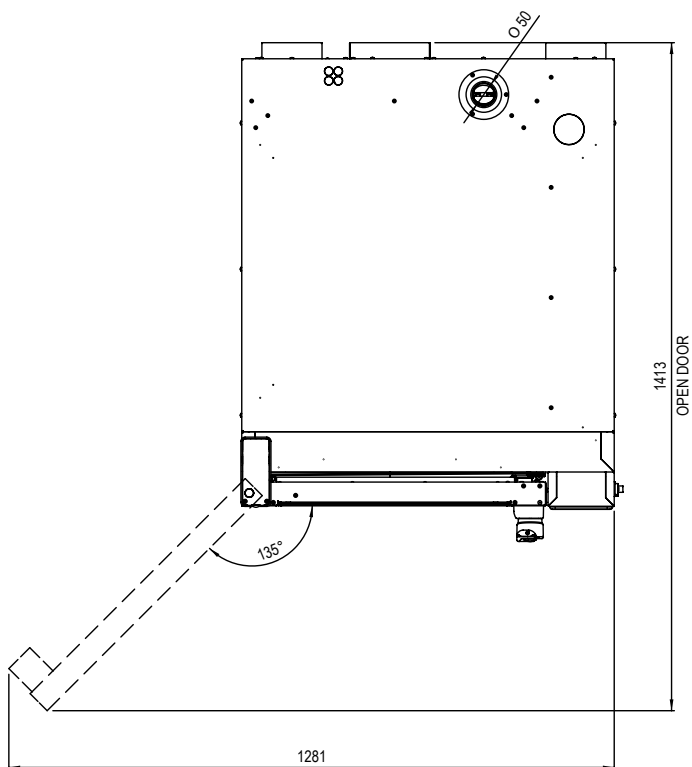
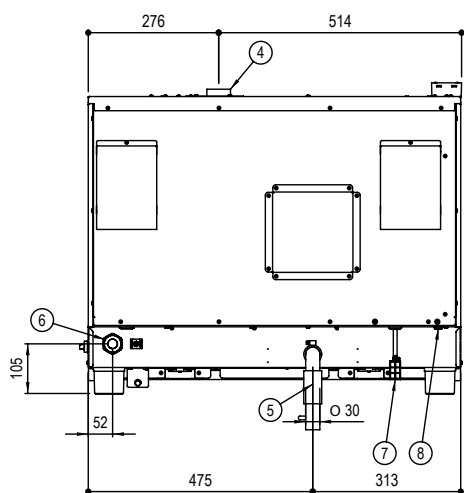
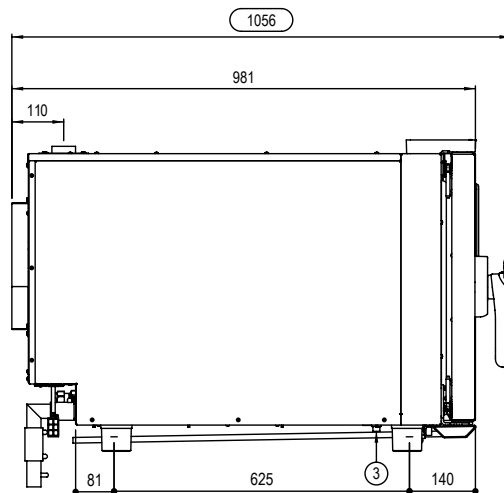
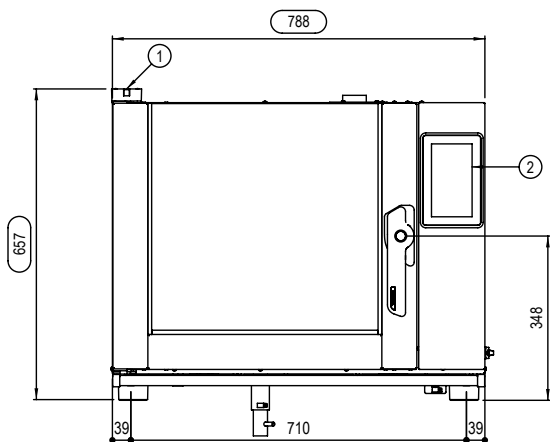

1.	USB CONNECTION
2.	TOUCH CONTROL
3.	SAFETY THERMOSTAT
4.	HOT VAPOUR CHIMNEY Ø50MM

5.	DRAIN PIPE Ø30MM
6.	POWER CORD
7.	DETERGENT INLET
8.	WATER IN-LET

