



# CHEST FREEZER

## WD-500Y



### **i** TECHNICAL SPECIFICATIONS

|                       |           |
|-----------------------|-----------|
| Voltage/Frequency     | 220V/50Hz |
| Refrigerant           | R290      |
| Type of Defrost       | Automatic |
| Interior Finish       | White     |
| Interior Finish       | White     |
| Temperature Range °F  | -8 ~ 0 °F |
| Compressor Power (HP) | 3/8       |
| Nema Config.          | NEMA5-15P |



### PRODUCT FEATURES

- Fan assisted condenser & copper evaporator.
- Temperatures in the cabinet range from -8 to 0 degrees Fahrenheit.
- R290 Natural Refrigerant promotes faster cool down and efficient energy consumption.
- Digital controller and LED temperature display.
- Interior LED light with switch.
- Low-E treated curved glass sliding lids to enhance better cooling.
- Anti-fogging tempered glass helps ensure a crystal clear view of the interior.
- Basket included.
- Bumper bars protection in the front of the unit to prevent impacts and support excessive usage.
- 4" casters with lock for easy mobility.



### HIGH QUALITY STAINLESS STEEL & ROBUST DESIGN



Los Angeles | San Francisco | Dallas  
Houston | Florida | Chicago | New Jersey

+1(708) 590-9543  
 info@zuilex.com  
 www.zuilex.com

# DETAILS & SPECIFICATIONS

## CHEST FREEZER WD-500Y

Front View

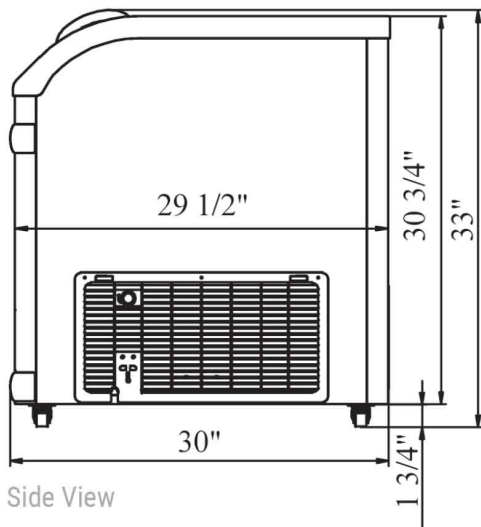
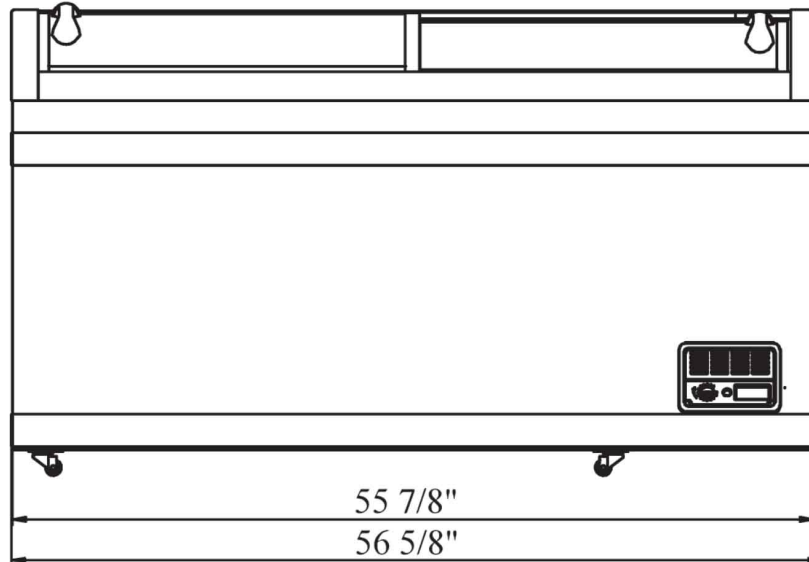

### MODEL WD-500Y

|                           |               |
|---------------------------|---------------|
| Basket Size               | 11 x 21.5 x 6 |
| Rated Voltage             | 220 V         |
| Rated Frequency           | 50Hz          |
| Total Input Power         | 250W          |
| Total Current             | 2.4A          |
| Total Capacity            | 17.66 cu ft   |
| Climatic Category         | 4-5           |
| Protection Type           | I             |
| Design Pressure High Side | 300 PSIG      |
| Design Pressure Low Side  | 150 PSIG      |
| Insulation Blowing Gas    | C-Pentane     |
| Refrigerant               | R290          |

| MODEL   | EXTERNAL DIMENSION<br>WXDXH (INCHES) | PACKAGING DIMENSION<br>WXDXH (INCHES) | PRODUCT NET<br>WEIGHT | # OF<br>BASKETS | 40HQ<br>CONTAINER CERT. |
|---------|--------------------------------------|---------------------------------------|-----------------------|-----------------|-------------------------|
| WD-500Y | 56 1/8 x 29 5/8 x 33 1/8             | 58 1/8 x 31 5/8 x 34 5/8              | 214 lbs               | 4               | 64                      |



Los Angeles | San Francisco | Dallas  
Houston | Florida | Chicago | New Jersey

+1(708) 590-9543

info@zuilex.com

www.zuilex.com