



# CHEF BASE

## ZCB52



**PREMIUM WARRANTY**

### PRODUCT FEATURES

- Digital temperature control features a digital display to make monitoring interior temperatures a breeze. This unit also comes with an auto-defrost function.
- Foamed-in-place insulation keeps the interior cold and adds structural strength.
- Stainless steel Interior with rounded corner for easy cleaning. Meet and exceed sanitation standards.
- Durable and high weight bearing rails for drawers.
- Heavy-duty 4" casters with brakes are included providing the unit with convenient mobility, making cleaning and servicing a breeze! Just roll the unit away from the wall.
- Ergonomic and modern recess door handles.
- Removable Drawer Gaskets, each drawer gasket is removable for easy cleaning and maintenance.

### TECHNICAL SPECIFICATIONS

Voltage/Frequency **220V/50HZ**  
 Refrigerant **R290/2.29oz**  
 Type of Defrost **Automatic**  
 Interior Material **304/201 Stainless Steel**  
 Exterior Material **304/201 Stainless Steel**  
 Total Current **2.088A**  
 Climatic Category **4-5**  
 Nema Config. **NEMA5-15P**  
 Compressor Power (HP) **1/5**

TEMPERATURE RANGE (F°)	EXTERNAL DIMENSION WXD XH (INCHES)	PACKAGING DIMENSION WXD XH (INCHES)	PRODUCT NET WEIGHT	DRAWERS	40 HQ CONTAINER CERTIFICATION
33~38°F	52 1/2x32 1/4"x26 5/8"	54 1/8"x34 1/4"x29 1/8"	242 lbs	2	63

### HIGH QUALITY STAINLESS STEEL & ROBUST DESIGN



Los Angeles | San Francisco | Dallas  
 Houston | Florida | Chicago | New Jersey

+1(708) 590-9543  
 info@zuilex.com  
 www.zuilex.com

# DETAILS & SPECIFICATIONS

## ZCB52

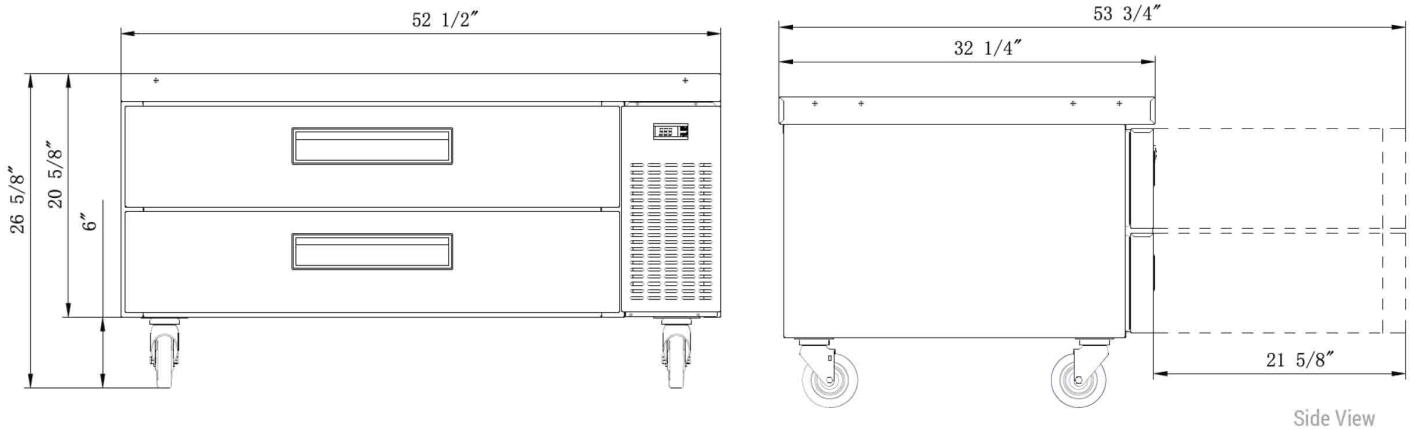

Side View

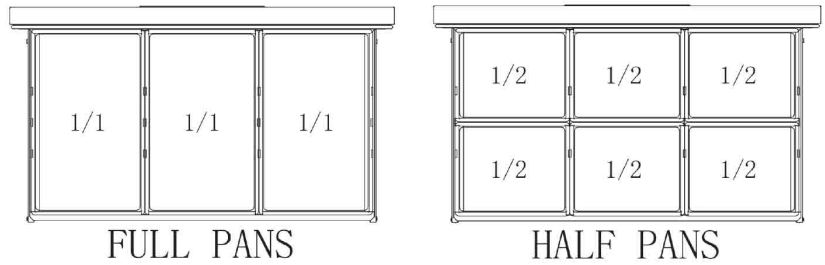

FULL PANS

HALF PANS

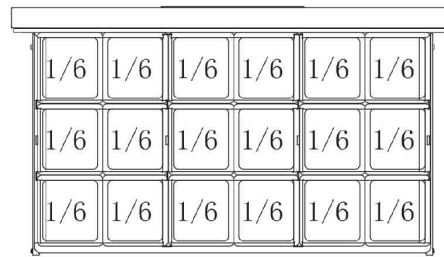

SIXTH PANS

Pan Layout

Rated Voltage	220 V
Rated Frequency	50 Hz
Total Input Power	200W
Total Current	2.088A
Climatic Category	4-5
Protection Type	I
Design Pressure High Side	300 PIG
Design Pressure Low Side	150 PIG
Insulation Blowing Gas	C-Pentane
Net Weight	242 lbs
Nema Config.	NEMA5-15P
Temperature Range	33~38°F
Heating Power	236.9W
40 HQ Container Certification	63
Refrigerant	R290/2.29oz
1/6 Pan Count	18
Compressor Power (HP)	1/5



Los Angeles | San Francisco | Dallas  
Houston | Florida | Chicago | New Jersey

+1(708) 590-9543

info@zuilex.com

www.zuilex.com