



Item # _____
 Qty # _____
 Model # _____
 Project # _____



CHARBROILER

ZCCB24



Cast Iron Waste and Oil Drain



Charboiler Knobs



Cast Iron Waste and Oil Drain

Radiant Burner

Radiant Burner Cover



PRODUCT DESCRIPTION

- + Stainless steel exterior and interior.
- + Double wall sides with stainless steel cabinet.
- 🔥 35,000 BTU Burners per 12" section with standby pilots.
- 🕒 Independent manual controls every 12".
- ❄️ "Cool-to-the-touch" front s/s edge.
- 🔧 Each Char Broiler shipped standard Natural gas, LP conversion kit included.
- 📏 Adjustable stainless steel legs, non-skid feet.
- 🗑️ Easy to remove full width crumb tray.



HIGH QUALITY STAINLESS STEEL & ROBUST DESIGN

* All measures are presented in Inches

CHARBROILER MODEL	DIMENSION		
	Width	Depth	Height
ZCCB24	24 in	28 3/4 in	15 3/8 in



Los Angeles | San Francisco | Dallas
 Houston | Florida | Chicago | New Jersey

+1(708) 590-9543
 info@zuilex.com
 www.zuilex.com

DETAILS & SPECIFICATIONS

CHARBROILER ZCCB24

Front View

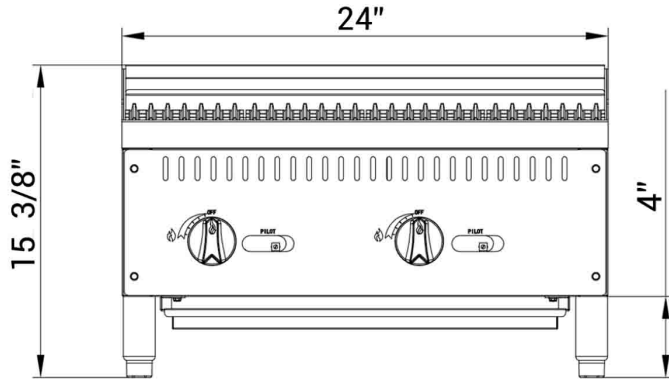

DCCB24

GAS SOURCE	NG/Propane
WORK AREA	23.86x20.47in
BURNER	2 count
SINGLE BURNER	35000 BTU/H
COMBINED	70000 BTU/H
GAS PRESSURE	NG: 4 "WC Propane: 10 "WC
NOZZEL	NG: 34# Propane: 49#
CONTAINER FITMENT	250

Top View

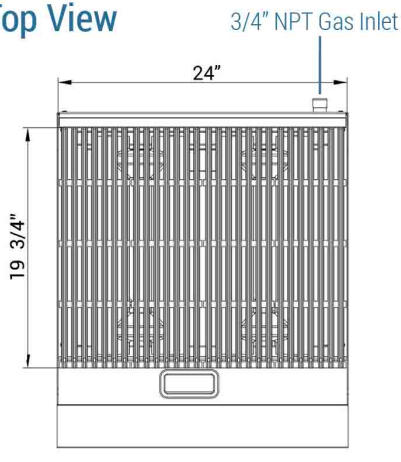

Racks

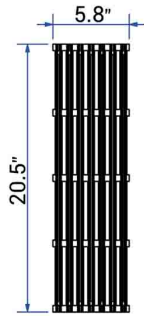

Equipped with 4 racks

Side View

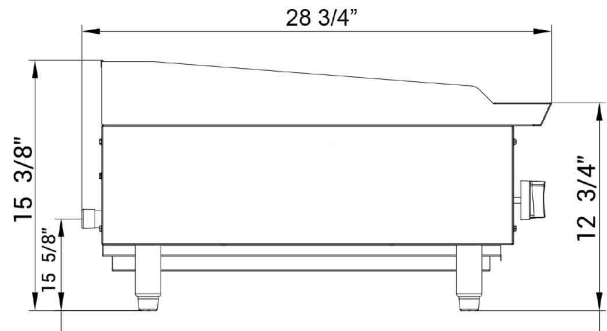

Model	Packaging Dimensions (inches)			Net Weight (lbs)	Ship Weight (lbs)
	W	D	H		
ZCCB24	26 1/8"	32 5/8"	20 1/2"	132.28	154.32



Los Angeles | San Francisco | Dallas
Houston | Florida | Chicago | New Jersey

+1(708) 590-9543

info@zuilex.com

www.zuilex.com