



CHEST FREEZER

ZWD-500Y



TECHNICAL SPECIFICATIONS

Voltage/Frequency	220V/50Hz
Refrigerant	R290
Type of Defrost	Automatic
Interior Finish	White
Interior Finish	White
Temperature Range °F	-8 ~ 0 °F
Compressor Power (HP)	3/8
Nema Config.	NEMA5-15P



PRODUCT FEATURES

- Fan assisted condenser & copper evaporator.
- Temperatures in the cabinet range from -8 to 0 degrees Fahrenheit.
- R290 Natural Refrigerant promotes faster cool down and efficient energy consumption.
- Digital controller and LED temperature display.
- Interior LED light with switch.
- Low-E treated curved glass sliding lids to enhance better cooling.
- Anti-fogging tempered glass helps ensure a crystal clear view of the interior.
- Basket included.
- Bumper bars protection in the front of the unit to prevent impacts and support excessive usage.
- 4" casters with lock for easy mobility.



HIGH QUALITY STAINLESS STEEL & ROBUST DESIGN



Los Angeles | San Francisco | Dallas
Houston | Florida | Chicago | New Jersey

+1(708) 590-9543

info@zuilex.com

www.zuilex.com

DETAILS & SPECIFICATIONS

CHEST FREEZER ZWD-500Y

Front View

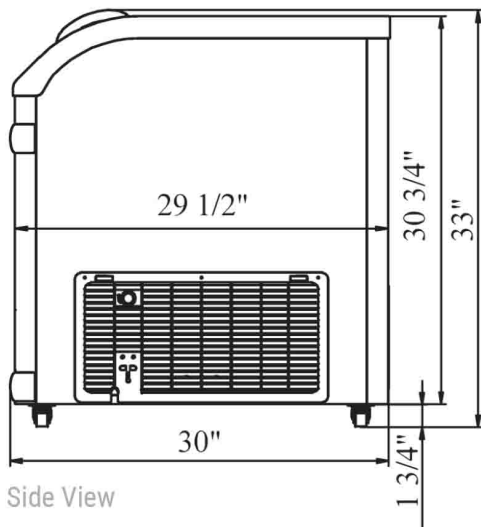
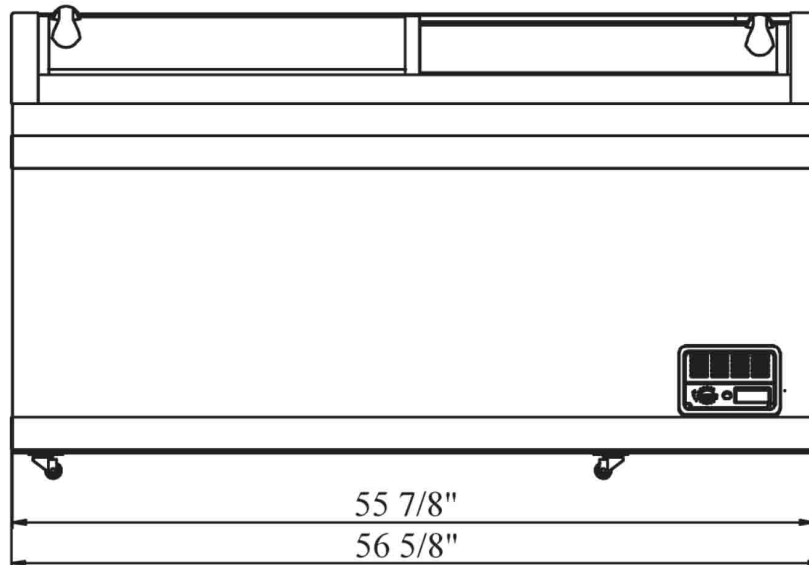

Basket Size	11 x 21.5 x 6
Rated Voltage	220 V
Rated Frequency	50Hz
Total Input Power	250W
Total Current	2.4A
Total Capacity	17.66 cu ft
Climatic Category	4-5
Protection Type	I
Design Pressure High Side	300 PSIG
Design Pressure Low Side	150 PSIG
Insulation Blowing Gas	C-Pentane
Refrigerant	R290

MODEL	EXTERNAL DIMENSION WXDXH (INCHES)	PACKAGING DIMENSION WXDXH (INCHES)	PRODUCT NET WEIGHT	# OF BASKETS	40HQ CONTAINER CERT.
ZWD-500Y	56 1/8 x 29 5/8 x 33 1/8	58 1/8 x 31 5/8 x 34 5/8	214 lbs	4	64



Los Angeles | San Francisco | Dallas
Houston | Florida | Chicago | New Jersey

+1(708) 590-9543

info@zuilex.com

www.zuilex.com