

# WORKING MANUAL FOR VFFS PACKAGING MACHINE AM019- AM020 OMRON EDITION



2020

## Contents

1. INSTALLATION .....	4
<b>1.1 Requirements</b> .....	4
<b>1.2 Placement</b> .....	4
<b>1.3 Grounding</b> .....	4
<b>1.4 Connecting the machine</b> .....	4
2. SAFETY INSTRUCTIONS.....	5
<b>2.1 Who is allowed to operate with the machine?</b> .....	5
<b>2.2 Physical harm</b> .....	5
<b>2.3 Working under the following conditions is strictly prohibited:</b> .....	5
<b>2.4 Additional safety requirements:</b> .....	6
<b>2.5 Safety during film changing:</b> .....	6
3. PACKAGING MACHINE OVERVIEW .....	7
<b>3.1 Front panel overview</b> .....	7
<b>3.2 Back panel overview</b> .....	8
<b>3.3 HMI work panel overview</b> .....	9
4. WORKING WITH THE PACKAGING MACHINE.....	10
<b>4.1 Loading of the packaging film</b> .....	10
4.1.1 Turning ON the packaging machine:.....	10
4.1.2 Film loading.....	11
4.1.3 Forming the “sleeve” around the tube .....	15
<b>4.2 Setting our first RECIPE</b> .....	24
4.2.1. <b>RECIPES</b> menu tree overview.....	24
4.2.2. Editing a RECIPE .....	24
4.2.3. <b>RECIPE PARAMETERS</b> .....	25
4.2.4. <b>QUICK ACCESS MENUS</b> .....	29
4.2.5. <b>EXTERNAL DEVICES</b> .....	30
<b>4.3 MANUAL MODE</b> .....	32
<b>4.3.1 Entering the manual mode</b> .....	32
<b>4.3.2 Manual mode commands</b> .....	32
<b>4.4 SYSTEM SETUP</b> .....	34
<b>4.4.1 Entering the system parameters</b> .....	34
<b>4.4.2 System parameters</b> .....	34
<b>4.5 Starting the packaging machine</b> .....	38
<b>4.5 Startup checklist</b> .....	42
5. WORKING WITH THE DOSING DEVICE .....	42

<b>5.1</b>	<b>Step conveyor type dosing device setup .....</b>	<b>42</b>
<b>6.</b>	<b>WORKING WITH A LABEL APPLICATOR .....</b>	<b>44</b>
<b>6.1</b>	<b>Parameters .....</b>	<b>44</b>
<b>6.2</b>	<b>Label loading schema .....</b>	<b>45</b>

## 1. INSTALLATION

### 1.1 Requirements

- surrounding temperature 15 - 30°C
- humidity in the operating area 35 – 65%
- power supply 220V±10%, 50Hz
- compressed air 4,5 bar, 25l/min; dried and clean air

### 1.2 Placement

Place the machine on a horizontal, stable and flat space.

The machine has to be placed on a spot, where the working process would not be affected by vibrations, dust and other similar effects, which would prevent its normal operation.

Considering the easy operation of the machine and its maintenance, enough free space should be provided around it.

### 1.3 Grounding

Ground the machine. Operating with an ungrounded machine is not allowed.

### 1.4 Connecting the machine

- connect the power supply; (check image 1)



**16A 5-pin industrial plug**

- connect the compressed air;



**8mm external diameter hose**

## **2. SAFETY INSTRUCTIONS**

### **2.1 Who is allowed to operate with the machine?**

For working with the VFFS machine are only allowed persons who are:

- age 18 or above;
- passed all the necessary medical examinations;
- passed all of the mandatory briefings and instructions on the work place;

### **2.2 Physical harm**

Before start working with the VFFS machine, the machine operator should get acquainted with all of the machine modules and parts, which may cause any physical harm and could bear risk for his overall health.

The potential harmful parts of the VFFS machine are marked with the necessary pictograms. Some of the harms that may occur are:

- pinching (drawing belts or rolls);
- burning (soldering elements);
- smashing (sealing jaws);
- cutting (knife);

### **2.3 Working under the following conditions is strictly prohibited:**

- Working with a faulty machine is NOT allowed!!!
- If any damage or indistinctive noises are observed, the work with the machine should stop IMMEDIATELY. If this happen, inform the authorized personnel immediately;
- Working with an opened electrical panel is not allowed. All of the electrical maintenance is done ONLY by an authorized personnel;

- Working with an opened protection covers is not allowed;
- The VFFS machine is designed for packaging food products in polypropylene bags. Any other application of the machine may be considered dangerous and inappropriate;
- Any mechanical adjustments and technical maintenance are not allowed when the machine is on. Turn of the machine first;
- If any tearing, film gathering or sticking occurs due the forming process, STOP the machine before making any adjustments and corrections;
- The access to the spaces around the forming collar, soldering elements, cutting knife, the electrical panel and the dosing device, is STRICTLY forbidden when the machine is working;

#### **2.4 Additional safety requirements:**

- Any waste and spilled product around the machine is not allowed. The space around the machine should be absolutely dry, clean and should be enough to provide easy operation with the equipment;
- A waste disposal container should be placed near the machine so that all of the wasted film to be collected in;
- All of the maintenance operations like knife changing, rollers cleaning and all of the mechanical adjustments are done ONLY by technical personnel and ONLY on a fully stopped and turned off machine. The technical personnel should wait at least 15 minutes after the machine is turned off, in order to allow all of the heating elements to cool down;

#### **2.5 Safety during film changing:**

- During the film changing, the operator should follow all of the safety precautions mentioned above;
- In case, of which any of the instructions above is impaired, and a dangerous situation occurs, the machine operator should press the emergency button at once to stop the machine. If there is any limb caught in-between the sealing jaws, the machine operator should push one of the yellow buttons for manual control of the sealing mechanism, in order to release it;
- Taking off the ready bags at the machine's exit with bare hands is strictly forbidden. You should wait for the bag to fall on the ground. If any empty bags or pieces of film, stick to the soldering elements, the machine operator should turn off the machine, before cleaning it;
- Taking off the ready bags at the machine's exit with bare hands is strictly forbidden. You should wait for the bag to fall on the ground. If any empty bags or pieces of film, stick to the soldering elements, the machine operator should turn off the machine, before cleaning it;
- Any actions from the machine operator, which are not according to the ones mentioned in the current instruction, are considered dangerous and insufficient, and the machine manufacturer bears no responsibility for them;

### 3. PACKAGING MACHINE OVERVIEW

#### 3.1 Front panel overview

- 1 **Colorful touch HMI**
- 2 **START** button- starts the packaging machine
- 3 **STOP** button- stops the packaging machine
- 4 **EMMERGENCY STOP**- stops the packaging machine in case of emergency situation
- 5 **RESET** button- resets the safety relay in case of alarm, error or fault
- 6 **PULLING BELT PRESSURE INDICATOR**- shows the current pressure of the pulling belts
- 7 **PULLING BELT PRESSURE VALVE**- regulates the required pressure of the pulling belts
- 8 **GUSSETED BAG ON/OFF SWITCH (if present)**- turns ON or OFF the gusseted bag forming system
- 9 **MODE switch**- chooses the required mode.
  - Switch to WORKING when packaging with the machine;
  - Switch to MANUAL when you want to use the machine in MANUAL MODE (for setup, film loading and testing)
- 10 **NITROGEN switch (if present)**- chooses the nitrogen injection mode
  - STOP- nitrogen is not spread in the bag;
  - CONSTANT- nitrogen is spread constantly in the bag (recommended for high speed packaging);
  - INTERMITTENT- nitrogen is spread right before closing of the bag (recommended for slow/medium packaging speed)

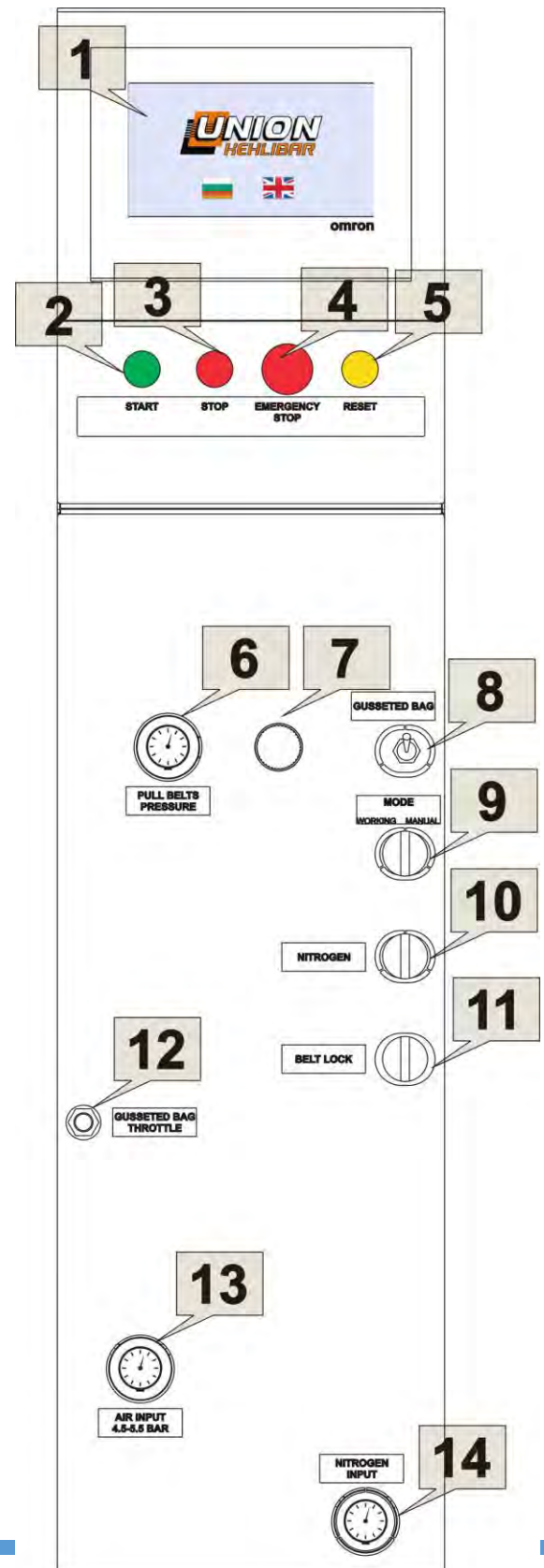



- 11 BELT LOCK switch-** activates the belt grip of the pulling mechanism. If the belt lock is not activated, film pulling will not occur.  
The BELT LOCK should be deactivated when changing the forming collar or loading the packaging film
- 12 GUSSETED BAG THROTTLE-** regulates the speed of the air cylinders, used for the gusseted bag module.
- 13 COMPRESSED AIR PRESSURE INDICATOR-** shows the current pressure of the compressed air, entering in the machine. The value should be between 4.5-5 BAR.
- 14 NITROGEN PRESSURE INDICATOR-** shows the current pressure of the nitrogen system. Increasing the pressure will increase the nitrogen consumption and vice-versa.

### 3.2 Back panel overview

- 1 PHOTOCELL INPUT**
- 2 DOSING SYSTEM (STEP CONVEYOR) INPUT**
- 3 LABEL APPLICATOR COMMUNICATION INPUT**
- 4 LABEL APPLICATOR POWER INPUT**
- 5 FILM CASSETE INPUT**
- 6 POWER ON/OFF**
- 7 220V INPUT**
- 8 AIR BRAKE CONTROL SWITCH**





### 3.3 HMI work panel overview

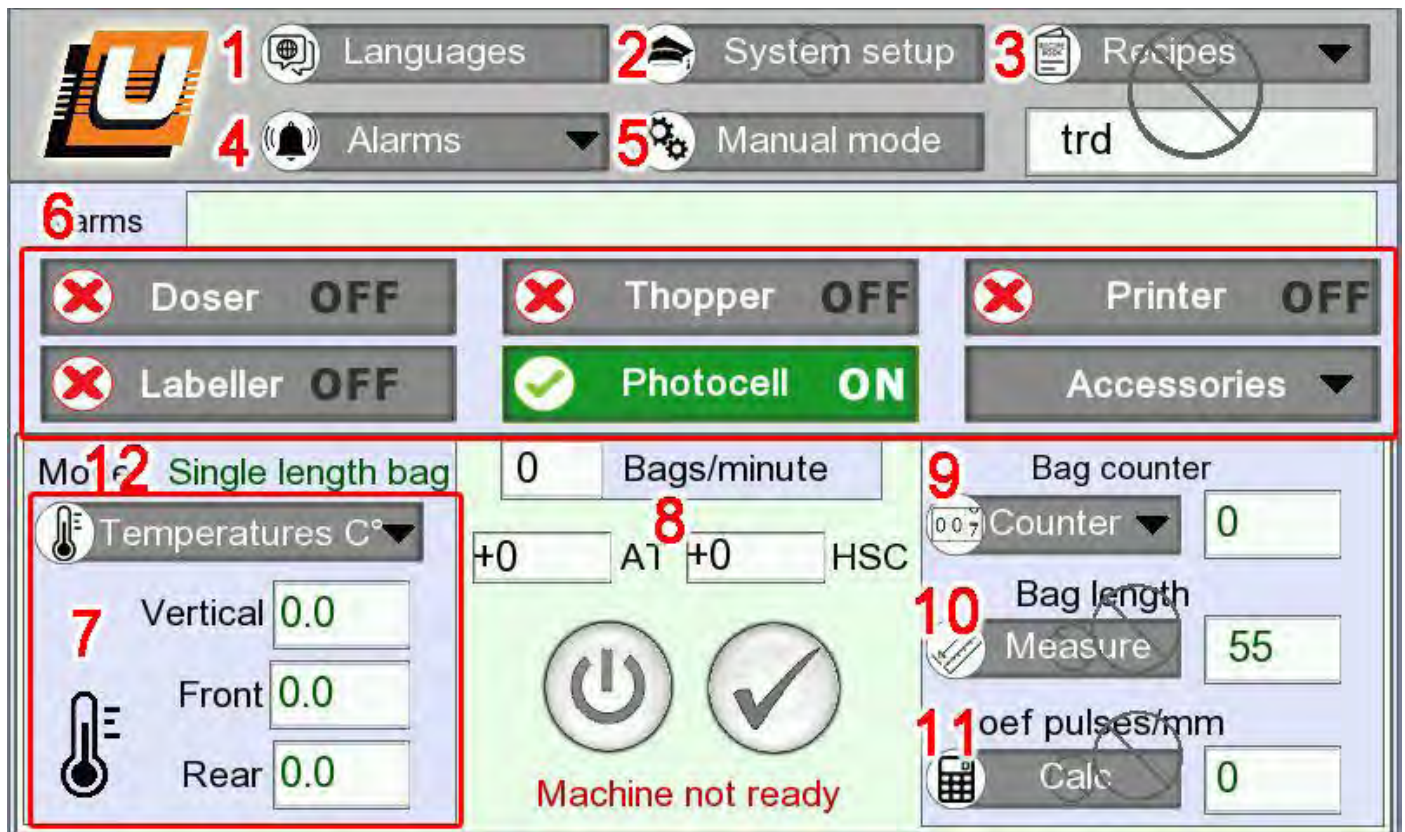

- 1 **LANGUAGES**- from this menu you can switch the current operation language
- 2 **SYSTEM SETUP**- enters the system parameter
- 3 **RECIPES**- enters in the recipe selection and setup menu
- 4 **ALARMS** it shows the current alarms
- 5 **MANUAL MODE**- enters into manual working mode
- 6 **EXTERNAL DEVICES CONTROL**
- 7 **TEMPERATURE CONTROL**- quick access to the temperature setup
- 8 **STATISTICAL INFORMATION** – bags/minute, Auto tuning correction, HSC – current encoder value
- 9 **BAG COUNTER CONTROL** –sets the bag number after which the machine will stop automatically
- 10 **BAG LENGTH MEASURE (active for photocell mode only)** – used to measure the bag length
- 11 **COEF PULSES/mm** – pulls 2 bags on high speed and calculates the mm to servo pulse ration
- 12 **Mode** – single length bag or double length bag (the machine pulls one length, stops for sealing, pulls another one and finally closes the bag. Used when the target bag length is bigger than the vertical sealer)

## 4. WORKING WITH THE PACKAGING MACHINE

### 4.1 Loading of the packaging film

#### 4.1.1 Turning ON the packaging machine:

Turn on the packaging machine from the red switch, situated on the back panel of the machine:



You need to wait at least 10-15 minutes in order to allow the heaters to reach the set temperature. When the machine is turned on, the following Main Menu will be visualized on the screen.



Push the ENABLE button  , to set the machine READY for work.

#### 4.1.2 Film loading

**NOTICE:** During film loading, use the MANUAL MODE switch (front panel). In this mode, the safety relay is bypassed and protective covers could be open for film loading procedure. You cannot start the machine in this mode but use machine manual control only.

In order to put a new film roll, or to change rolls you need to keep the following steps:

1. Release the **AIR BRAKE** by putting the switch to **MANUAL** position



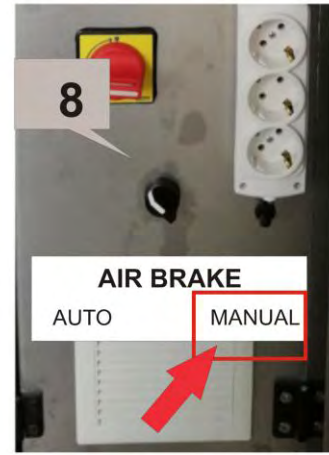

## 2. Remove the film roll shaft



## 3. Change the film roll

Unscrew the handle



Tap the handle with your palm, until the indicator reaches it's far left position



Extract the old roll and put the new one on it's place



**Center** the new roll on the shaft.





Tighten back the handle and return the shaft on its place

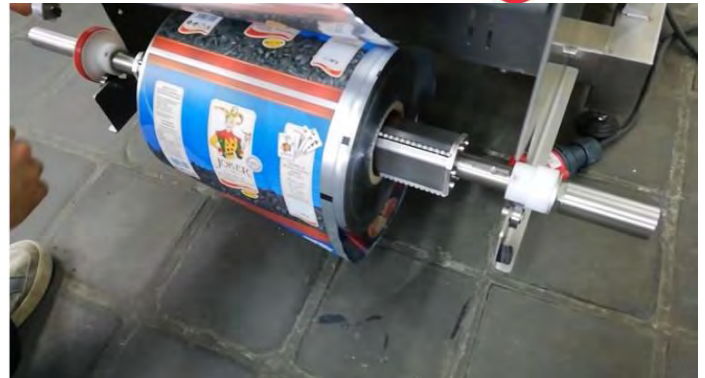

4. Activate back the **AIR BRAKE** by putting the switch to **AUTO** position

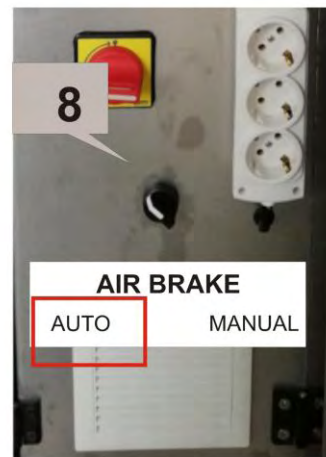

5. Load the packaging film according to the schematic below.

**NOTE:** The packaging film should move smoothly on the shafts. For this reason, the shafts should be maintained always clean, without any dust or stains on them. The improper maintenance may lead to slippage and difficult film movement, which will imminent cause a negative impact on the machine's overall performance.

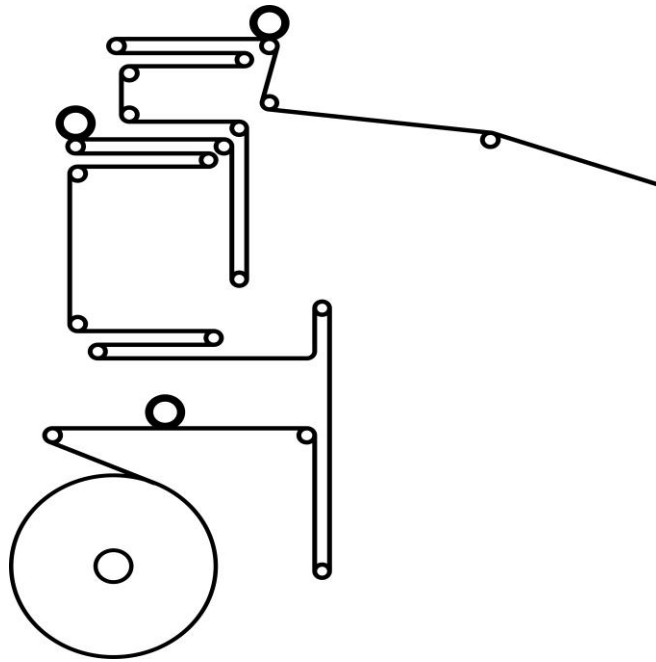

The schematic above is an example. The actual schematic may differ, according to the additional devices, installed on the machine. The actual schematic is illustrated on the machine itself.

#### 4.1.3 Forming the “sleeve” around the tube

After the film is loaded on the machine, you should pass it through the **bag-forming collar**. In order to do that, it’s highly recommended to cut the end of the packaging film and form a long and narrow strip, as shown on the image. This way the passing should be quite easier.





After the packaging film is successfully loaded and passed through the collar, you need to form the sleeve over the tube and prepare the machine for packaging.

Pull the film manually, following the procedure:

1. Open the protective covers.
2. Open the vertical heater.



3. Release the pulling belts.



4. Pull the film sleeve manually, until it reaches the pulling belts area.



5. Lock the pulling belts

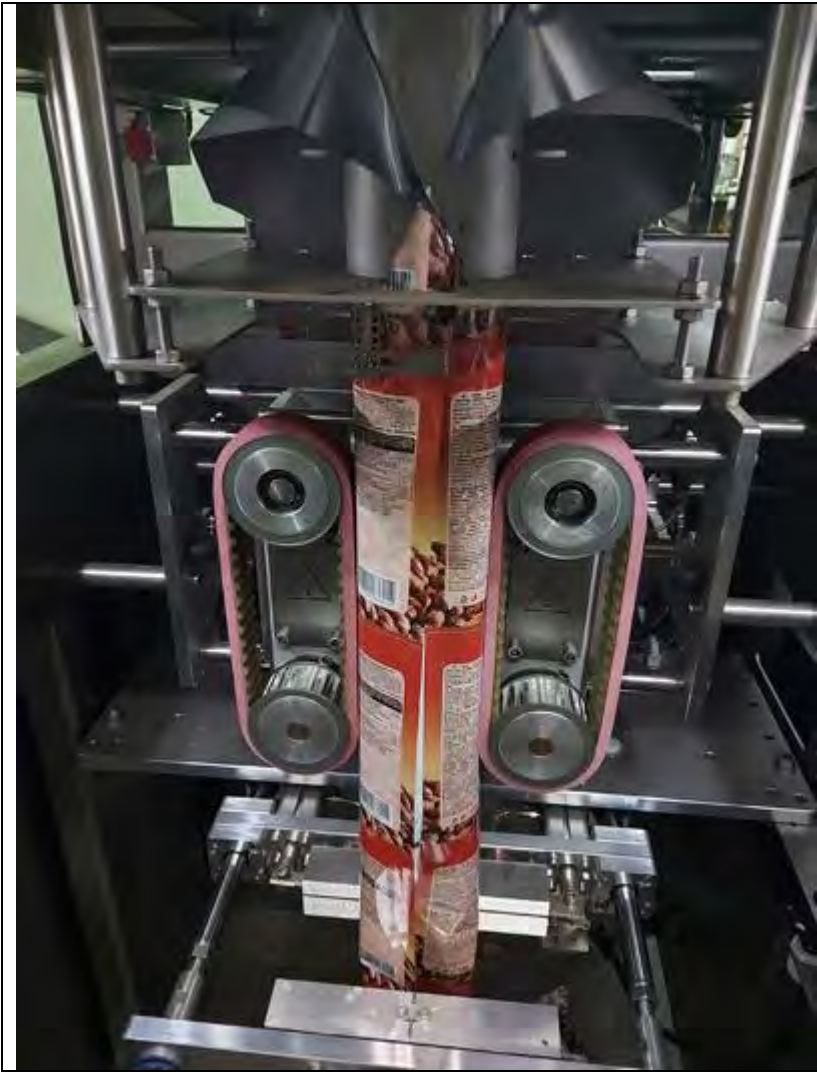



6. Enter in manual mode

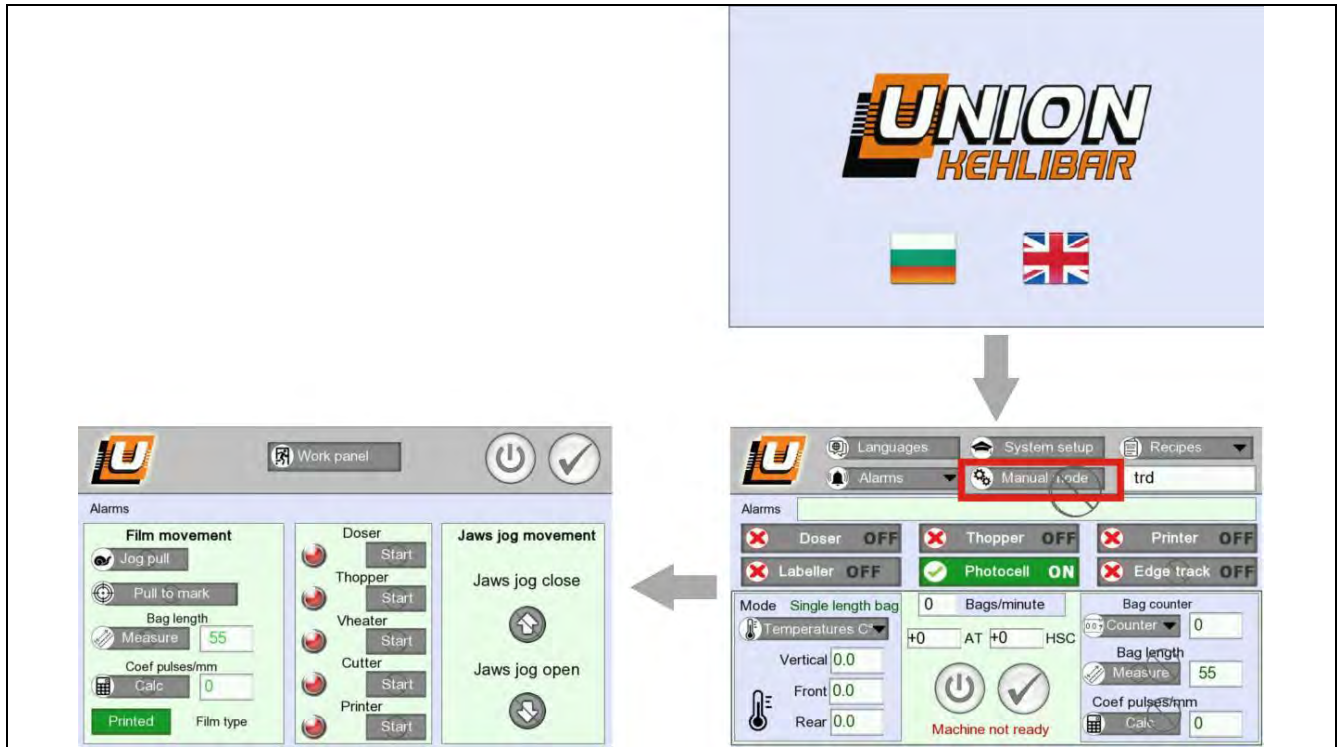

OR

7. Push the **Jog pull** in order to pull the packaging film.



8. Center the packaging film according to the collar.

The packaging film should be even on the both sides of the collar

If both sides are not even, you will need to readjust the cassette left or right.

If the film is more on the left side, you need to move the cassette to the right and vise-versa.

When performing this adjustment, be sure that the guides are pulled to the side and are not affecting the packaging film movement. We will put them back on the film, when we are sure that it is centered.

After we move the cassette in the required direction, we need to pull the packaging film manually and see if the film is getting centered according to the collar.



We perform the procedure until the film is finally centered.

9. Adjust the vertical overlapping by hand according to vertical seam type



Notice: if the packaging film contains LDPE, fin type seal only could be used!!!

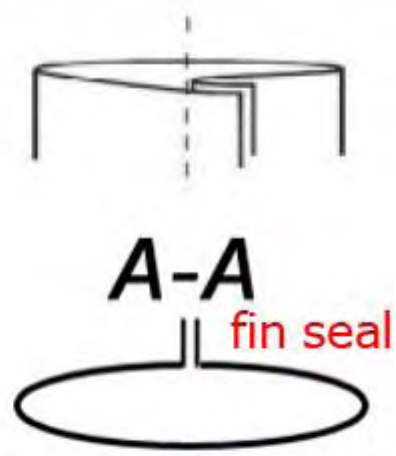

10. Put back the vertical heater.
11. Close the protective covers.

## 4.2 Setting our first RECIPE

### 4.2.1. RECIPES menu tree overview

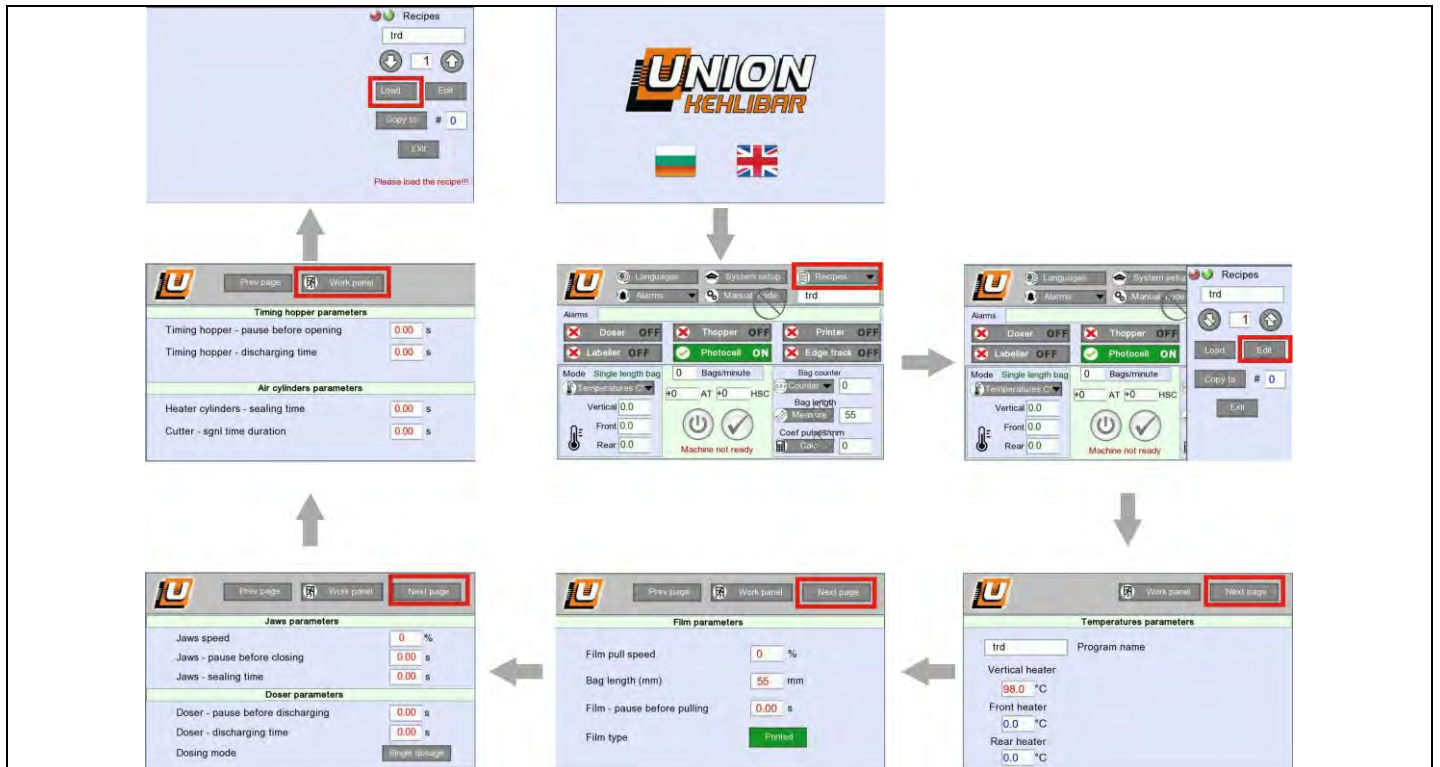

### 4.2.2. Editing a RECIPE

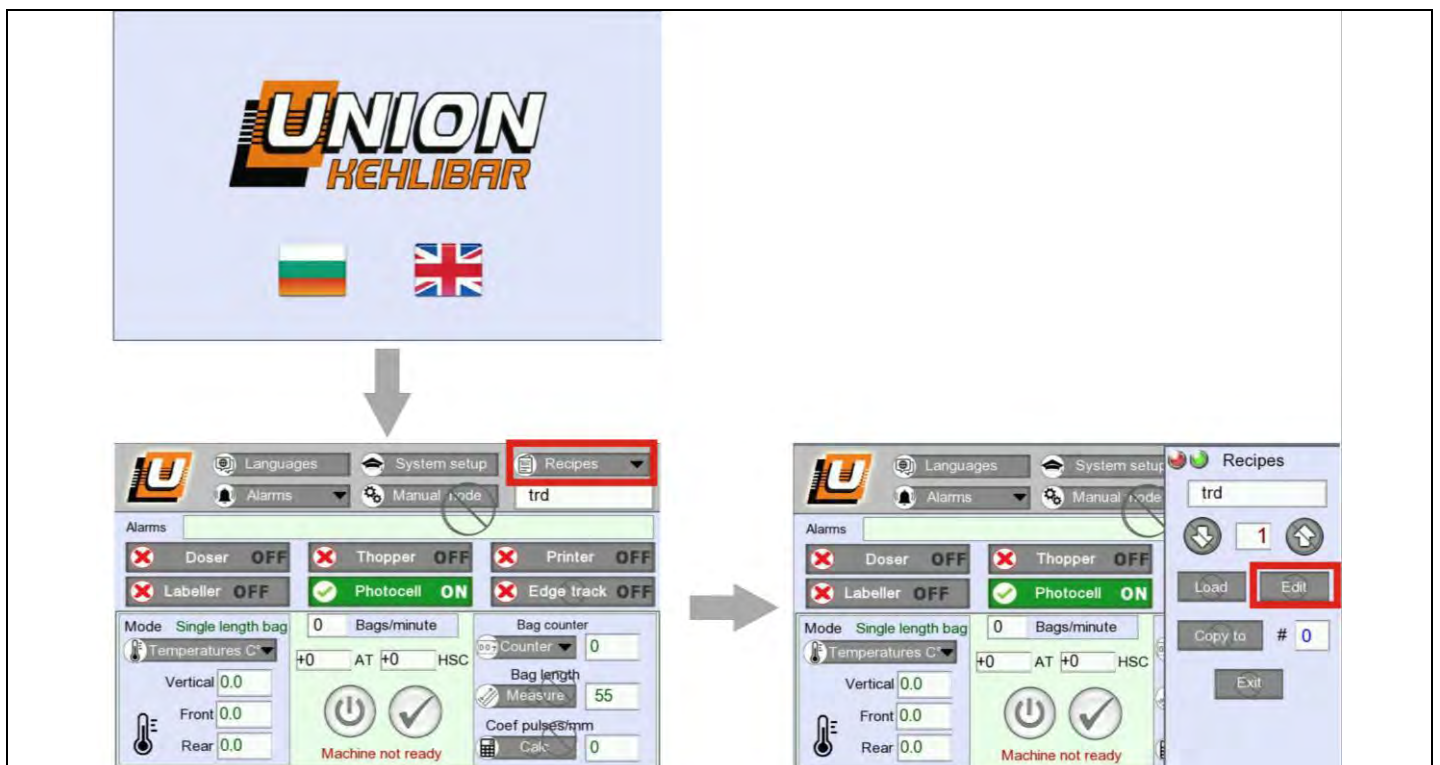

1. Push the **RECIPES** button on the MAIN SCREEN





2. Select a the recipe, which you want to edit, using the **UP/DOWN** arrows
3. After you select the required recipe, press the **EDIT** button to enter the setup menu

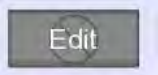

#### 4.2.3. RECIPE PARAMETERS

##### 1. Temperatures parameters

The screenshot shows the 'Temperatures parameters' setup menu. At the top left is the Union Helibrar logo. To its right are 'Work panel' and 'Next page' buttons. Below this is a title bar with 'Temperatures parameters'. The main area contains a text field for 'Program name' with the value 'trd'. Below it are three temperature fields: 'Vertical heater' with a value of 98.0 °C, 'Front heater' with a value of 0.0 °C, and 'Rear heater' with a value of 0.0 °C.

- **Program name**- with this parameter you set the name of the program;
- **Vertical heater**- sets the required temperature of the vertical heater;
- **Front heater**- sets the required temperature of the front horizontal heater;
- **Rear heater**- sets the required temperature of the rear horizontal heater;

The temperatures are set according to the packaging film specifications. The initial setup is performed by our technicians, according to the packaging film sample, sent by the customer.

## 2. Film parameters

Film pull speed	0	%
Bag length (mm)	55	mm
Film - pause before pulling	0.00	s
Film type	Printed	

- **Film pull speed**- this parameter sets the maximum film pulling speed in %. The parameter is set according to the film specifications and the required packaging speed. If the pull speed is too high, it could wear down the pulling belts faster, therefore for lower/medium packaging speeds the recommended value is 70-80%;

- **Bag length**- this parameter sets the required bag length when working with **blank** (non printed film), or the step between the photo marks, when working with **printed** film;

**NOTICE!!!** When working with printed film this parameter could be set automatically from the

**Work panel**, by pressing the **MEASURE**

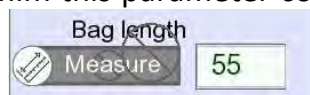

- **Film – pause before pulling**- this parameter sets the pause, before the machine starts to pull the packaging film.

- **Film type**- this parameter sets the working mode according to the film type. If the loaded film is printer with design and has a **photo mark**, the film type should be set to **PRINTED**. This will activate the machine's **photocell** and will ensure equal length bags, according to the design. For non printed packaging film, or such with continuous design (without a photo mar), the film type should be set to **BLANK**. This way the photocell will be ignored and the bag length will be set in mm and measured by the encoding system.



### 3. Jaws parameters

Jaws parameters	
Jaws speed	<input type="text" value="0"/> %
Jaws - pause before closing	<input type="text" value="0.00"/> s
Jaws - sealing time	<input type="text" value="0.00"/> s

- **Jaws speed**- this parameter sets the closing speed of the sealing jaws in %. The bigger the value, the faster the jaws are closed;

- **Jaws – pause before closing**- this parameter sets the pause before the sealing jaws start to close;

- **Jaws – sealing time**- this parameter sets the time of which the sealing jaws remain closed. Usually this parameter is increased when the machine needs to wait for the product with closed jaws, in case of bigger weight of the dose. The parameter is also increased when the packaging film needs more time, in order to ensure a proper sealing.

### 4. Doser parameters

Doser parameters	
Doser - pause before discharging	<input type="text" value="0.00"/> s
Doser - discharging time	<input type="text" value="0.00"/> s
Dosing mode	<input type="button" value="Single dosage"/>

- **Doser – pause before discharging**- sets the time before the ready dose is discharged in the packaging machine;

- **Doser – discharging time**- sets the time, needed for the doser to discharge the entire dose;

- **Dosing mode** - sets the working mode of the dosing device – one dose into single bag or many doses into single bag;

5. **Timing hopper parameters** (used only if timing hopper is available)

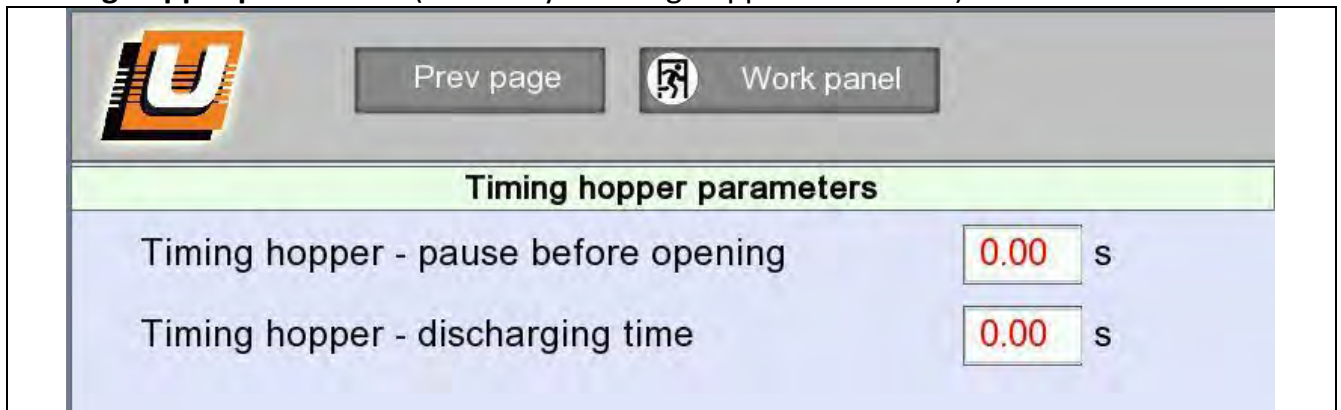

- **Timing hopper – pause before opening**- sets the time before opening the timing hopper;
- **Timing hopper – discharging time**- sets how long the timing hopper stays in open position before closing (set this parameter to ensure that all of the product in the valve is discharged);

6. **Air cylinders parameters**

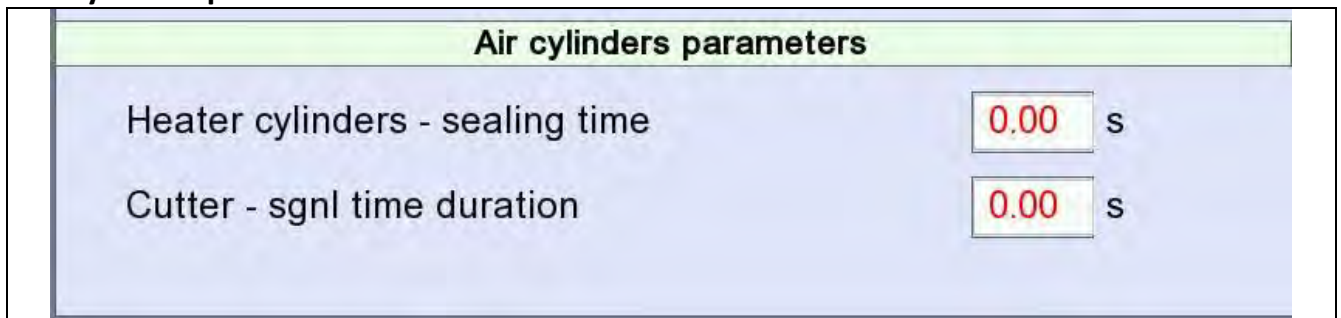

- **Heater cylinders – sealing time**- sets the sealing time of the vertical heater;
- **Cutter – sgnl time duration**- sets the cutting time of the cutter. Default is 0.2 seconds;

**NOTICE!!!** After all of the parameters are set according to your requirements, you need to press the **LOAD** button in order the changes to take effect



## 4.2.4. QUICK ACCESS MENUS

### 1. Temperatures quick access

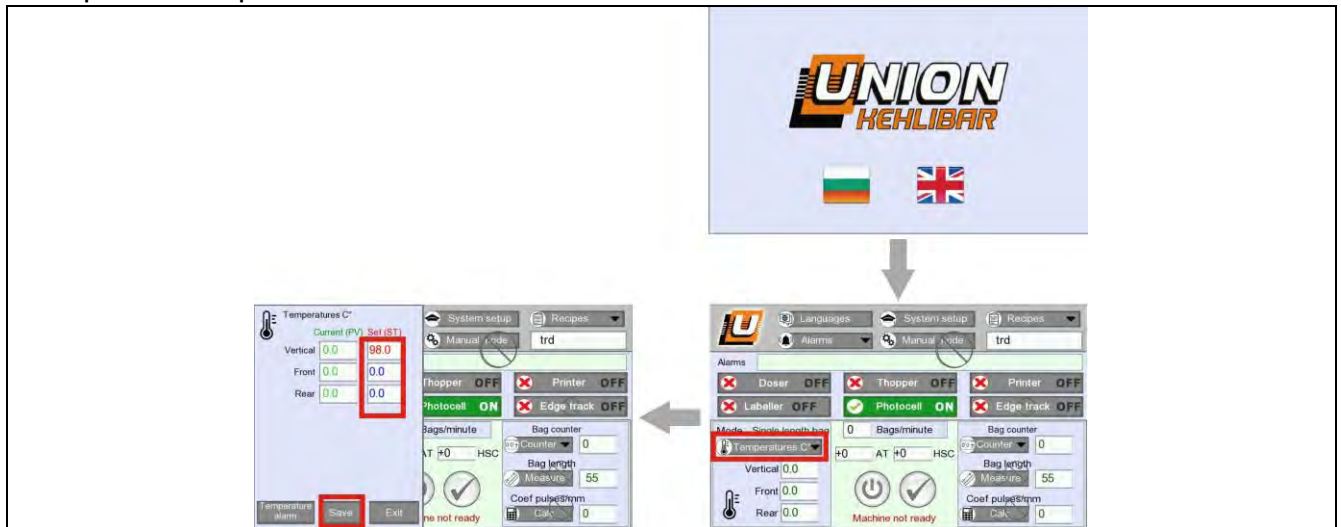

In order to access the **TEMPERATURES** quick menu, press the

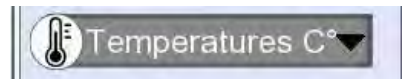

A new window will be opened

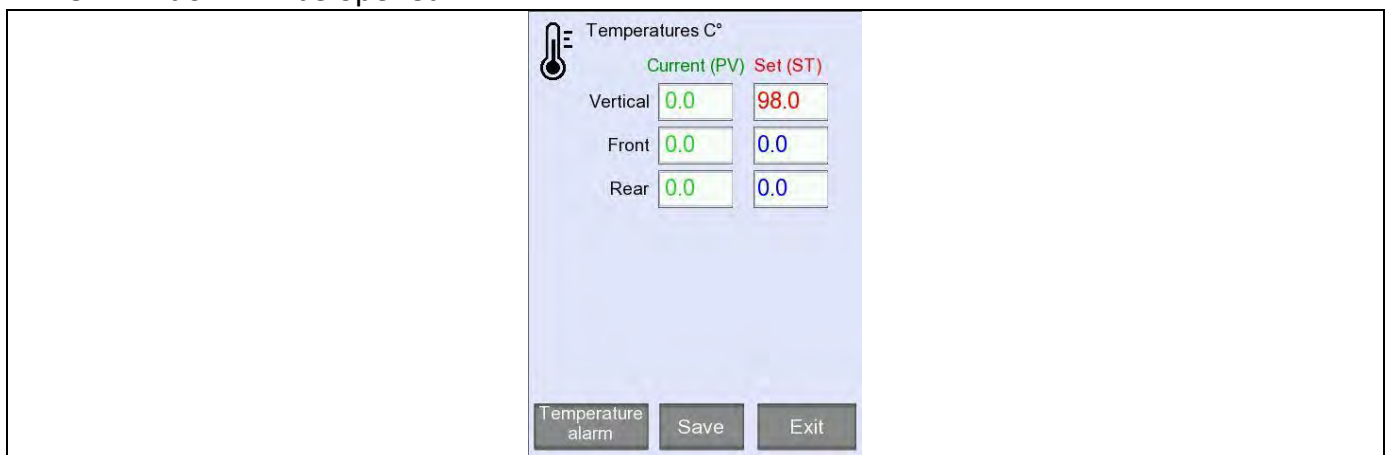

Here you could see both **current** and **set** temperatures of each heater. By changing the **set** value and pressing the  button, the new value will be automatically updated in the **recipe**.

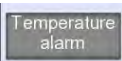
By pressing the  button, you could set a **temperature alarm**. The **alarm** will be activated when the **current** temperature falls under the **set** temperature. Such an event will stop the packaging machine, in order to avoid eventual bag waste due to improper sealing.



## 2. Measuring the bag length (only for printed film)

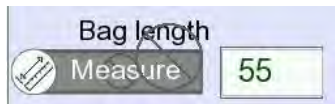

By pressing the **Measure** button, the machine will automatically measure the length of the bag, when working with **printed** film. The measurement will be automatically updated in the current **recipe**.

**NOTICE!!!** The button is accessible **ONLY** when working with **printed** film.

## 3. Setting the counter

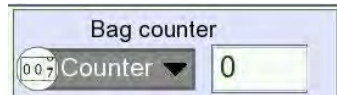

By pressing the **Counter** button, you're entering the **counter** menu. From here you could activate and set the bag **counter** option. After the required bag count is reached, the machine will stop automatically.

## 4. Calculating the Pulse/mm coefficient

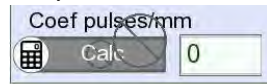

By pressing the **Calc** button, the machine will automatically calculate the Pulse/mm coefficient for servo film pulling motor



### 4.2.5. EXTERNAL DEVICES



This section is used to synchronize the external devices (if any) with the packaging machine. In this section are also visualized the ready/not ready indication, which shows the actual state of each external device. Each external device could be turned ON and OFF.

When an external device is turned ON it's colored in **GREEN** **Photocell ON** with **ON** indication written on it.

When an external device is turned OFF it's colored in **GREY** **Doser OFF** with **OFF** indication written on it.

Each external device can have 2 states: **READY** and **NOT READY**. When an external device is ready for operation, it's marked with . And the opposite, if the device is not ready for operation, it's marked with .

**NOTICE!!!** It is possible that despite a device is **TURNED ON** it might not be ready for operation. This means that there is an issue with the external device. The issues might be as follows:

- The **Doser** is turned on, but there is not a ready dose available;
- The external device is turned **ON** on the machine's panel, but is switched OFF from the electrical supply;
- There is a problem with the external device;

The external devices which could be integrated with the packaging machine are:

1. **Doser**- The main function of the dosing device is the separating of the product into predefined doses, which are set by the machine operator. The ready doses are then fed to the packaging machines.
2. **Timing Hopper** – this device is used to increase the capacity of the machine, especially when the machine is equipped with a multihead weigher;
3. **Printing device** - the thermo transfer printing device is used to print date, lot number, barcode and image to the packaging film.
4. **Labeler** – used to automatically apply label on the bag;
5. **Photocell** – used when working with printed packaging film with photo mark on it. Used to ensure that all of the bags are with equal length and cut in compliance with the design.
6. **Accessories**
  - 6.1 **former vibration** – used to turn on/off the anti-clogging vibration on entry funnel.
  - 6.2 **Bag tapping** – used to turn on/off the bag tapper. Number of tapping could be also set.
  - 6.3 **Static discharger** – used to turn on/off the antistatic bar discharger.

## 4.3 MANUAL MODE

### 4.3.1 Entering the manual mode

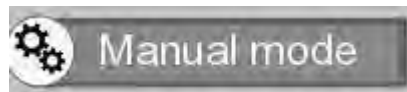
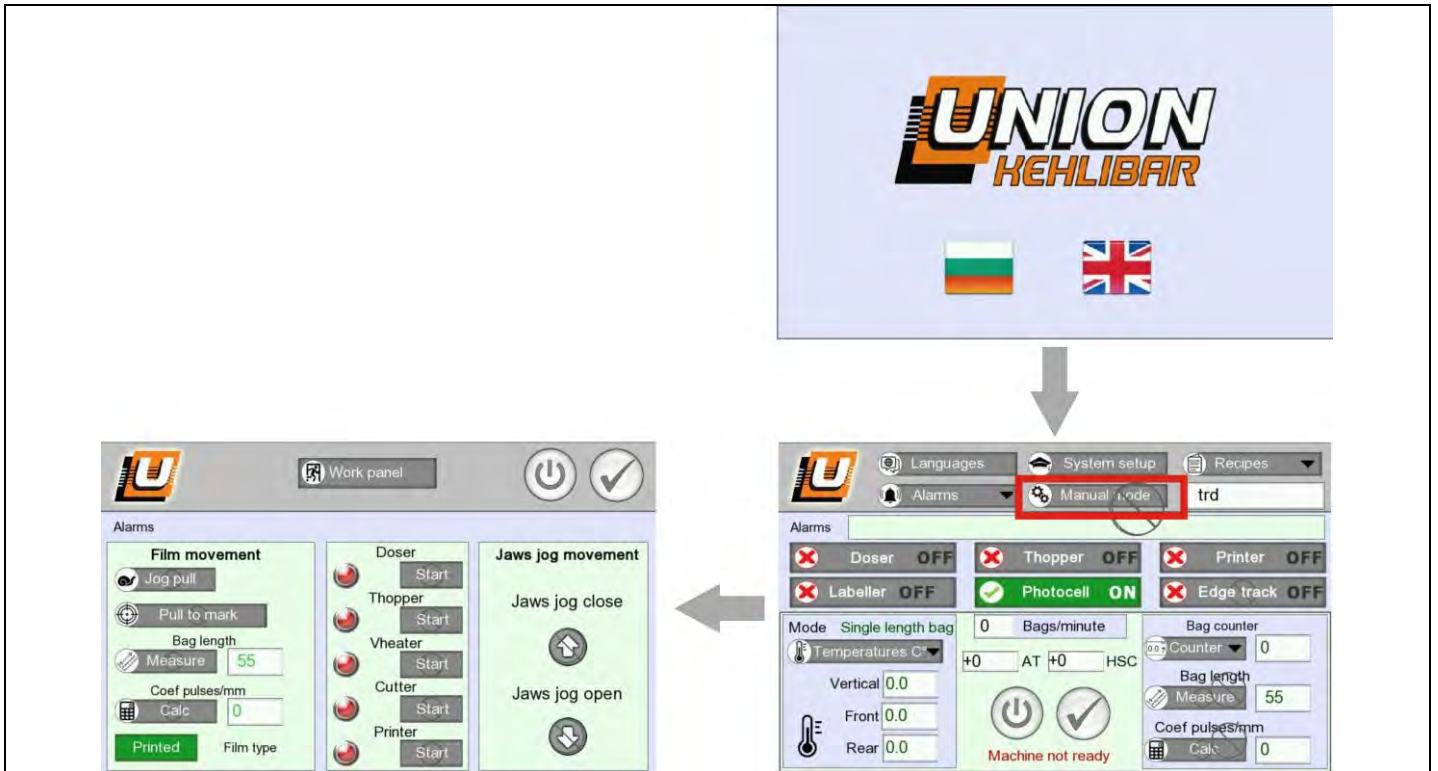

From the **Work Panel** press the  button.

### 4.3.2 Manual mode commands

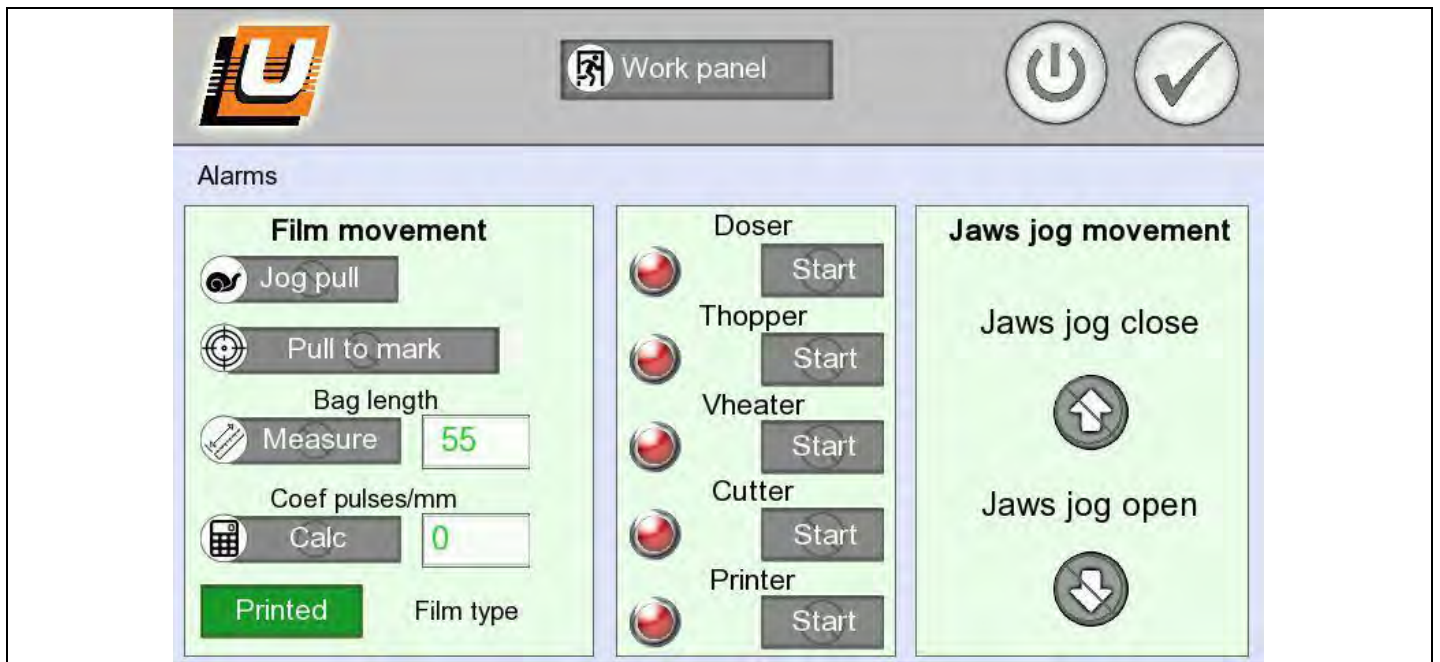

### 1. Film movement

- **Jog pull** - manually activates the film pulling mechanism;
- **Pull to mark** – pulls the packaging film, until reaching the **photo mark** (only when working with **PRINTED** film with photo mark);
- **Measure** – automatically measures the bag length (only when working with **PRINTED** film with photo mark);
- **Film type** – choose the right film type: **PRINTED** or **BLANK**;

### 2. Devices

- **Doser** – discharges the dose (only if there is a ready one);
- **Thopper** – opens the **Timing Hopper**;
- **Vheater** – activates the vertical heater;
- **Cutter** – activates the film cutter;
- **Printer** – activates the thermal transfer printer (in order to test the print);

### 3. Jaws jog movement

- **Jaws jog close** – manually closes the sealing jaws;
- **Jaws jog open** – manually opens the sealing jaws;

## 4.4 SYSTEM SETUP

### 4.4.1 Entering the system parameters

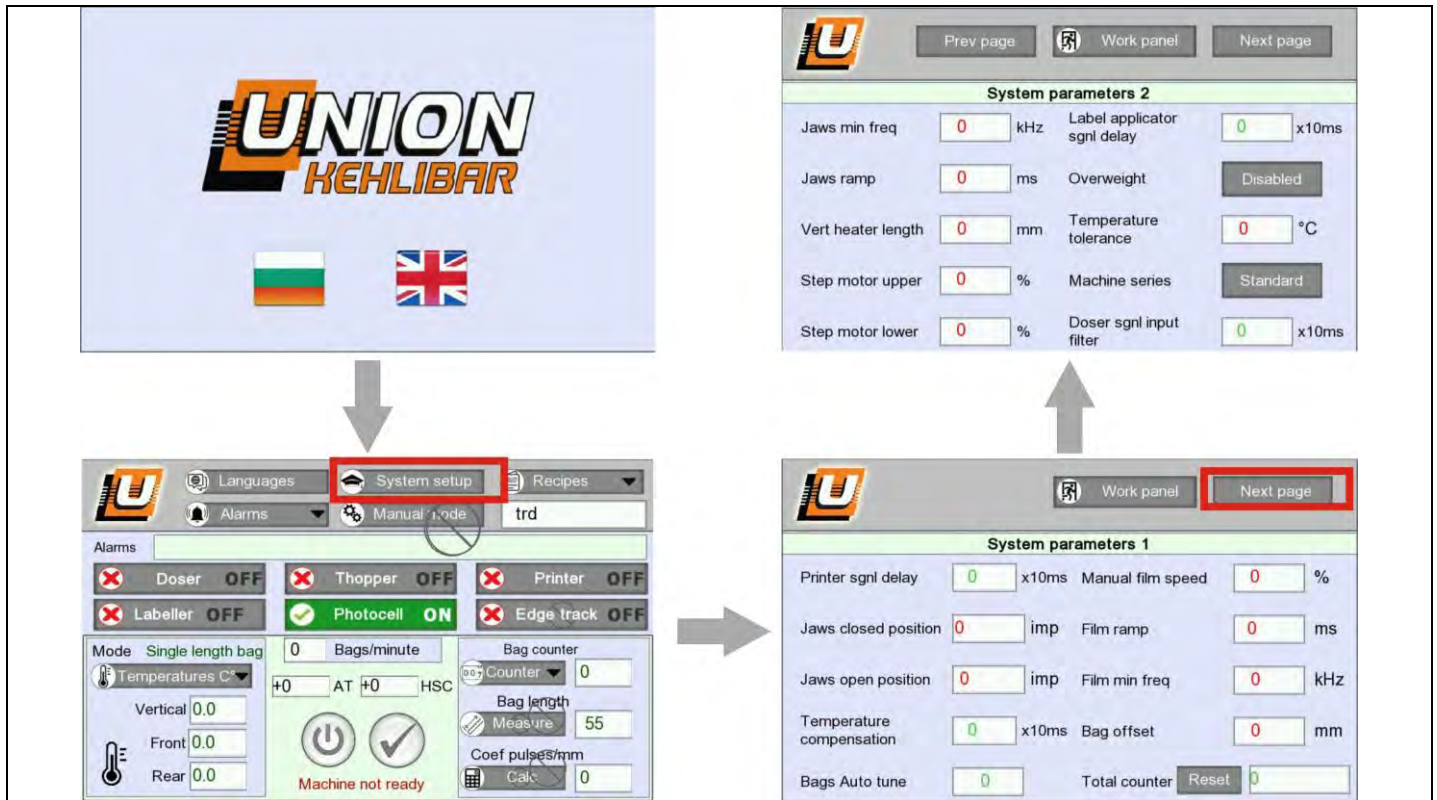



From **Work panel** press the  **System setup** button and enter password **7505**

### 4.4.2 System parameters

#### 1. System parameters #1





 Work panel

Next page

---

### System parameters 1

Printer sgnl delay	<input style="width: 80%;" type="text" value="0"/>	x10ms	Manual film speed	<input style="width: 80%;" type="text" value="0"/>	%
Jaws closed position	<input style="width: 80%;" type="text" value="0"/>	puls	Film ramp	<input style="width: 80%;" type="text" value="0"/>	ms
Jaws open position	<input style="width: 80%;" type="text" value="0"/>	puls	Film min freq	<input style="width: 80%;" type="text" value="0"/>	kHz
Temperature compensation	<input style="width: 80%;" type="text" value="0"/>	x10ms	Bag offset	<input style="width: 80%;" type="text" value="0"/>	mm
Bags Auto tune	<input style="width: 80%;" type="text" value="0"/>		Total counter	<input style="width: 80%;" type="text" value="0"/>	

Reset

- **Printer sgnl delay**- sets the delay before thermal transfer printer start (TTO)

- **Jaws closed position** – sets the jaws close position. For machine model AM019 – 19900, for AM020 - 29900

- **Jaws open position**-sets the jaws open position. Hint: for high speed applications, the jaws may be adjusted not to open to initial home position.

- **Temperature compensation**- sets the pulse time duration which is pulsated to heaters every machine cycle. It is used when the machine speed is too high or if the room temperature is too low

- **Bags Auto tune** – sets the number of machine cycles (bags) after which Auto tune correction is applied

- **Manual film speed** – sets the manual film speed

- **Film ramp** – sets the acceleration/deceleration ramp of the film pulling servo motor

- **Film min freq**- sets the min. frequency of the film pulling servo motor

- **Bag offset**- sets the bag length tolerance. If the bag is within the tolerance, no auto tuning correction is applied and vice versa.

- **Total counter**- counts the total bags number

## 2. System parameters #2

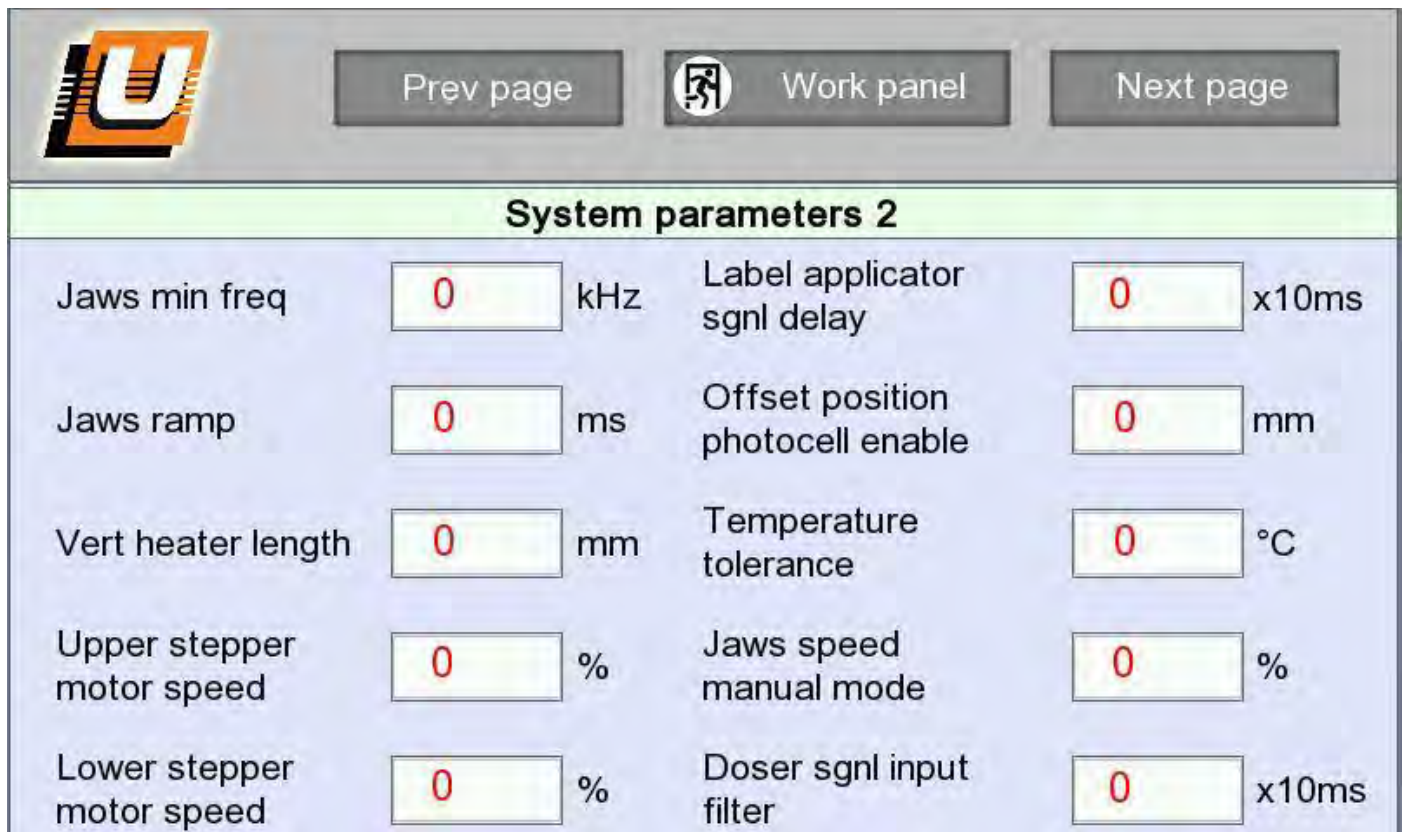

System parameters 2					
Jaws min freq	<input type="text" value="0"/>	kHz	Label applicator sgnl delay	<input type="text" value="0"/>	x10ms
Jaws ramp	<input type="text" value="0"/>	ms	Offset position photocell enable	<input type="text" value="0"/>	mm
Vert heater length	<input type="text" value="0"/>	mm	Temperature tolerance	<input type="text" value="0"/>	°C
Upper stepper motor speed	<input type="text" value="0"/>	%	Jaws speed manual mode	<input type="text" value="0"/>	%
Lower stepper motor speed	<input type="text" value="0"/>	%	Doser sgnl input filter	<input type="text" value="0"/>	x10ms

- **Jaws min freq** – sets the min. frequency of the jaws servo motor

- **Jaws ramp** - sets the acceleration/deceleration ramp of the jaws servo motor

- **Vert heater length** – sets the length of the installed vertical heater

- **Upper stepper motor speed** – sets the speed of the upper unwinding stepper (it is percentage calculated on the base of the set film pulling speed)

- **Lower stepper motor speed** - sets the speed of the lower unwinding stepper (it is percentage calculated on the base of the set film pulling speed)

- **Label applicator signal delay** - sets the delay before start signal to label applicator

- **Offset position photocell enable**– sets the position along bag length where the photocell is activated. If the set bag length is 200mm and offset position photocell enable is 20mm, the photocell will be active in range 180-200mm.

- **Temperature tolerance** - sets the temperature tolerance. If temperature is out of tolerance, an alert is displayed on the screen.



- **Jaws speed manual mode** - sets the jaws speed in manual mode
- **Doser signal input filter** - sets an electronic filter which is applied on DOSER ready signal

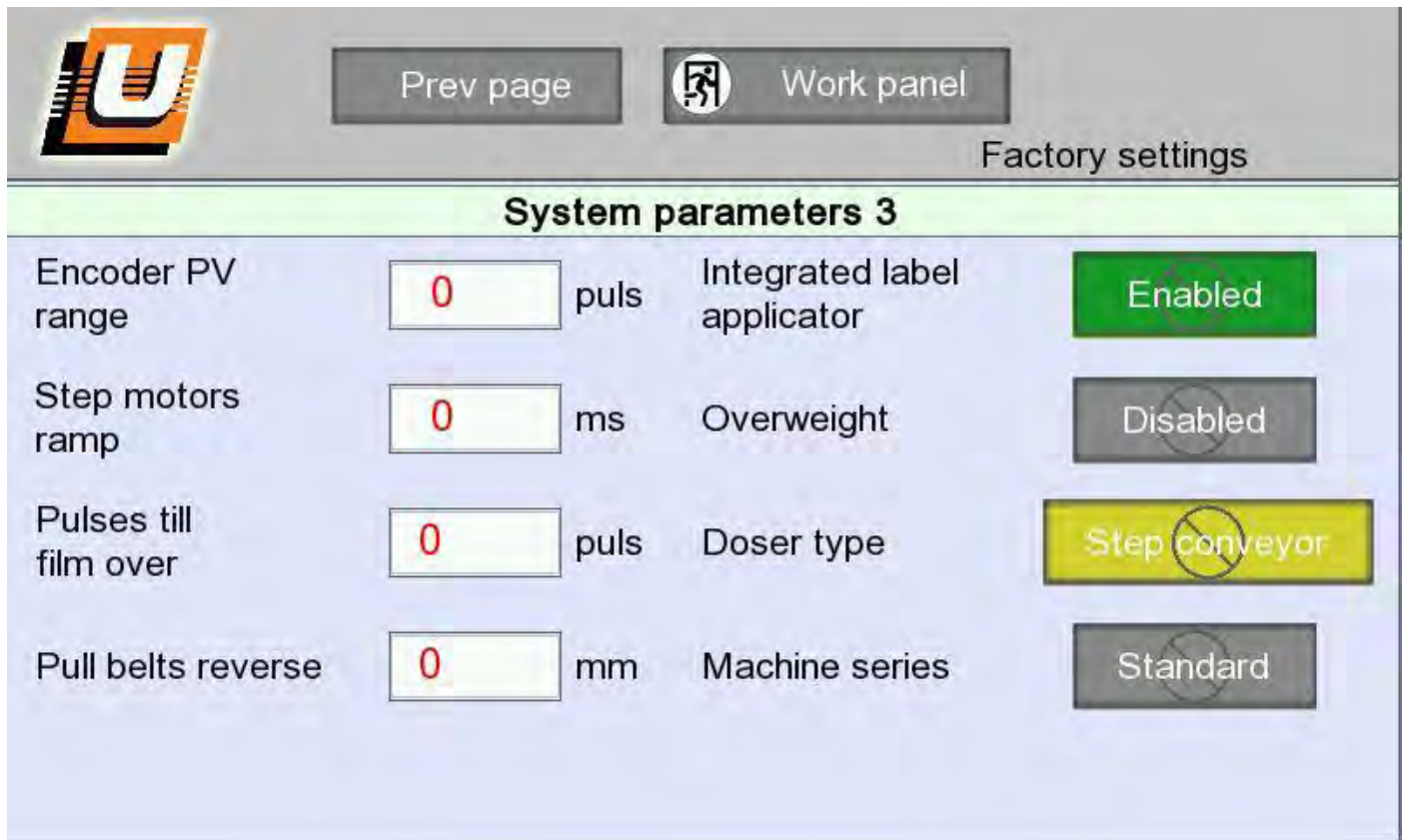

- **Encoder PV range** – sets the encoder preset value tolerance
- **Step motors ramp** – sets the acc/dcc ramp for unwinding stepper motors
- **Pulses till film over** – sets the pulses till film over alarm.
- **Pull belts reverse** – sets pulses in reverse direction before film pulling. Using this option, the pulling belts will move slightly in reverse direction and the pulling the bag length. The option is used for some film materials which tends to stick to the forming tube.
- **Integrated label applicator** – turns on/off setup menu for label applicator (if installed)
- **Overweight** – turns on/off the overweight rejection mode (if installed)
- **Doser type** – select the type of dosing device installed on the machine
- **machine series** – sets the machine type (standard, stabilo or doypack)

**NOTICE!!! The system parameters should be accessed and edited ONLY by qualified personnel OR due the manufacturer's advice.**

## 4.5 Starting the packaging machine

At this point we are ready to start the packaging machine. In order to avoid any damage and additional film and product waste, it's strongly recommended to follow the procedure:

1. Ensure that all of the covers are closed
2. Check the air pressure. The value should be between **4.5-5.5 BAR**

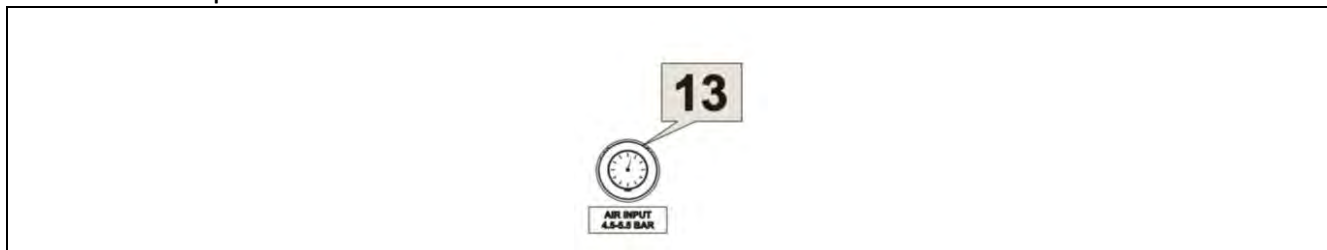

3. Check if the **PULLING BELTS** are locked
4. Check if the set temperature is reached
5. Turn on all the **EXTERNAL DEVICES**, **except** the **DOSER**.



6. **ENABLE THE PACKAGING MACHINE-** **Machine ready** - the status of the machine should be

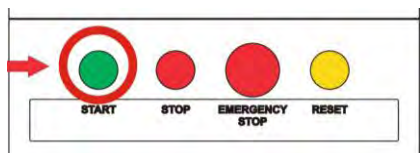

7. Push the start button

The machine will start making empty bags. Make at least 4 bags and push the stop button,

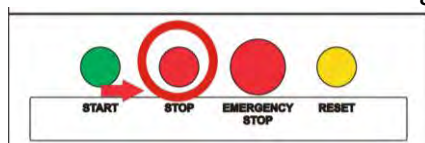

in order to stop the machine.

Check the overall bag quality, vertical and horizontal seals. If everything is according to your requirements, continue the next step.

8. Adjust the cutting position.

When working with printed film, despite the even length of the bags, they might not be cut on the right place, which causes discrepancy with the design. In that case, we need to adjust the cutting position additionally. In order to do that, we need to move the **CUTTING**

**POSITION** shaft forward or backward. The **CUTTING POSITION** shaft is situated on the film cassette

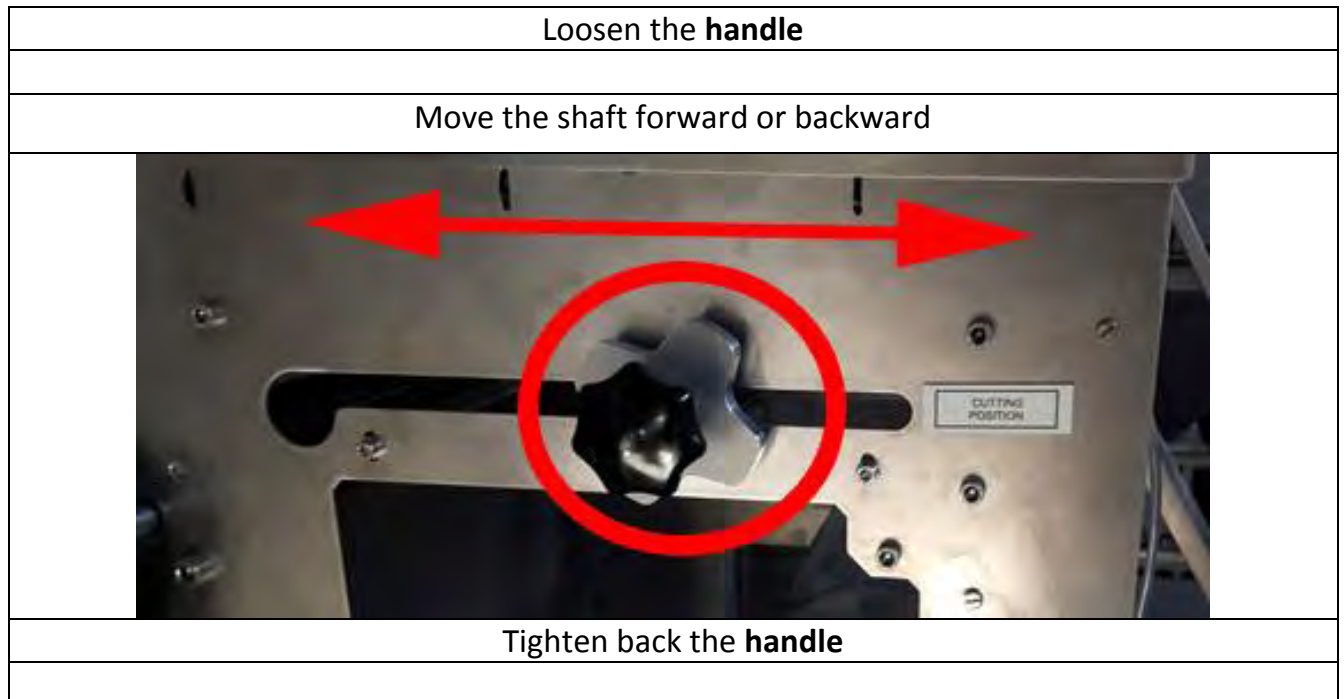

Now test with the new setting. Perform the procedure until you are satisfied with the result.

9. Continue making empty bags until you see **printing** (date, lot number or text) from the thermal transfer printer.  
Check the position of the print on the final bag. If the print is not on the right position, we need to readjust it accordingly.

#### **Adjustment of the horizontal printing position:**

The printer is situated on the film cassette.

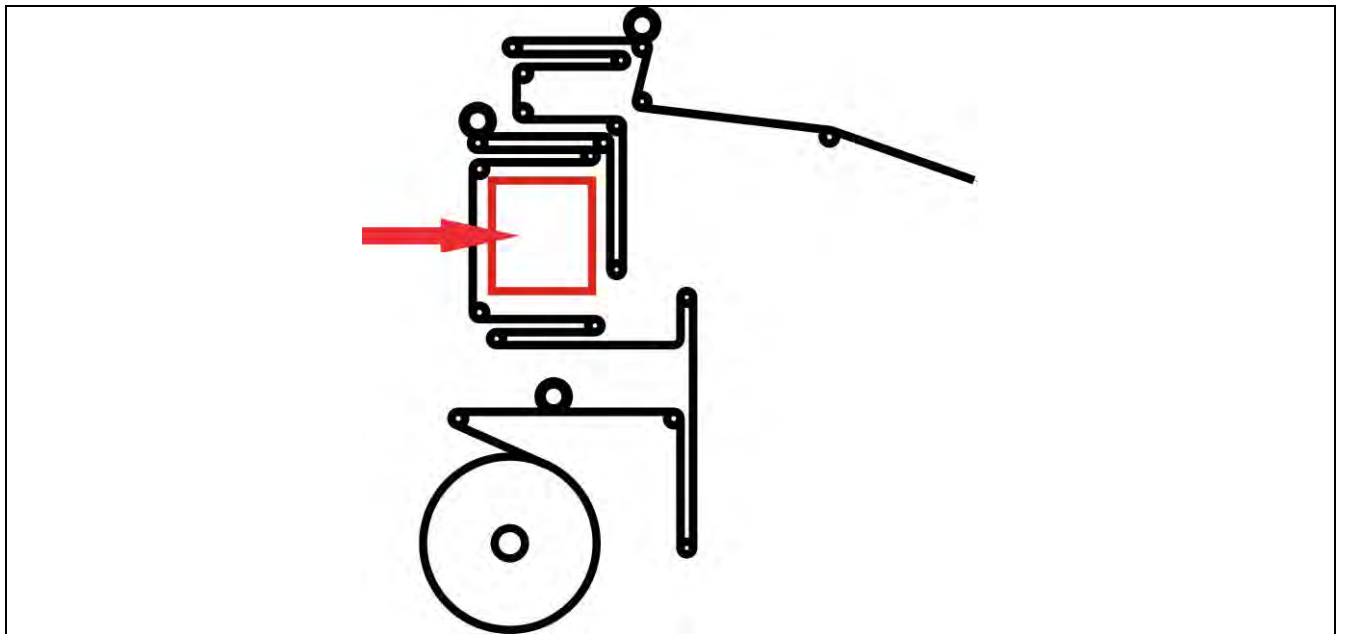

Loosen the **handle**

Move the horizontal plate along with the **printer** left or right

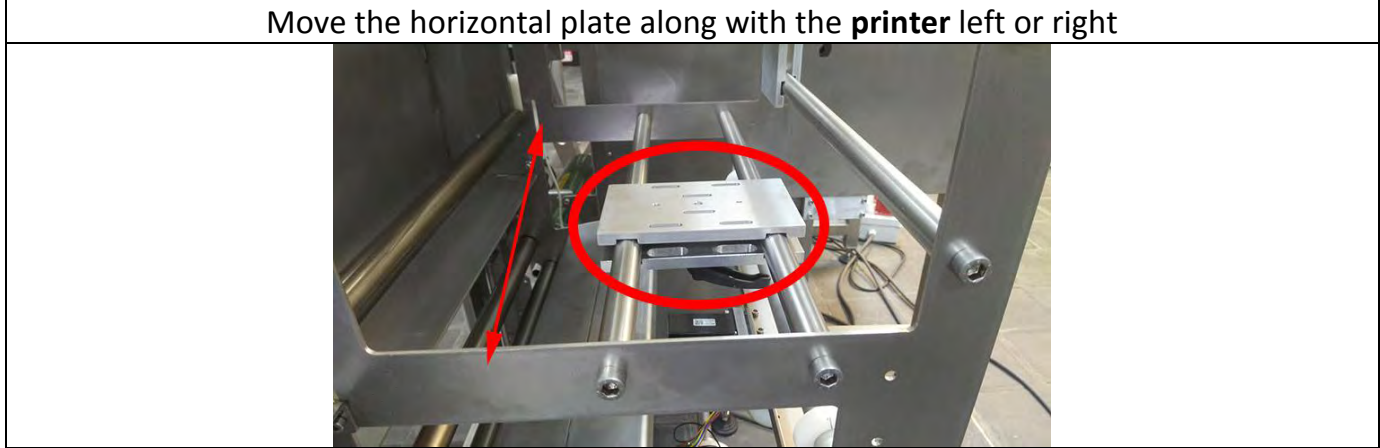

Loosen the **handle** of the **opposite plate**

Move the **opposite plate** left or right, in order to match the **printing head**

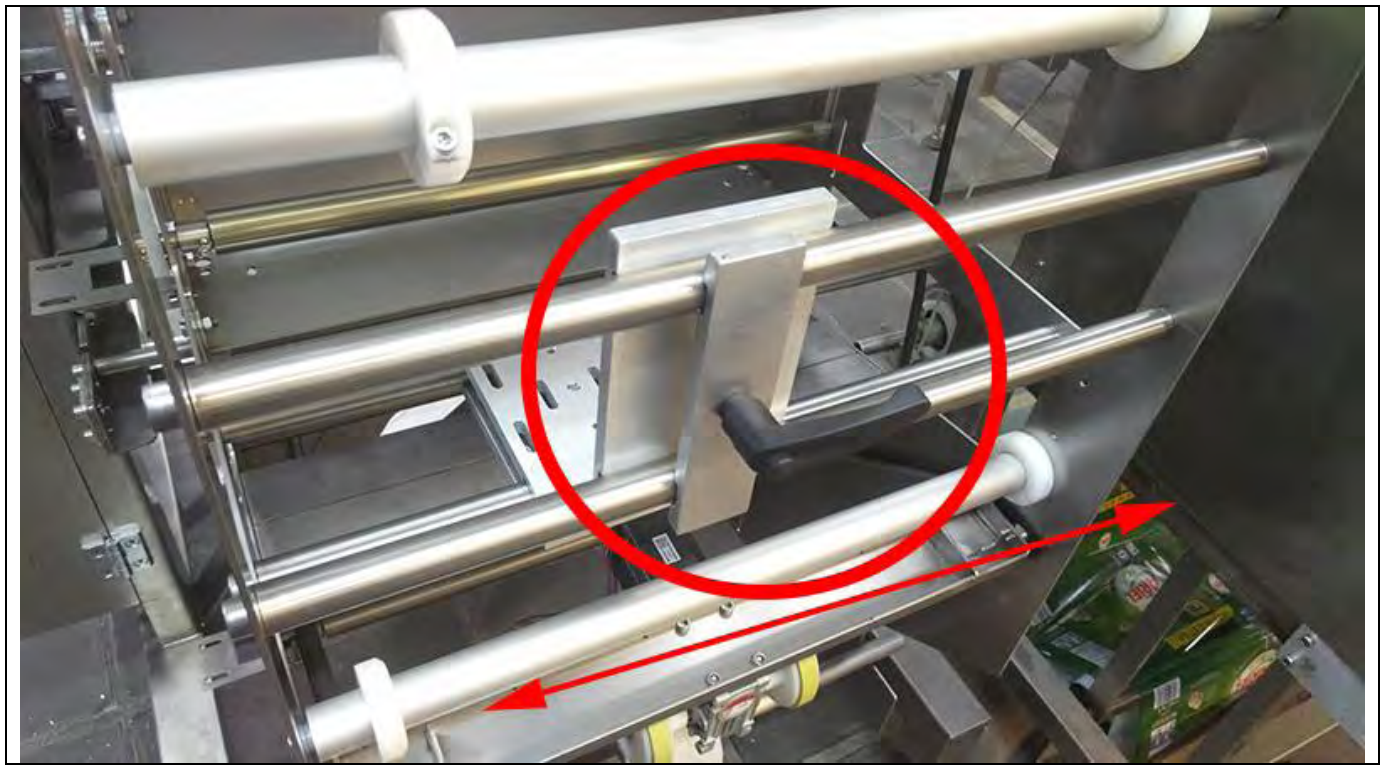

**Adjustment of the vertical printing position:**

Loosen the <b>handle</b>	
Move the shaft forward or backward	
Tighten back the <b>handle</b>	

Now test with the new setting. Perform the procedure until you are satisfied with the result.



10. When all the setup is done and you have the final bag with proper design and printing, it's time to **TURN ON** the dosing system and start the packaging process.

#### 4.5 Startup checklist

- Close **covers**
- Check **air pressure**
- Check **pulling belts**
- Check if the **temperature** is reached
- Turn on **printer**
- Turn on **labeler**
- Enable** the machine
- Check final bag
- Check **cut position**
- Check **print position**
- Check **label position**
- Turn on **doser**
- Check if any **alarms** are present

### 5. WORKING WITH THE DOSING DEVICE

#### 5.1 Step conveyor type dosing device setup

If step conveyor dosing device is enabled, you could setup it by pressing expanding button DOSER

**Step conveyor setup**

Steps number

1

✘
Doser
OFF

Filling mode

Single

Discharging mode

Single

Pause before conveyor start

0.00

s

Load

Exit

Rear

0.0

Machine not ready

Calc

0

- Steps number – sets the number of steps/bowls the conveyor will move
- Filling mode – sets the working mode for the dosing stations (single or row)
- Discharging mode – sets the working mode for step conveyor (single or row)
- pause before conveyor start – sets the time delay before conveyor start.

Steps number	Filling mode	Discharging mode	Meaning
1	Not active	Not active	Standard working mode. The conveyor moves one step and one bowl is discharged to the packaging machine.
>1	Row	Row	The conveyor moves the setup steps in one cycle and discharges the whole cycle in one single bag.
>1	Row	Single	The conveyor moves the setup steps in one cycle and discharge the cycle in steps/ in separate bags.
>1	Single	Single	The conveyor moves the setup steps one by one and discharge the whole cycle in

			one single bag.
>1	Single	Row	Invalid mode

## 6. WORKING WITH A LABEL APPLICATOR

If integrated label applicator option is enabled, you could setup it by pressing expanding button LABELLER

### 6.1 Parameters

- single label – ejects a single label on slow/manual speed. Used to setup correct stop position
- error reset – used to reset errors related with the label applicator.
- stop position – sets the label stop position on the dispensing beak. Usually, the label start should stop 5-10mm after the end of dispensing beak.  
Notice: stop position should be selected in a way the label is not touching the packaging film. When packaging film is pulled, the applicator is synchronized with the film speed and label is fed in parallel with the film.
- start delay – sets a time delay on label start cycle.
- label length – sets the label length. The length includes the paper gap also.
- manual speed – sets the manual speed which is active in single feed label mode

- max label length – (read only value). Once the label length is set, the max length is automatically calculated. If no photocell is detected within max label length value, an alarm is initiated.
- stepper start ramp – sets the starting acceleration of the step motor;
- stepper stop ramp – sets the stopping deceleration of the step motor

## 6.2 Label loading schema

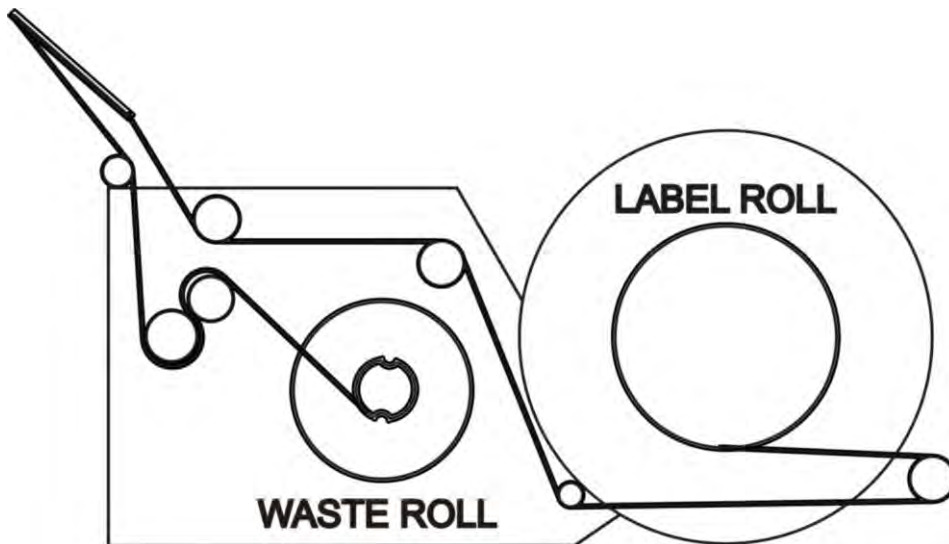

## **TROUBLESHOOTING**

<b>Problem</b>	<b>Possible causes</b>	<b>Troubleshooting</b>
The machine cannot be turned on	A circuit breaker is tripped off.	Check if all the circuit breakers are ON
The bags are not well sealed	<ul style="list-style-type: none"> <li>- low temperature;</li> <li>- the sealing time is not long enough;</li> <li>- low quality or not appropriate film;</li> <li>- broken spring;</li> </ul>	<ul style="list-style-type: none"> <li>- increase the sealing bars' temperatures</li> <li>- increase the sealing time by changing 1t parameter.</li> <li>- change the packaging film;</li> <li>- check if all the springs are intact.</li> </ul>
Film varying motion in left-right direction	<ul style="list-style-type: none"> <li>- the film is not centered to the forming tube;</li> <li>- the film roll is not properly wound.</li> <li>- unequal friction of the packaging film.</li> </ul>	<ul style="list-style-type: none"> <li>- center the film roll to the forming tube. If there is more film on the left side of the collar, compensate as moving the film roll in the right;</li> <li>- change the film roll;</li> <li>- check if all the shafts are clean; if the variations in film motion are not significant, the film motion might be stabilized using guides to keep it moving on the right track.</li> </ul> <p>If the variations are significant, change the film roll.</p>
The machine is ON but it doesn't start after pressing the START button	<ul style="list-style-type: none"> <li>- the emergency button is pressed.</li> <li>- some of the buttons don't function;</li> </ul>	<ul style="list-style-type: none"> <li>- released the emergency button;</li> <li>- make sure that all the buttons function as expected (with OHMMETER)</li> </ul>
The film pulling rolls are slipping	- dirty or dusty pulling rolls;	-clean the pulling rollers;
The bags are not well cut	- blunt cutter;	- replace the cutter;



## MAINTENANCE

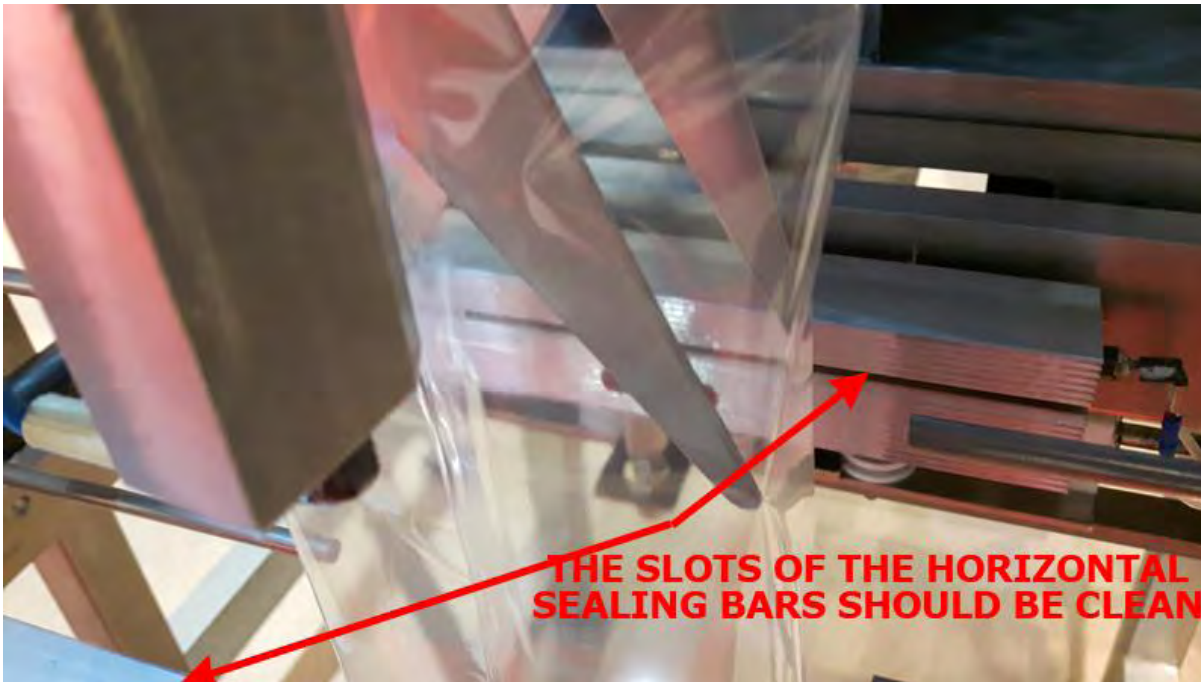

All the surfaces in contact with the product should be cleaned with spirit or other special preparations which are not hazardous and allowed to be used in food processing industry.

The film pulling rollers should be kept clean, without dust. They should be cleaned with a piece of cloth and spirit. An indication that the rollers should be cleaned is that if they start slipping instead of pulling the packaging film.

The slots in the horizontal sealing bars should be kept clean so that the cutter must be able to get in and out from the slots without any obstructions.

If the slots are filled with product or other remnants, the cutter could curve or distort and obstruct the smooth movement of the sealing bars mechanism.

### Lubrication

All sliding parts, chains and joints should be lubricated weekly.

Do not use solid greases since they tend to build up. Use light oils like WD40 spray.

