

4

3

2

1

C-2

ALL DIMENSIONS ARE IN INCHES
UNLESS OTHERWISE SPECIFIED.

ALL TOLERANCES ARE $\pm 0.0325''$
UNLESS OTHERWISE SPECIFIED.

MATERIAL THICKNESS = 0.9"
UNLESS OTHERWISE SPECIFIED.

B

B

A

A

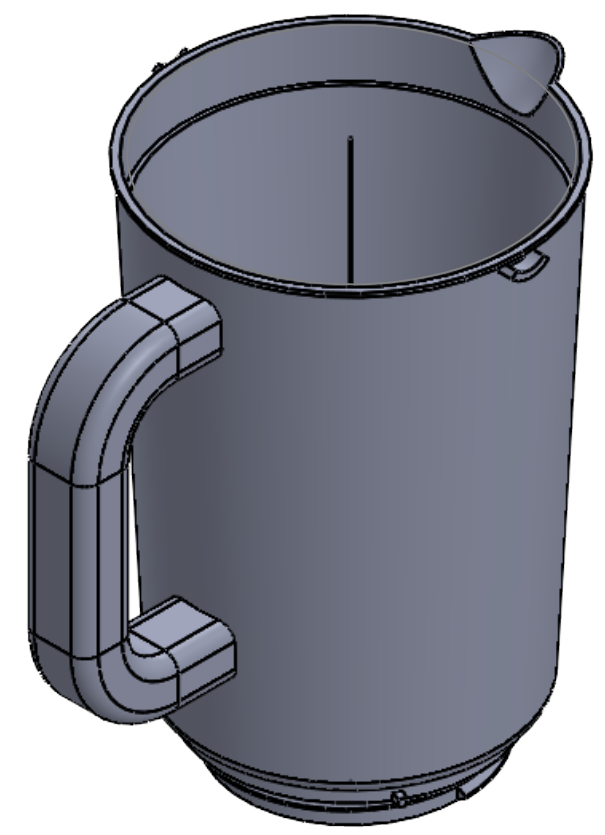
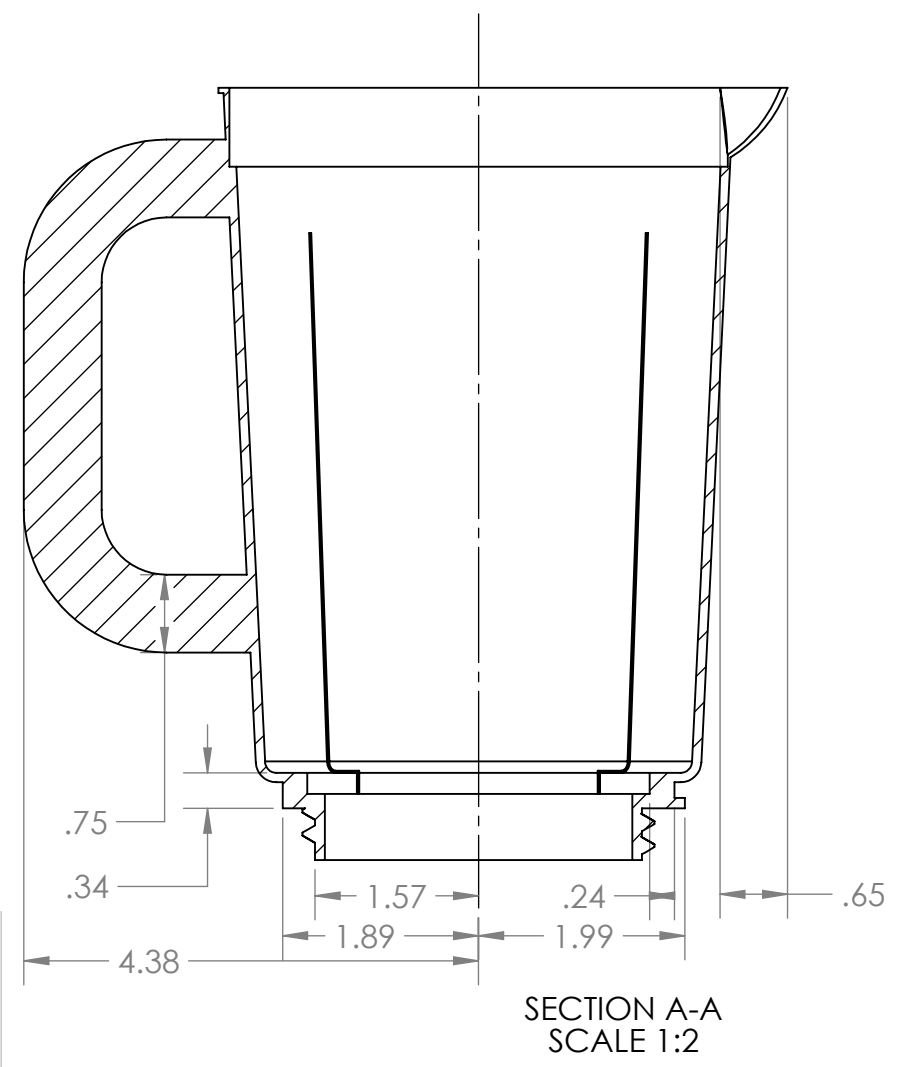
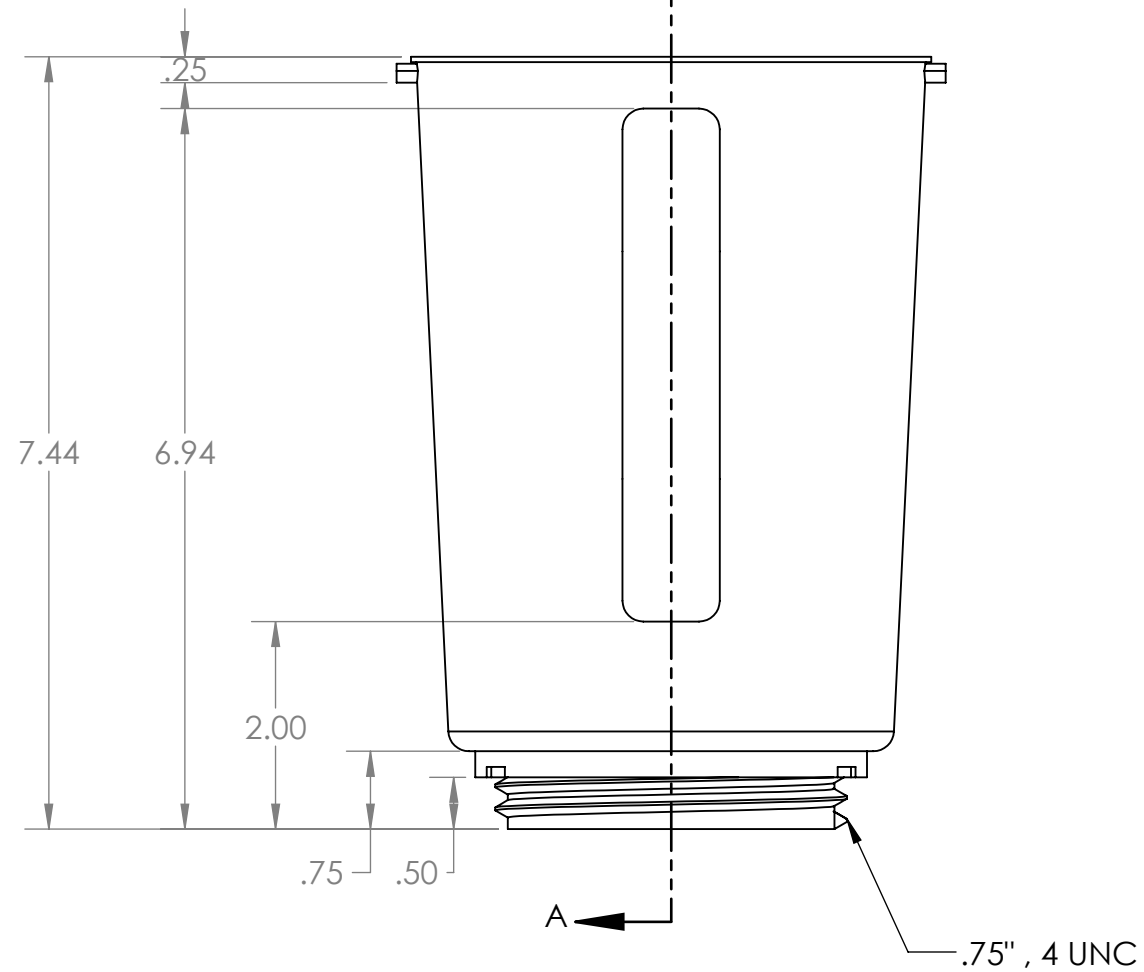
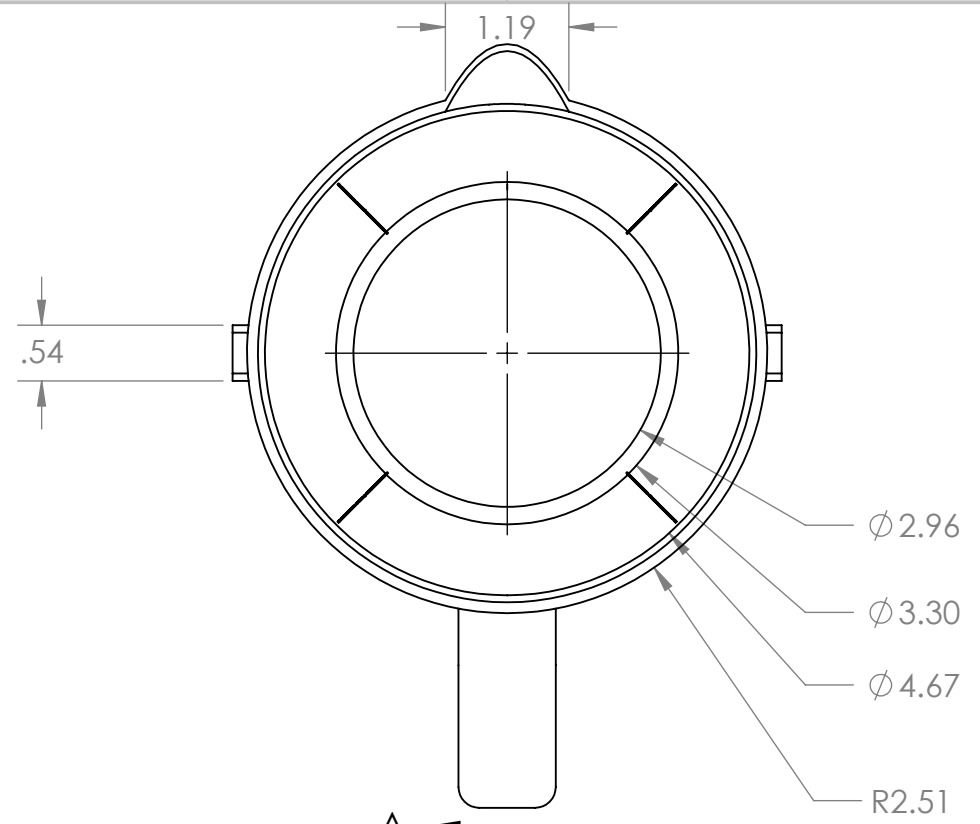

NAME: REAGAN COURVILLE		
TITLE: TEAM #2 BLENDER TEARDOWN		
SIZE B	DWG. NO. Pitcher	REV
SCALE: 1:5	WEIGHT:	SHEET 1 OF 1

4

3

2

1