

MR-P 750

MR-P LINE
PILING RIG



MARINI

MR-P 750

MR-P LINE
COMPACT PILING RIG



/ Working to grow together

MR-P 750

MR-P



COMPONENTISTICA COMPONENTS

Marini Srl si distingue per l'uso di componenti di altissima qualità, selezionati accuratamente per garantire prestazioni superiori. La scelta delle migliori materie prime e dei prodotti finiti di eccellenza assicura una maggiore durabilità dei macchinari, riducendo i guasti e i tempi di fermo.

Marini Srl stands out for using top-quality components, carefully selected to ensure superior performance. The choice of the finest raw materials and finished products guarantees a longer lifespan for machinery, reducing breakdowns and downtime.



SOSTENIBILITÀ SUSTAINABILITY

Marini Srl si impegna a produrre macchine da perforazione all'avanguardia, con un forte focus sulla sostenibilità ambientale. Ogni macchina è progettata per ridurre al minimo l'impatto ecologico, utilizzando tecnologie che ottimizzano il consumo energetico e riducono le emissioni.

Marini Srl is dedicated to producing cutting-edge drilling machines with a strong focus on environmental sustainability. Each machine is designed to minimize ecological impact, utilizing technologies that optimize energy consumption and reduce emissions.

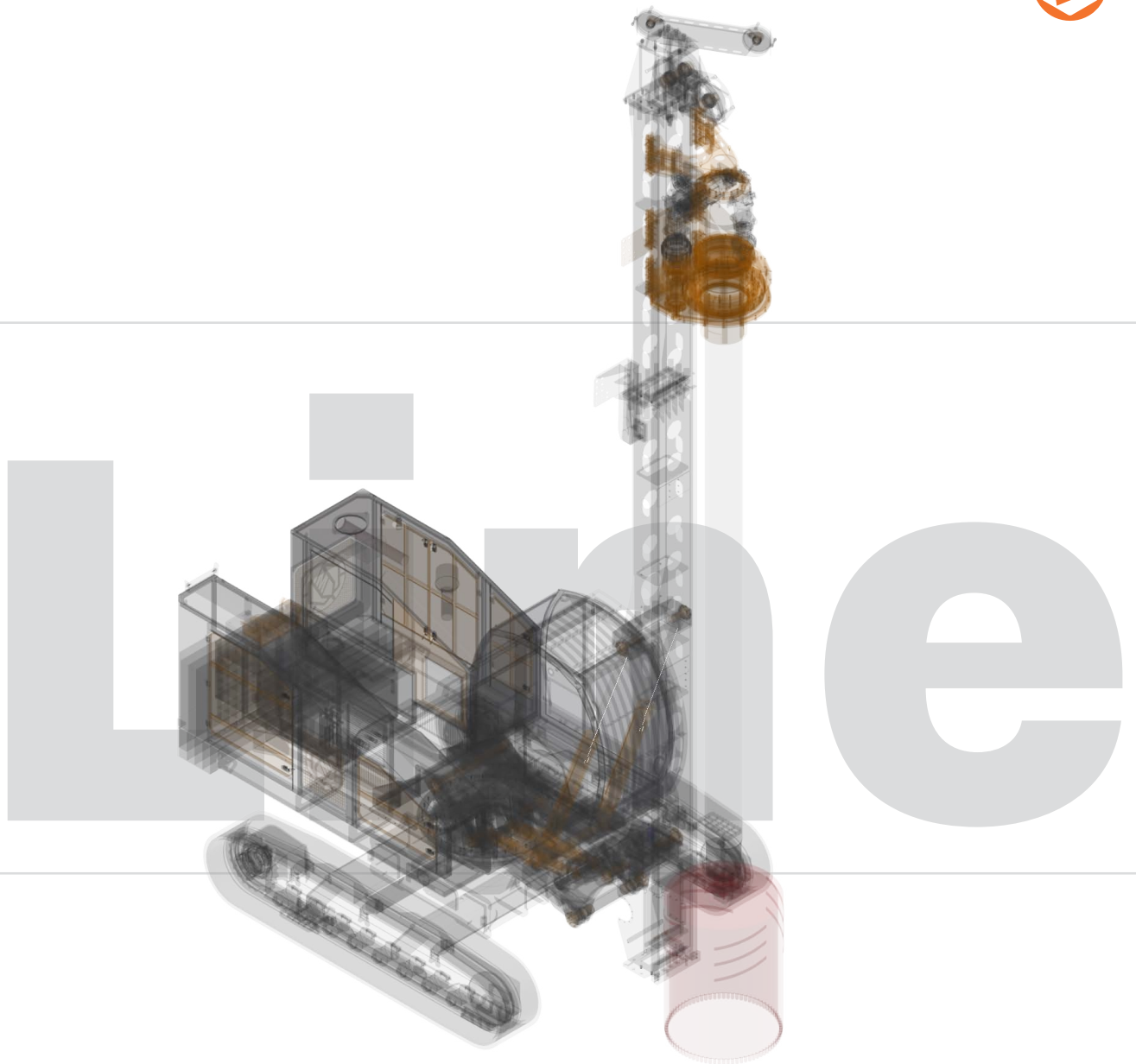

OPERATIVITÀ OPERATION

Le perforatrici Marini sono progettate per garantire un'operatività intuitiva e semplice. Grazie a un'interfaccia user-friendly e a soluzioni tecniche innovative, rende le nostre macchine ideali per i cantieri di tutto il mondo, dove l'efficienza e la facilità d'uso sono fondamentali per ottenere risultati rapidi e di alta qualità.

Marini drilling machines are designed to ensure intuitive and simple operation. Thanks to a user-friendly interface and innovative technical solutions, our machines are ideal for construction sites around the world, where efficiency and ease of use are essential for achieving fast, high-quality results.



AFFIDABILITÀ RELIABILITY

Le perforatrici Marini sono sinonimo di affidabilità e durata nel tempo. Ogni macchina è progettata per resistere alle condizioni più impegnative, garantendo prestazioni elevate anche nei cantieri più difficili. Offriamo un eccellente servizio di ricambi e assistenza tecnica, assicurando che ogni componente sia disponibile tempestivamente.

Marini drilling machines are synonymous with reliability and long-lasting performance. Each machine is designed to withstand the toughest conditions, ensuring high performance even in the most demanding construction sites. We offer an excellent spare parts and technical support service, ensuring that every component is promptly available.

/ MR-P Line

MR-P 750

SOTTOCARRO	CHARIOT CHENILLE	ALLARGABILE - EXPANDABLE	
UNDERCARRIAGE	FAHRWARK		
Passo cingolo Wheel base	Enpattement Fahrwerk	2500 mm / 8.2 ft	
Careggiata variabile Variable track	Voie variable Standbreite verstellbar	2500 - 3500 mm (8.2 - 11.5 ft)	
Larghezza soles Pad width	Langeur patins Fussbreite	500 mm / 1.64 ft	
Pendenza max. Max. climbing ability	Pente max. Steigfähigkeit max.	60%	
Velocità max. Max. speed	Vitesse max. Fahrgeschwindigkeit	2.5 Km/h (15.5 mph)	
MOTORE	MOTOR	ZERO TAIL	
ENGINE	MOTEUR		
Motore Diesel Diesel Engine	Moteur diesel Dieselmotor		JONH DEERE 4045HF550
Potenza motore Engine Power	Puissance moteur Antriebsleistung		103kW (140 Hp) @2200 rpm
Serbatoio Gasolio Fuel Tank	Dieseltank Réservoir Diesel		300 Litri /79.2 gal
Raffreddamento Cooling	Kühlung Refroidissement		Scambiatore aria olio separato Separate oil air exchanger
Consumo carburante Fuel consumption	Consommation carburant Kraftstoffverbrauch		6 - 7 l/h (1.6 - 1.86 gal/h)
TORRETTA	BAGGERTURM	ZERO TAIL	
TURRET	TOURELLE		
Velocità di rotazione Rotation speed	Drehgeschwindigkeit Vitesse de rotation		10 rpm
Larghezza Width	Breite Largeur		2500 mm (8.2 ft)
Certificazione cabina Cabin certificate	Kabinenzertifizierung Certification de cabine		ROPS - TOPS & FOPS
Computer di bordo On board computer	Bordcomputer Ordinateur de bord		7" display / M-Tronic system
Raggio di coda Tail radius	Heckradius Rayon de queue	3050 mm (10 ft)	

/ MR-P Line



MR-P 750

ARGANO IDRAULICO HYDRAULIC WINCH	TREUIL HYDRAULIQUE H. SEILWINDE	PRINCIPALE MAIN	SERVIZIO SERVICE
Tiro max. Max. pull	Max. Zugkraft Traction maxi	7200 daN / 15870 lbf	3600 daN / 7940 lbf
Controllo Control	Seillänge Longueur du câble	Discendente controllato Controlled Descendent	Discendente controllato Controlled Descendent
Diametro fune Rope diameter	Seildurchmesser Diamètre du fil	20 mm (0.78")	12 mm (0.47")

TESTA DI ROTAZIONE ROTARY HEAD	TÊTE DE ROTATION DREHKOPF	R-75	
Coppia max. Max. torque	Couple max. Drehmoment max.	7500 daNm (55320 ft*lb)	
Velocità di perforazione Drilling speed	Vitesse max. Drehzahl max.	0/60 rpm	
Numero di motori Number of motor	Nombre de moteurs Anzahl der Motoren	2	
Velocità di scarico Spin-off speed	Vitesse de décharge Entladegeschwindigkeit	100 rpm	

M-TRONIC

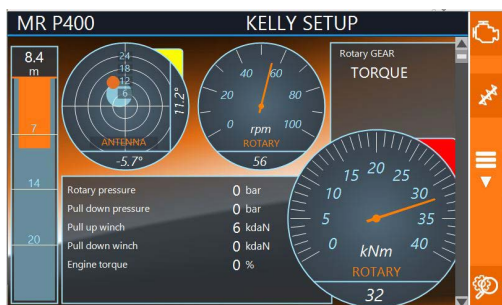

M-TRONIC	
Settaggio sistema (Kelly / CFA)	System settings (Kelly / CFA)
Regolazione pressioni e velocità manovre	Pressure and speed settings
Inclinometro mast	Mast inclinometer
Profondimetro	Depth meter
Programma manutenzione	Service program
Connessione interattiva in tempo reale	Interactive connection in real time

- M-TRONIC è la nuova interfaccia per l'operatore dotata di schermo ad alta definizione touch screen, per tenere sott'occhio tutti i parametri e gestire le funzioni della macchina da perforazione.

- M-TRONIC is the new operator interface equipped with a high definition touch screen, to keep an eye on all the parameters and manage the functions of the drilling machine

/MR-P Line



ITA
Piattaforma di palificazione
compatta



MR-P350 BP



MR-P400 BP

ENG
Compact piling rig

MR-P 750 BP

La MR-P 750 è una macchina da perforazione cingolata per l'esecuzione di pali trivellati semplici o rivestiti con sistema Kelly Bar (BP) e pali ad elica continua (CFA). Le dimensioni compatte e il sistema di automontante rendono questa macchina ideale per lavorazioni rapide in spazi ristretti.

L'innovativa impiantistica idraulica ed elettronica sviluppata da Marini, incrementano sicurezza, performance, affidabilità e facilità d'uso grazie alla nuova interfaccia operatore/macchina.

Adatta principalmente al lavoro in situazioni ristrette e LHR (Low Head Room) grazie al suo mast compatto e cinematismi che permettono una maggiore flessibilità di posizionamento.

The MR-P 750 is a crawler piling rig for the execution of bored piles, cased bored piles with Kelly Bar (BP) system and continuous flight auger piles (CFA). The compact dimensions and the self-erecting system make this machine ideal for rapid works in confined spaces.

The innovative hydraulic and electronic systems developed by Marini increase safety, performance, reliability and facility of use thanks to the new operator / machine interface.

Mainly suitable to work in restricted areas and LHR (Low Head Room) conditions thanks to the compact mast and articulation design that allows flexible positioning options.

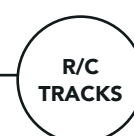
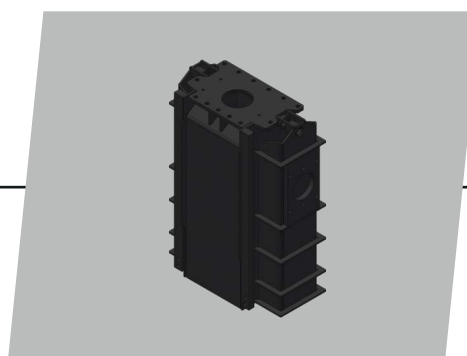



MPD Line

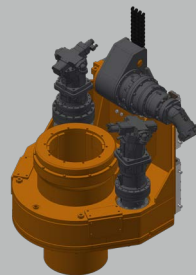
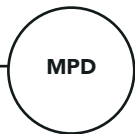

/MR-P Line

MR-P 750 BP



OPTIONS



TESTA R 75 (DOPPIO MOTORE)
ROTARY R 75 (DOUBLE MOTOR)



KELLY BAR 5 ELEMENTI
KELLY BAR 5 ELEMENTS



ARGANO PRINCIPALE A DOPPIA VELOCITÀ
TWO SPEED MAIN WINCH



KIT CONVERSIONE CFA
CFA CONVERSION KIT

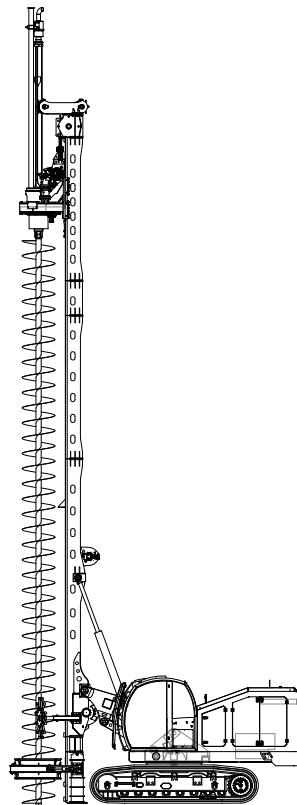

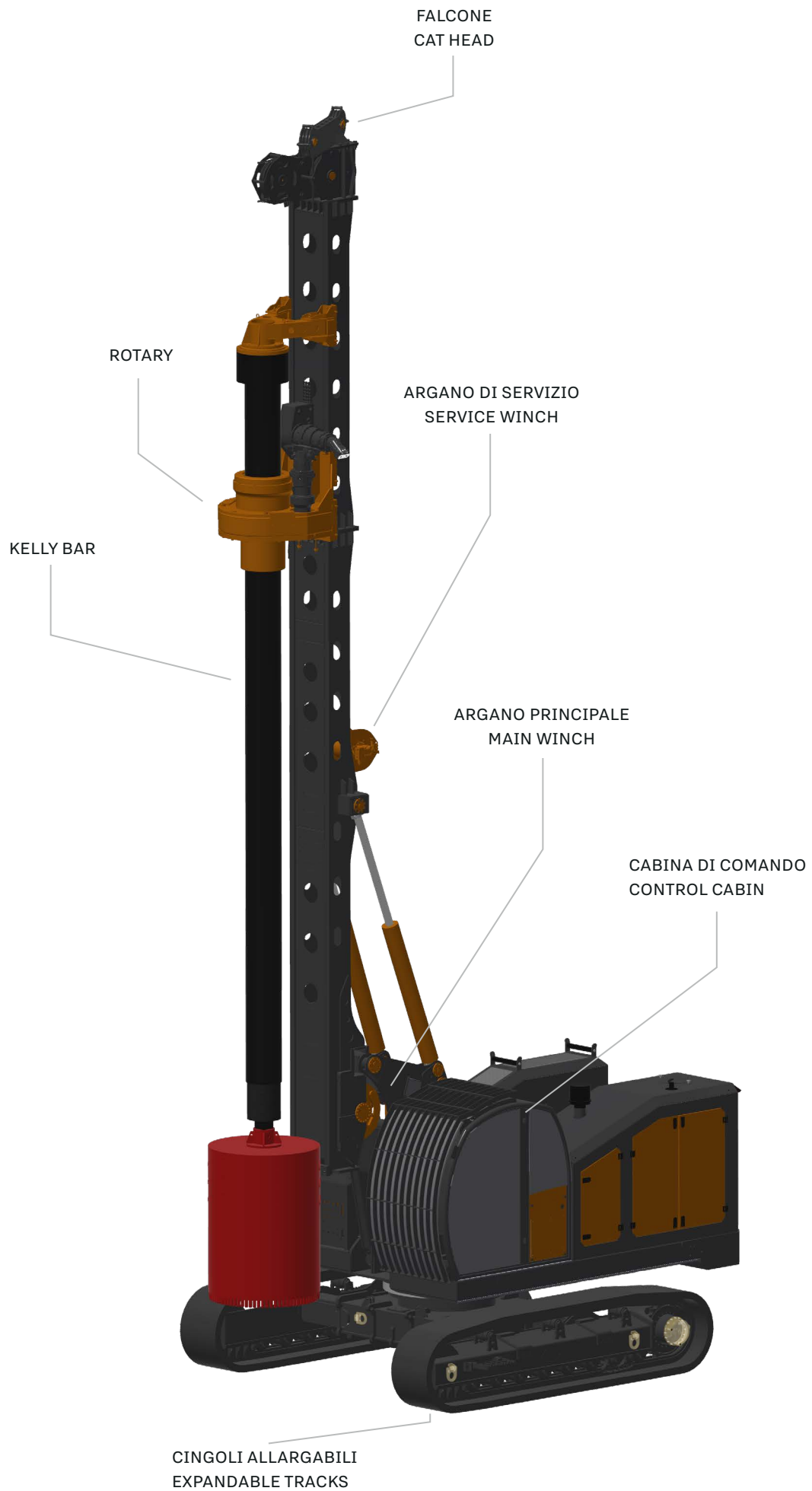

/ MR-P Line

MR-P 750 BP CPD

CILINDRO PULLDOWN PULLDOWN CYLINDER	PULLDOWN CYLINDRE PULLDOWN ZYLINDER	CPD
Corsa utile Feed stroke	Course utile Vorschub	2000 mm / 6.5 ft
Forza di spinta Feed force	Poussée Vorschubkraft	10000 daN / 22050 lbf
Forza di tiro Retract force	Traction Rückzugskraft	8000 daN / 17640 lbf

PERFORAZIONE DRILLING	BOHRUNG FORAGE	
Diametro Max Max. Diameter	Max. Durchmesser Max. Diamètre	1200 mm / 47.2 in
Diametro Min Min. Diameter	Min. Durchmesser Min. Diamètre	400 mm / 15.7 in

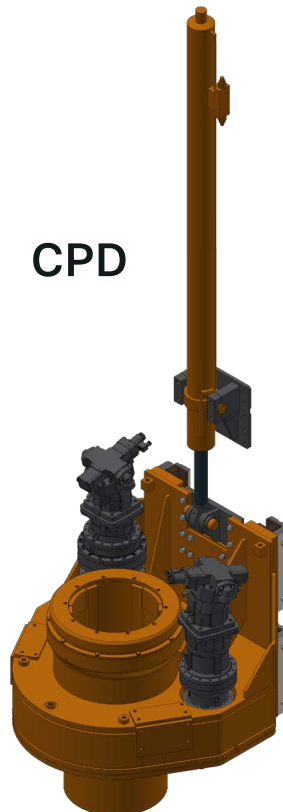

DIMENSIONS



CPD

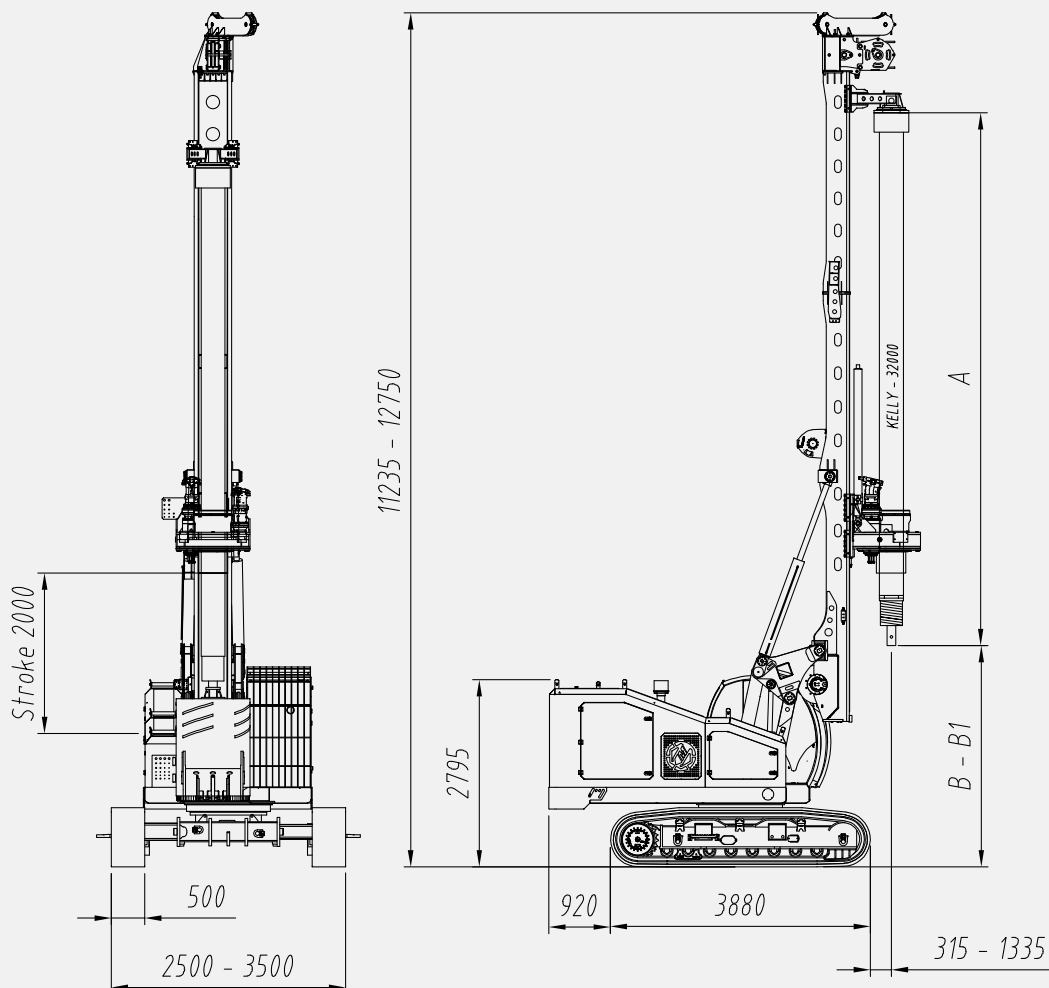

CPD LH

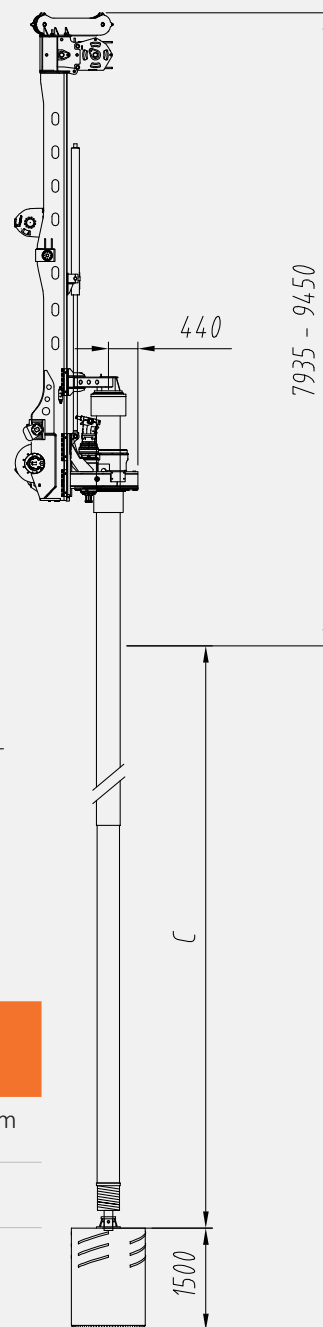

KELLY BAR (A)	PROFONDITÀ DEPTH (C)	PESO WEIGHT	CPD B - B1	CPD LH B - B1
5 x 4550 mm	15 m / 49.2 ft	2500 kg / 5511 lb	4000 - 2485 mm 13.1 - 8.15 ft	3400 - 1885 mm 11.15 - 6.2 ft
5 x 5950 mm	22 m / 72.1 ft	3200 kg / 7055 lb	4000 - 2485 mm 13.1 - 8.15 ft	/
5 x 7150 mm	28 m / 91.8 ft	3750 kg / 8270 lb	4000 - 2485 mm 13.1 - 8.15 ft	/
5 x 7950 mm	32 m / 105 ft	4200 kg / 9260 lb	3300 - 1785 mm 10.8 - 5.85 ft	/

CONNESSIONE KELLY / KELLY CONNECTION 130 X 130 mm

(*) dimensioni variabili su richiesta / dimension variable on request / dimensions variables sur demande / variable abmessungen auf anfrage

/ MR-P Line

MR-P 750 BP MPD

MOTORE PULLDOWN MOTOR PULLDOWN	PULLDOWN MOTEUR PULLDOWN MOTOR	MPD	MPD LH
Corsa utile Feed stroke	Course utile Vorschub	7800 mm / 25.6 ft	4500 mm / 14.7 ft
Forza di spinta Feed force	Poussée Vorschubkraft	10000 daN / 22050 lbf	
Forza di tiro Retract force	Traction Rückzugskraft	8000 daN / 17640 lbf	

PERFORAZIONE DRILLING	BOHRUNG FORAGE	
Diametro Max Max. Diameter	Max. Durchmesser Max. Diamètre	1100 mm / 43.3 in
Diametro Min Min. Diameter	Min. Durchmesser Min. Diamètre	400 mm / 15.7 in

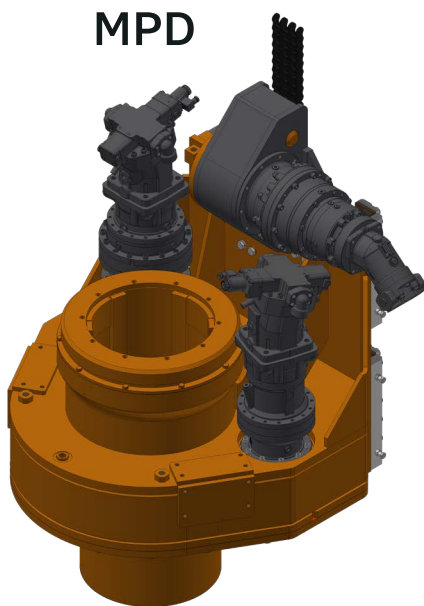

DIMENSIONS



MPD

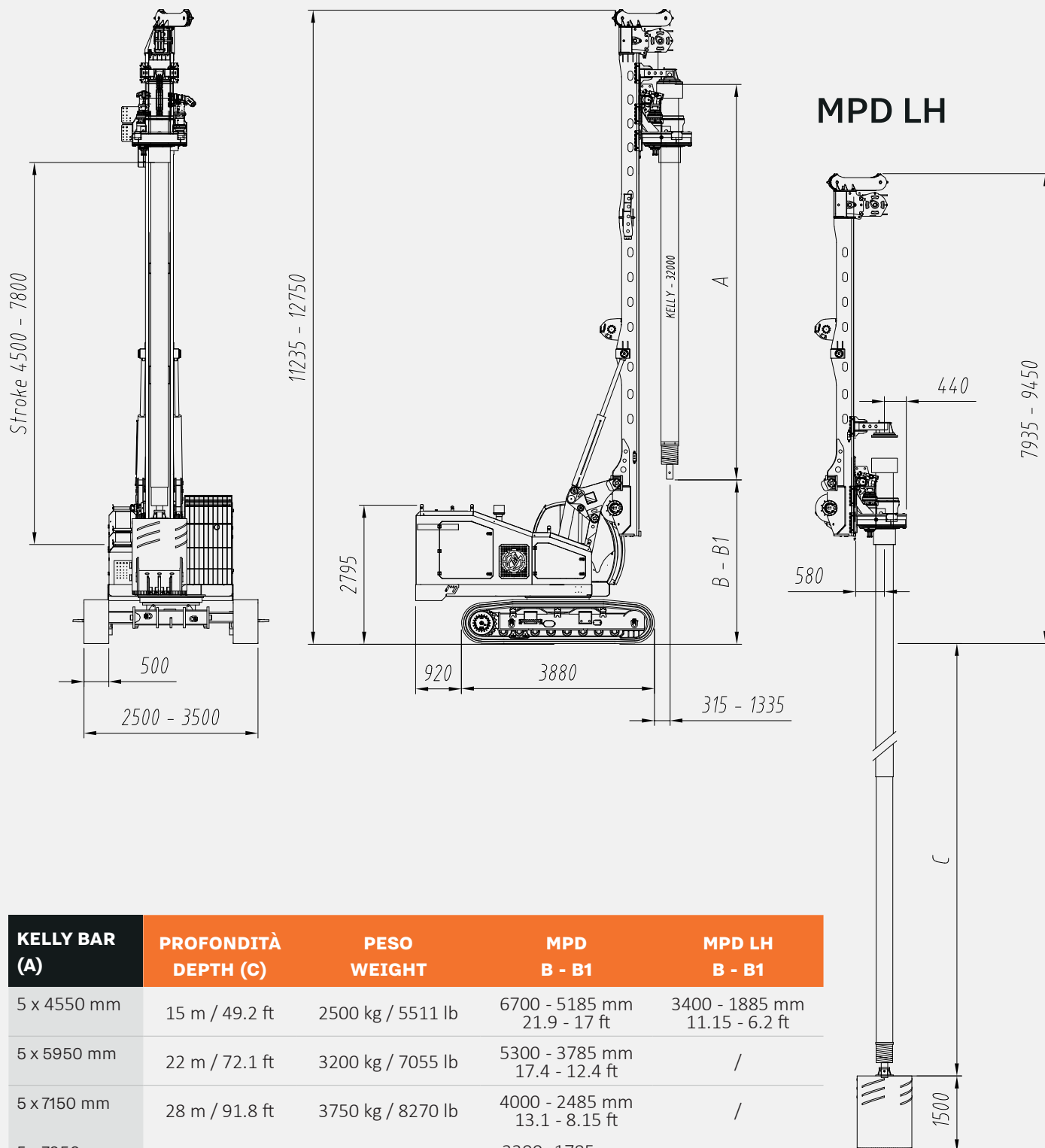

KELLY BAR (A)	PROFONDITÀ DEPTH (C)	PESO WEIGHT	MPD B - B1	MPD LH B - B1
5 x 4550 mm	15 m / 49.2 ft	2500 kg / 5511 lb	6700 - 5185 mm 21.9 - 17 ft	3400 - 1885 mm 11.15 - 6.2 ft
5 x 5950 mm	22 m / 72.1 ft	3200 kg / 7055 lb	5300 - 3785 mm 17.4 - 12.4 ft	/
5 x 7150 mm	28 m / 91.8 ft	3750 kg / 8270 lb	4000 - 2485 mm 13.1 - 8.15 ft	/
5 x 7950 mm	32 m / 105 ft	4200 kg / 9260 lb	3300 - 1785 mm 10.8 - 5.85 ft	/

CONNESSIONE KELLY / KELLY CONNECTION 130 X 130 mm

(*) dimensioni variabili su richiesta / dimension variable on request / dimensions variables sur demande / variable abmessungen auf anfrage

/MR-P Line



ITA
Piattaforma di palificazione
compatta

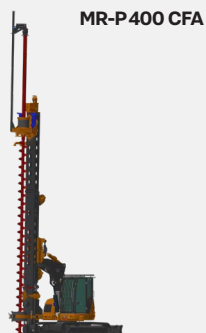

MR-P 400 CFA

ENG
Compact piling rig

MR-P 750 CFA

L'ultima arrivata ma anche la più performante, la MR-P 750 è l'unità da perforazione per pali trivellati e CFA per eccellenza. Grazie alle sue 2 configurazioni differenti in versione CFA — CFA (Continuous Flight Augers), CFA EX (Continuous Flight Augers Extended) — questa macchina è perfetta per l'esecuzione di pali fino ad una profondità massima di 17 mt. Con un peso operativo che varia tra le 28 e le 30 tonnellate, la MR-P 750 si distingue nel mercato per la sua robustezza, potenza e la versatilità delle sue configurazioni, offrendo prestazioni elevate in ogni tipo di intervento.

The latest addition and also the most high-performance, the MR-P 750 is the ultimate drilling rig for bored piles and CFA. With 2 different configurations in CFA version — CFA (Continuous Flight Augers) CFA EX (Continuous Flight Augers Extended) — this unit perfectly fits in the execution of piles up to 17 mt deep. With an operating weight ranging from 28 to 30 tons, the MR-P 750 stands out in the market for its robustness, power, and configuration versatility, offering top performance in any type of project.

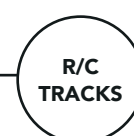

MR-P Line

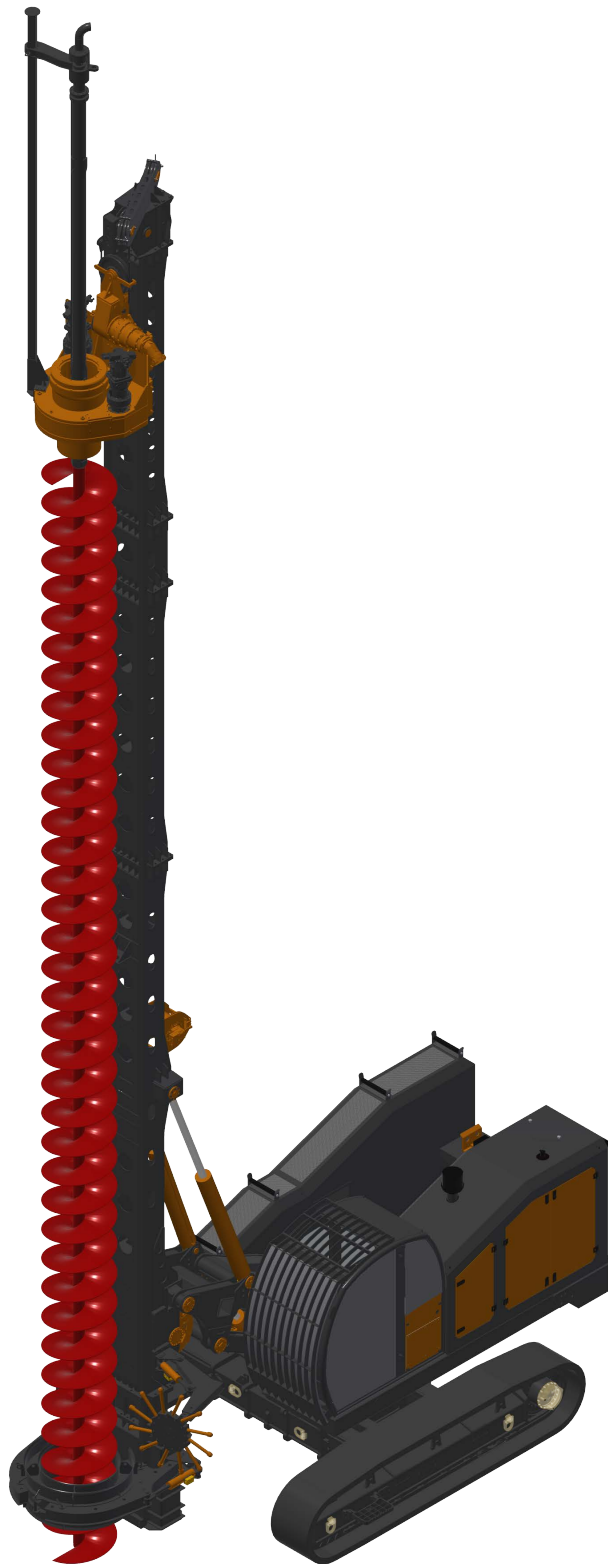

MW



/MR-P Line

MR-P 750 CFA



OPTIONS



MOTORE PULL DOWN
PULL DOWN MOTOR



ASTA DI PROLUNGA CFA (LUNGA / CORTA)
CFA EXTENSION ROD (LONG / SHORT)



GUIDA ELICA IDRAULICO
HYDRAULIC AUGER GUIDE



KIT CONVERSIONE BP
BP CONVERSION KIT

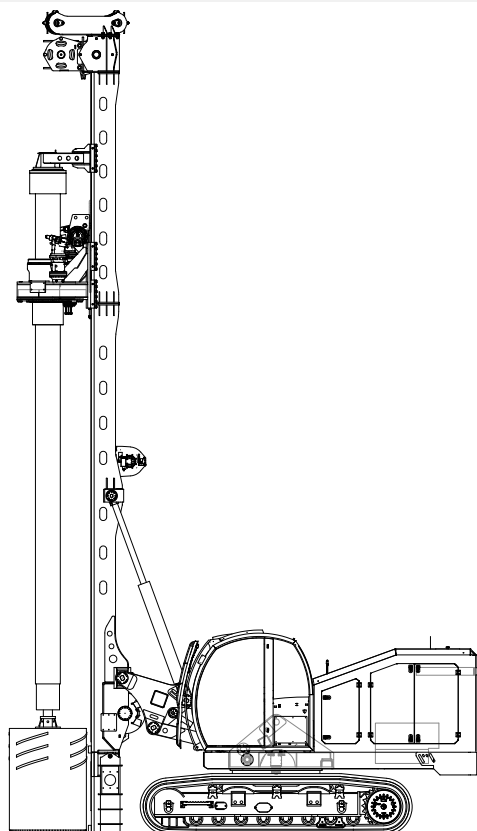

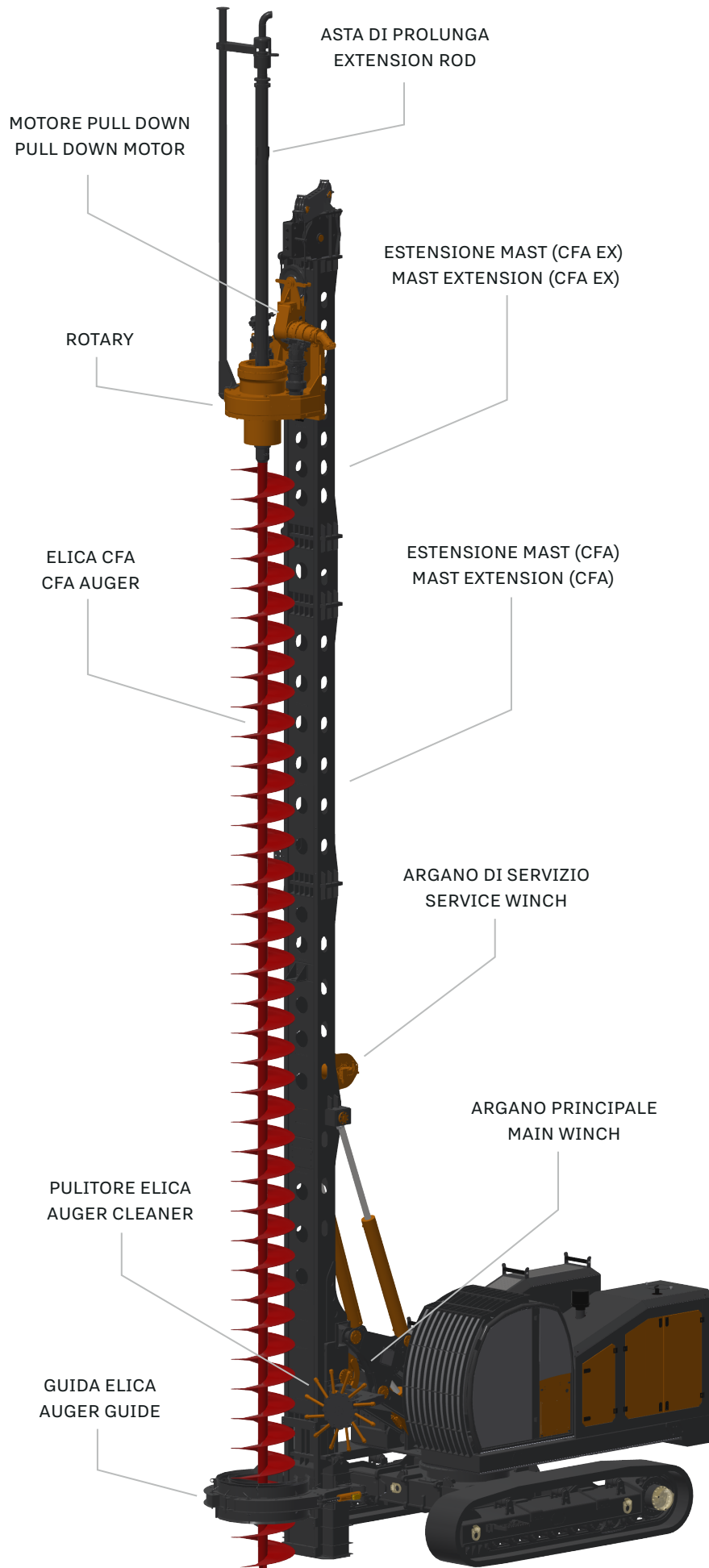

/ MR-P Line

MR-P 750 CFA

SISTEMA DI ESTRAZIONE EXTRACTION SYSTEM		MW (MOTOR - WINCH)	
Tipo Type	Typ Type	Combinato / Combined	
Forza di estrazione Extraction force	Extraktionskraft Force d'Extraction	22000 daN / 48.500 lbf	
Controllo Control	Kontrolle Control	Proporzionale / Proportional	
SISTEMA DI SPINTA (OPZIONALE) CROWD SYSTEM (OPTIONAL)		MPD (MOTOR PULLDOWN)	
Tipo Type	Typ Type	Motor Pulldown	
Forza di spinta Crowd force	Poussée Vorschubkraft	10000 daN / 22.050 lbf	
Controllo Control	Kontrolle Contrôle	Proporzionale / Proportional	
PERFORAZIONE DRILLING	BOHRUNG FORAGE	CFA	CFA EX
Diametro Max Max. diameter	Max. Durchmesser Max. Diamètre	1000 mm / 39,3 in	800 mm / 31.5 in
Lunghezza Elica Max. Auger length	CFA Maximale Länge CFA longueur maximale	9000 mm / 29,5 ft	13000 mm / 42,6 ft
Profondità Max (no EX) Max. depth (no EX)	Maximaltiefe (no EX) Profondeur max. (no EX)	8.5 m / 27.8 ft	12.5 m / 41 ft
Estensione Elica Auger extension	Max. CFA Verlängerung Max. CFA extension	4000 mm / 13.1 ft	
Profondità Max Max. depth	Maximaltiefe Profondeur maximale	12.5 mt / 41 ft	16.5 / 54 ft

MW SYSTEM

PULL UP SYSTEM
(Combined winch / motor)

PULL DOWN SYSTEM
(Motor - winch disengaged)

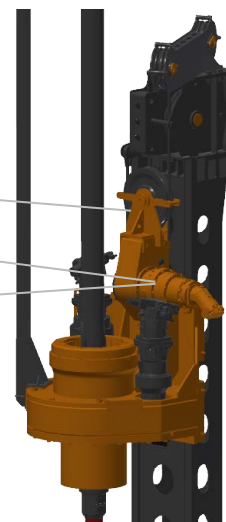

/ MR-P Line

MR-P 750 BP

DIMENSIONS	BP LH	BP
L	7280 mm / 23.9 ft	10570 mm / 34.7 ft
W	2550 mm / 8.3 ft	
H	3215 mm / 10.5 ft	

TRANSPORT DATA

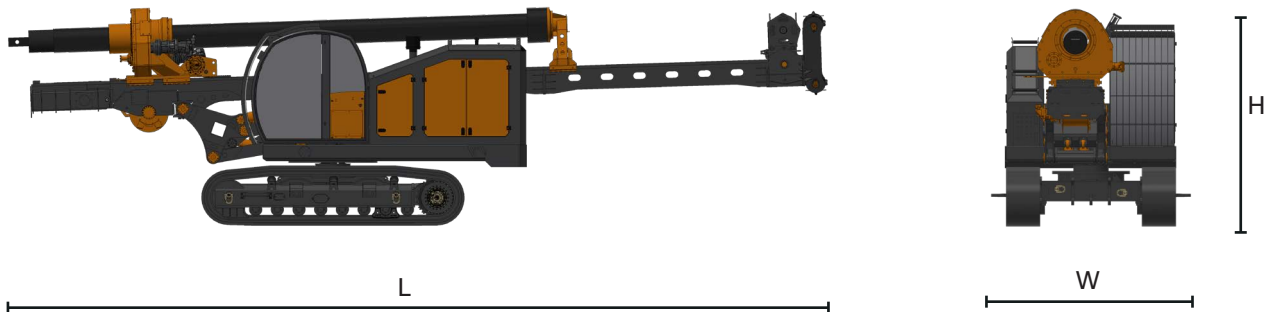

WEIGHT BP	BP LH	BP
MACCHINA BASE SENZA KELLY BAR E UTENSILE BASE MACHINE W/O KELLY BAR AND TOOL	24000 kg / 52910 lb	25000 kg / 55115 lb
CONTRAPPESO COUNTERWEIGHT	8 X 310 kg / 684 lb	
KELLY BAR 15 m / ft	2500 kg / 5511 lb	
KELLY BAR 22 m / ft	3200 kg / 7055 lb	
KELLY BAR 28 m / ft	3750 kg / 8270 lb	
KELLY BAR 32 m / ft	4200 kg / 9260 lb	

(*) Valori massimi variabili in base all'allestimento / max. values may vary according to the setup / valeurs variables en fonction de l'agencement



MR-P 750 CFA

DIMENSIONS	CFA	CFA EX
L	11760 mm / 38.6 ft	12090 mm / 39.7 ft
W	2550 mm / 8.3 ft	
H	3160 mm / 10.3 ft	

TRANSPORT DATA

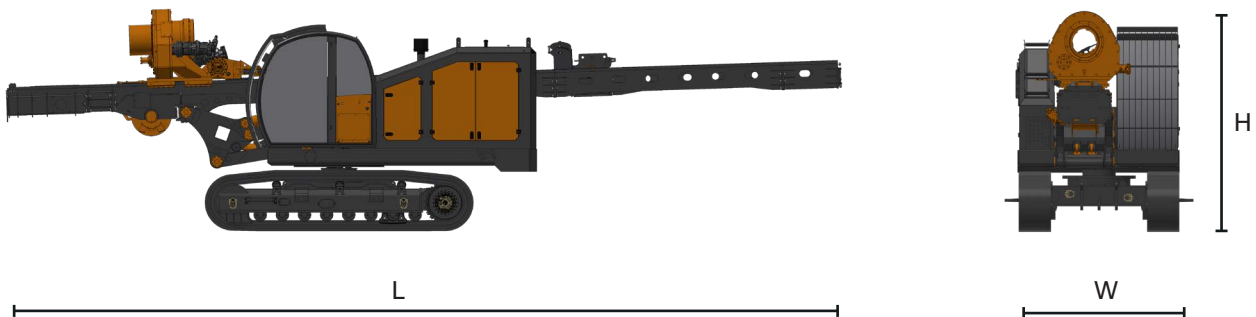

WEIGHT CFA	CFA	CFA EX
BASE MACHINE W/O TOOL MACCHINA BASE SENZA UTENSILE	26500 kg / 58425 lb	27500 kg / 60630 lb
CONTRAPPESO COUNTERWEIGHT	8 X 310 kg / 684 lb	
MAX TOOL WEIGHT (CFA) PESO UTENSILE MAX (CFA)	3600 Kg / 7940 lb	

(*) Valori massimi variabili in base all'allestimento / max. values may vary according to the setup / valeurs variables en fonction de l'agencement



MARINI SRL

Via Beura 44 - 28844 Villadossola (VB)

www.marinidrills.com



www.printgraficapistone.it