



NKD 125

EURO 5+



OWNER'S MANUAL



RIEJU S.A. would like to thank you for your trust in our company and congratulate you on an excellent choice.

The **NKD 125 E5+** model is the result of **RIEJU'S**, extensive experience in developing high-performance vehicles.

The purpose of this Owner's Manual is to set forth how to use and maintain your vehicle. We ask that you carefully read the instructions and information provided as follows.

Please remember that the vehicle's life cycle depends on how you use and maintain it. Keeping it in perfect operating condition reduces the cost of repairs.

Please consider this manual an integral part of the vehicle. It must remain with its basic equipment, even in the event of a change in ownership.

For any issues, please see your **RIEJU** dealer, who will be delighted to serve you, or visit:

www.riejumoto.es

Remember that for your vehicle to operate properly, you **MUST** always request original replacements.



TABLE OF CONTENTS

Important Notices	5	Oxygen Sensor	36
Safety information.....	7	EVAP emissions filter (activated carbon canister) .	37
Vehicle description	10	Side Stand	37
Vehicle registration.....	11	Inspections before riding.....	38
Vehicle delivery (complete upon first delivery)	12	Engine Starting	40
Inspection prior to delivery (Adjustments)	13	Gear Shift Lever	41
Technical info	16	Tire Pressure & Load	42
Location of Important Vehicle Labels	20	Tire Storage	43
Chassis identification number	20	Tire Condition & Specifications.....	43
Engine identification number	20	Engine Break-In	44
Main vehicle elements.....	22	Electronic Fuel Injection (EFI) System Diagnosis	45
Instrument dashboard.....	25	Safe riding	46
Ignition switch / Steering lock	29	Running-in	48
Component function description	31	Vehicle operation.....	50
Left Switch	31	Inspection and maintenance.....	54
Right Switch	31	Daily inspection	54
Clutch Lever	32	Changing Engine Oil (or with Oil Filter)	55
Rear Brake Pedal.....	33	Regular Maintenance	57
Front Brake Lever	33	Spark plug	58
Fuel Tank Cap.....	34	Engine Oil and Oil Filter	59
Fuel Tank.....	34	Selection of Engine Oil	59
Catalytic Converter	35	Checking Engine Oil Level	60
		Cooling system	61



Cooling System Inspection.....	63	Vehicle storage	81
Clutch Adjustment	63	How to reactivate the vehicle.....	83
Replacing the Air Filter	64	Vehicle protection	84
Throttle Cable Adjustment	65	Cleaning the vehicle	84
Brake System Inspection.....	66	Modifications and accessories.....	86
Rear Brake Adjustment.....	67	Warranty	87
Inspecting Front and Rear Brake Pads	67		
Checking Brake Fluid Level.....	68		
Transmission chain (adjustment and tension)	69		
Drive Chain Inspection	70		
Side Stand Inspection and Lubrication	71		
Front Fork Inspection	72		
Front Fork Inspection	73		
Front and Rear Wheel Bearing Inspection.....	73		
Battery Inspection.....	74		
Checking Battery Charge	74		
Battery Storage.....	75		
Fuse Replacement.....	76		
Troubleshooting Table / Starting Problems & Engine			
Performance Issues.....	77		
Maintenance Schedule.....	78		
Engine Overheating	80		
Vehicle storage and cleaning	81		



IMPORTANT NOTICES

These are the safety alert symbols. Always follow all safety messages that accompany these symbols to avoid possible injury or death.



WARNING:

Indicates that failure to follow the procedure described in this Owner's and Maintenance Manual could result in serious injury or death.



CAUTION:

Indicates that failure to follow the instructions in this manual may result in personal injury or damage to the vehicle.



TIP:

Additional information provided by Rieju.

**TIP:**

This instruction manual shall be regarded as a permanent component of the vehicle. When the vehicle is transferred to another party, please provide this manual together with the vehicle.

Our company continuously strives for ongoing improvements in product design and quality. Therefore, this manual contains the latest product data, instructions, specifications and images available at the time of printing, but there may be minor discrepancies with your motorcycle. Should you have any questions regarding this manual, please consult your local dealer. RIEJU,S.A. reserves the right to make changes at any time without prior notice, including modifications to parameters and other related details.

**WARNING:**

Please read this manual carefully and do not operate the motorcycle until you have mastered safe and proper riding skills. Regular inspections, careful maintenance and proficient riding skills will ensure safe control of your vehicle.

When installing or replacing the battery, pay close attention to the positive and negative polarity of the terminals. If reverse connection is found, check whether the fuse is intact. Regardless of the fuse condition, the motorcycle must be taken to an authorized service center for inspection to prevent electrical component damage caused by reverse battery polarity. If damaged components continue to operate, unpredictable faults may occur.

Before replacing the fuse, turn the ignition switch to the “OFF” position to prevent accidental short circuits.



SAFETY INFORMATION

Motorcycles are motor vehicles . Operating such vehicles requires a certain level of riding skill and relevant motorcycle knowledge . The dealer shall inform the rider of the following:

What the rider should know:

- Proficiency in operating all controls of the motorcycle.
- Pay attention to the warnings and maintenance information in the manual.
- Motorcycle riders must pass the examination by the traffic management department and obtain a valid driver's license before operating a motorcycle. Driving without a license is strictly prohibited.
- Some simple, basic motorcycle issues can be resolved by referring to the vehicle owner's manual.

Environmental Protection Tips: Used engine oil, coolant, gasoline, and some cleaning agents contain toxic substances and must not be discarded arbitrarily. Place these items in a dedicated sealed container and deliver them to a recycling center or the local environmental protection department for proper disposal. Do not dismantle or discard batteries on your own; these items must be recycled by the dealer or a professional institution. Scrap motorcycles should be sent to a local professional recycling center for disposal.

Prohibition on Modification: Unauthorized modification of motorcycles or arbitrary replacement of original factory parts is strictly prohibited. Any modification will seriously affect the stability and safety of the motorcycle, potentially leading to failure to operate normally. No unit or individual may assemble motor vehicles on their own or arbitrarily alter the original structure, configuration, or characteristics of the motorcycle. If the user carries out



unauthorized modifications or replaces original parts without permission, any resulting quality issues and consequences (including voiding of the warranty) shall be borne solely by the user.

Compliance with Regulations: Users are required to comply with the relevant regulations of the traffic management department regarding motorcycle usage.

Safety Reminder: After purchasing a motorcycle, please ensure you are equipped with a motorcycle helmet that complies with local laws and regulations.

Safe Riding:

- Before riding, carefully read the Pre-Ride Inspection section and inspect your motorcycle. This helps prevent accidents.
- This motorcycle is designed to carry only the rider and one passenger, for a maximum of two people.
- Due to its small size, motorcycles are often involved in accidents with automobiles because they are harder to see.

Therefore:

- Wear bright , high-visibility clothing. The rider must use motorcycle-specific apparel and protective gear, and passengers should dress in a compact , secure manner.
- When approaching intersections — Accident-prone areas — pay extra attention to other vehicles and ensure you are visible to other drivers.



- While riding, stay within the field of vision of other motorists and avoid their blind spots.
- Maintain a safe distance from other vehicles, use turn signals, horns, and other signaling devices correctly, never overtake aggressively, and strictly observe all traffic rules.



VEHICLE DESCRIPTION

This motorcycle has a four-stroke single-cylinder injection engine with water cooling. Its cubic capacity is 125 cubic centimetres, with a 58-mm diameter piston with 47 mm movement.

Steel and friction multi-plate clutch with constant pressure springs, immersed in oil bath.

The engine is anchored to a highly resistant backbone chassis, with cone roller bearings.

The front suspension is a hydraulic mechanical fork with 41-mm diameter bars. Rear suspension is a hydraulic mechanical shock absorber that provides gentle operation.

The front and rear brakes are stainless steel disc brakes. The front measures 320 mm and the rear 240 mm.



VEHICLE REGISTRATION

Please make a note of the chassis and engine serial numbers, which will help you for all purposes (certificate of characteristics, insurance, registration, etc.).

These numbers will be useful for you for any suggestions or complaints, as well as to order replacement parts.

Chassis serial number (p.20)

Engine serial number (p.20)

Dealer seal



VEHICLE DELIVERY (complete upon first delivery)

- USER MANUAL**
Explain the importance of reading it and understanding all the information. Highlight the sections on safety and maintenance practises.
- WARRANTY REGISTRATION CARD**
Fill out all necessary information and provide a copy to the client.
- HANDLING**
Explain how to properly handle the vehicle.
- WARNINGS**
Explain the importance of the warnings to guarantee a long “life” for the vehicle.
- KEYS**
Deliver the complete set. Advise them to make a backup copy of the set.
- FIRST INSPECTION**
Explain that an inspection after 1,000 km is important.
- PERIODICAL MAINTENANCE**
Explain the need for periodical maintenance and state that failure to comply with guidelines for check-up and visiting the shop is grounds for “Loss of Vehicle Warranty.”



INSPECTION PRIOR TO DELIVERY (Adjustments)

- General appearance**
- Engine**
- Engine oil level
- Chassis**
- No fuel leaks in: Tank output, fuel tap, and supply lines
- Front and rear brake - Drain, if necessary
- Coolant level
- Front, rear mudguard and attachment elements
- Wiring of electrical installation around the steering column
- Alignment of front, rear wheels, and tightening torque of wheel axles
- Tyre pressure
- Chain tension
- Checking the equipment**
- Accelerator works and has free play. Adjust if necessary
- Degrease both brake discs
- Battery charged and terminals greased
- Steering lock or anti-theft lock
- Electric start-up engine operation
- Clutch cable properly adjusted



- Operation of fuel cap closure
- General inspection of nuts and screws: Callipers/discs, transmission/pinions, wheel nuts, tilt, engine mounts, exhaust system, shock absorber, gear selector, brake pedal/levers, manifold nuts, etc.
- Fuel tank**
- Check that the tank is not in contact with the frame
- Driving components**
- The digital instrument dashboard checks itself when the ignition is turned on
- Adjusting the headlight height
- Brake light when pressing brake levers LH and RH
- Front, rear blinkers and mounting clips
- Horn operation
- ON-ROAD TEST, at least 10 km**
- Engine and gearbox operation
- Grip on road and suspensions
- No abnormal sounds
- Braking and ABS operation



AFTER ON-ROAD TEST

- Coolant leaks
- Fuel system, including hoses, clips, and all associated parts where leaks may appear

CHECKING FINAL APPEARANCE

Date

Manufacturer signature



Technical info

GENERAL INFORMATION	
Length	2006 mm
Width	780 mm
Height	1100 mm
Wheelbase	1376 mm
Ground Clearance	150 mm
Curb Weight	150 kg
Frame	
Type	Backbone
Steering Head Angle	32 °
Front Tire	
Type	Tubeless
Specification	110/70-17
Rear Tire	
Type	Tubeless
Specification	140/70-17
Maximum Load	Capacity: 289 kg - *(Includes rider, passenger, luggage , and accessories)



Tire Pressure Front	250 kPa
Tire Pressure Rear	250 kPa
Front Wheel Hub	
Material	Light Alloy Casting
Specification	3.0* 17
Rear Wheel Hub	
Material	Light Alloy Casting
Specification	3.75* 17
Front Brake	
Type	Disc, hydraulic
Operation	Right Hand Lever
Recommended Brake Fluid	DOT 4
Rear Brake	
Type	Disc, hydraulic
Operation	Right Foot Pedal
Recommended Brake Fluid	DOT 4
Front Suspension	
Type	Inverted Telescopic Fork
Operation	Spring / Hydraulic



Rear Suspension	
Type	Monoshock
Operation	Spring/Hydraulic

ENGINE	
Type	4-Stroke, DOHC
Cooling	Liquid-Cooled
Cylinders	Single Cylinder
Displacement	124.18 ml
Bore × Stroke	58 mm × 47 mm
Compression Ratio	12.4:1
Starting Method	Electric Start
Engine oil	
Grade	10W/40
Cooling System	
Radiator Capacity	1000 ml
Air filter	
Type	Paper



ELECTRICAL SYSTEM	
Ignition	Electronic Ignition
Charging	AC Generator
Battery	
Voltage / Capacity	12V / 8Ah
Lamps	
Headlight	LED , CC12V
High Beam	19W / Low Beam: 10W
Tail / Brake Light	LED , DC12V
Front Turn Signals	1.65W / 2.5W
Rear Turn Signals	LED , DC12V, 1W
Position Light	LED , DC12V, 1W
License Plate Light	LED , DC12V, 0.5W
Instrument Panel Light	LED , DC12V, 1W
High Beam Indicator	LED
Engine Fault Warning Light	LED , DC12V
ABS Warning Light	LCD
Main Fuse	LCD Fuses
Lighting Fuse	10A
EFI Fuse	15A
ABS Fuse	10A



LOCATION OF IMPORTANT VEHICLE LABELS

Chassis identification number

This is the number (1) that is die-cut on the right of the steering tube.

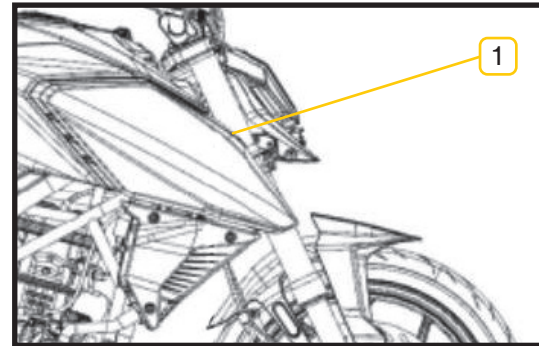

Engine identification number

This is the number (1) that is marked on the bottom of the engine's left crankcase half.

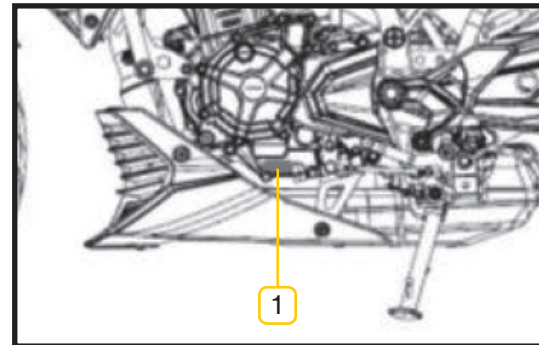



Builder label

Your **RIEJU** has an identification plate (1) with details on: manufacturer, frame number, approval number, and sound emissions level. The frame number is also die-cut on the right side of the steering tube.

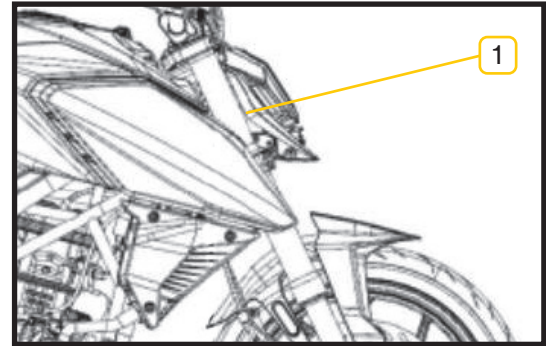

Fuel level

Maintain sufficient fuel in the fuel tank. If the fuel tank runs out of fuel, the fuel pump will run empty and could be damaged. Use unleaded gasoline with an octane rating of 92 or higher.

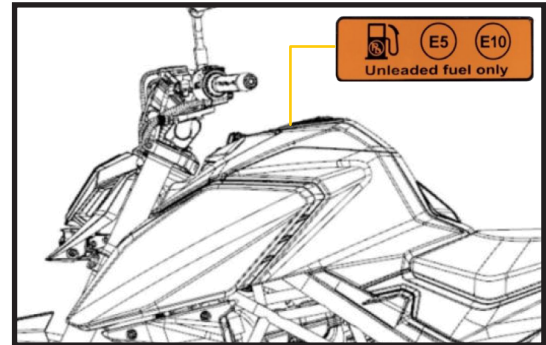



MAIN VEHICLE ELEMENTS

1. Rear Disc Brake
2. Muffler
3. Rear Brake Pedal
4. Engine Oil Filler Cap
5. Oil Filter
6. Front Disc Brake

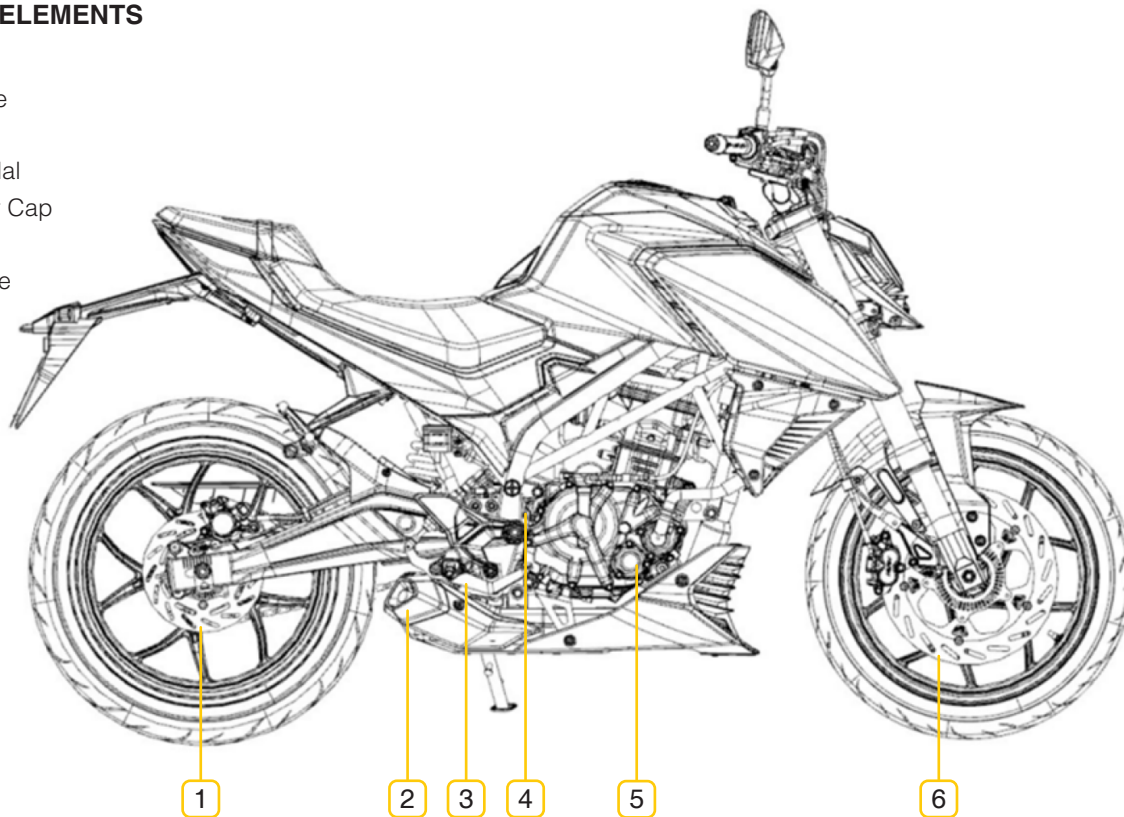



- 7. Oxygen Sensor
- 8. Gear Shift Lever
- 9. Side Stand
- 10. Air Filter
- 11. Rear Shock Absorber
- 12. Chain Adjuster
- 13. License Plate Bracket

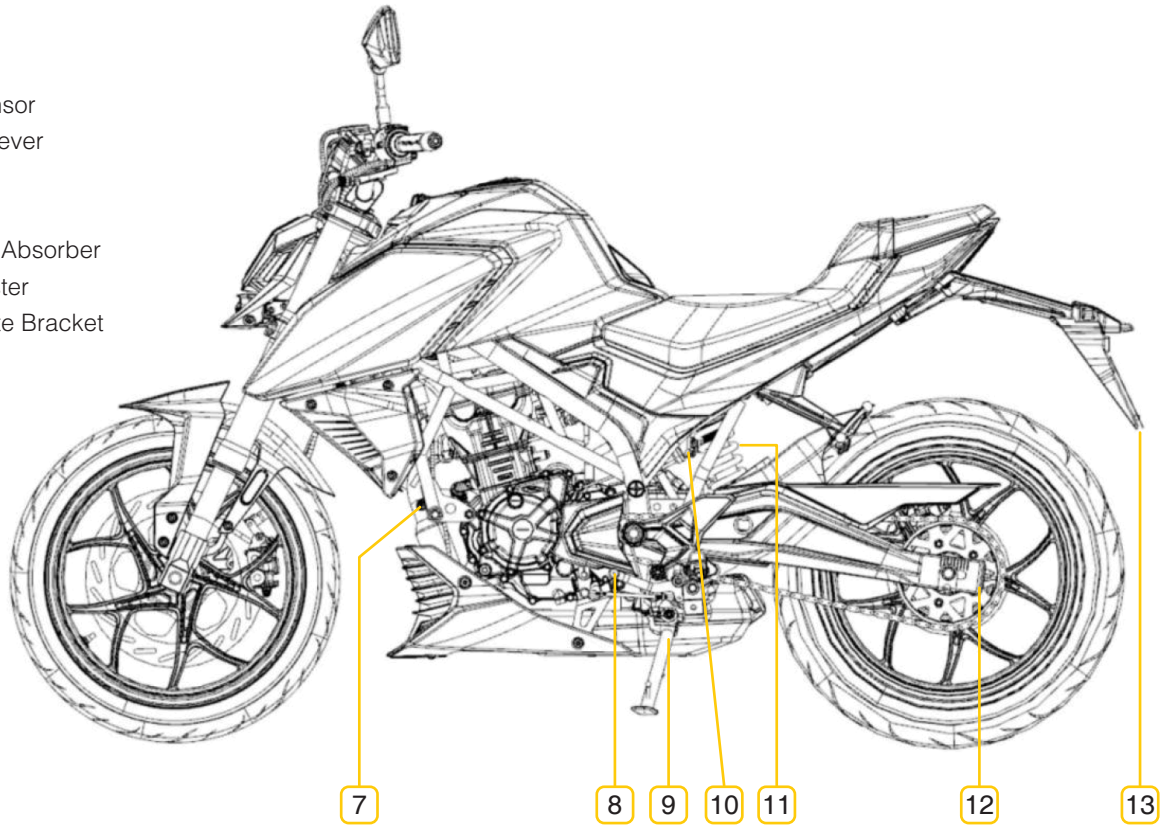

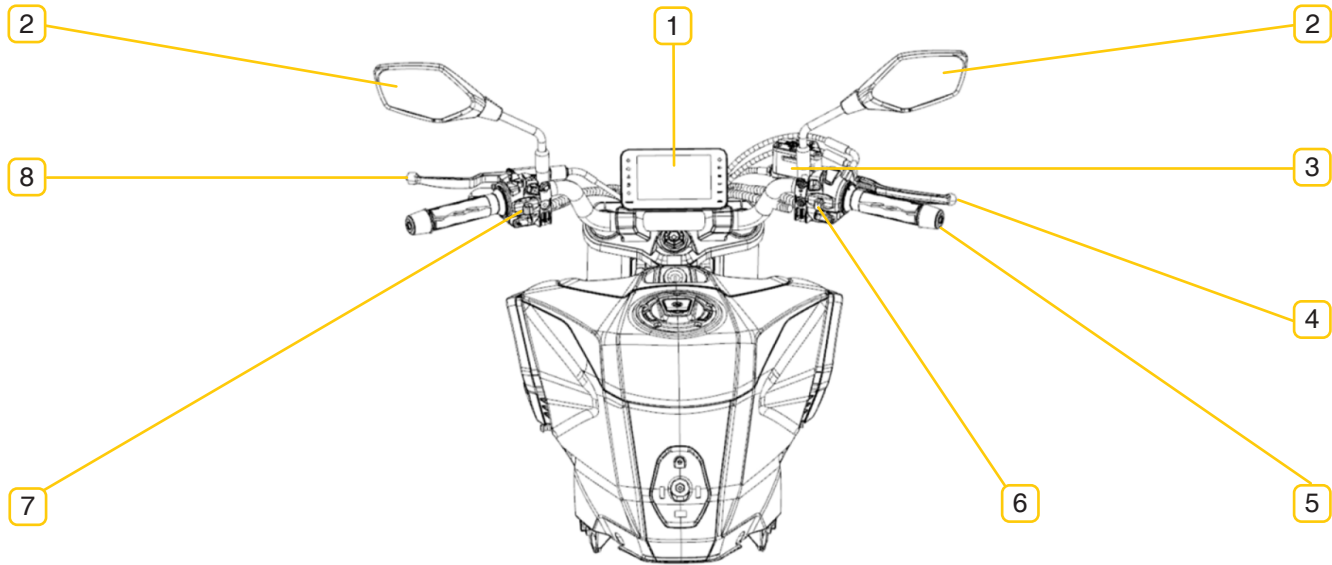

- 1. TFT Display Instrument
- 2. Rearview Mirror
- 3. Front Brake Fluid Reservoir

- 4. Front Brake Lever
- 5. Throttle Grip
- 6. Right Handlebar Switch

- 7. Left Handlebar Switch
- 8. Clutch Lever



INSTRUMENT DASHBOARD

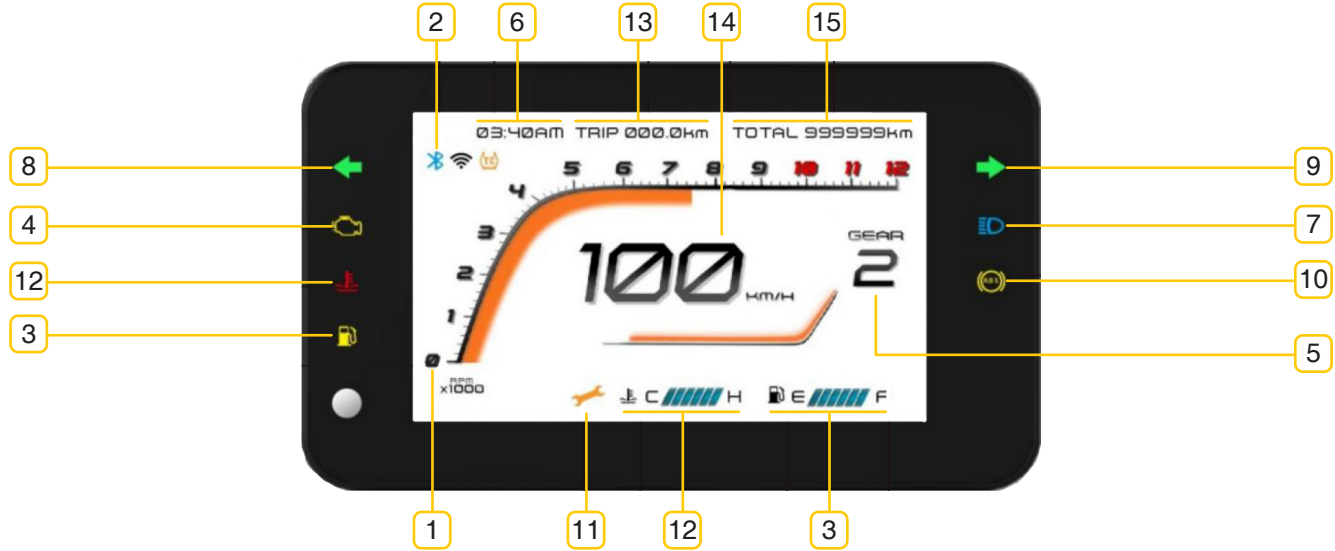

1. Tachometer

2. Bluetooth

3. Fuel Level Indicator

4. EFI (Electronic Fuel Injection) Warning Light

5. Gear Position Indicator

6. Clock

7. High Beam Indicator

8. Left Turn Signal Indicator

9. Right Turn Signal Indicator

10. ABS Warning Light

11. Maintenance Reminder Light

12. Water Temperature Indicator

13. Trip Meter

14. Speedometer

15. Odometer

**WARNING:**

Do not use a high-pressure water gun to directly wash the instrument. Under no circumstances should you wipe the instrument with a cloth soaked in gasoline, kerosene, alcohol, brake fluid, or other organic solvents, as this may cause localized cracking or discoloration of the instrument due to contact with the solvent.

- 1 Tachometer (Displays engine RPM).
- 2 Bluetooth Function
- 3 Fuel Level Indicator (Displays the remaining fuel in the tank. Refuel as soon as possible if the fuel level light flashes.)

**CAUTION:**

Maintain sufficient fuel in the fuel tank. If the fuel tank runs dry, the fuel pump will run empty and may be damaged.

- 4 EFI Warning Light (Illuminates when the vehicle is powered on and turns off after the engine starts. If the light remains on after the engine starts, it indicates an EFI system fault. Do not ride the vehicle. contact an authorized service center immediately.)
- 5 Gear Position Indicator (Displays the current gear of the vehicle).
- 6 Clock Display (Displays time in 12/24-hour format).



- 7 High Beam Indicator.
- 8 Left Turn Signal Indicator.
- 9 Right Turn Signal Indicator.
- 10 ABS Warning Light (Illuminates when the vehicle is powered on and started, and turns off automatically when the speed reaches 5 km/ h. If the light does not turn off, it indicates a fault. Do not continue riding; contact a Rieju Service Center immediately.).

**WARNING:**

If the ABS warning light:

- Does not illuminate when the vehicle's power is turned on.
- Flashes or remains on while riding.

The ABS system may be faulty. Please visit an authorized service center for inspection and repair.

- 11 Maintenance Reminder Light: Illuminates when the engine maintenance mileage is due. Please visit an authorized service center for inspection and maintenance.
- 12 Water Temperature Indicator.

**CAUTION:**

The coolant temperature gauge displays the temperature of the coolant , which varies with weather conditions and engine load. If the water temperature warning light flashes , stop the vehicle immediately and allow the engine to cool down .



- 13 Trip Meter (Displays short-distance mileage).
- 14 Speedometer (Displays current vehicle speed).
- 15 Odometer (Displays total accumulated mileage).



IGNITION SWITCH / STEERING LOCK

Ignition lock (1)

The ignition switch controls ignition, lighting systems, and the steering lock. Details are as follows:

All electrical circuits, instruments, taillights, auxiliary lights, position lights, etc., are active, and the engine can be started at this time.

Main Power On

After unlocking with the key and activating the ignition switch, all electrical circuits, instrument lighting, taillights, and auxiliary lights are active. The engine can then be started via the ignition button on the handlebar switch.



TIP:

When the main power is turned on, the running lights activate automatically. After the engine starts, the headlight turns on automatically (with high/ low beam switching); when the engine is turned off, the headlight turns off automatically. When the ignition switch is turned off, the running lights turn off automatically.

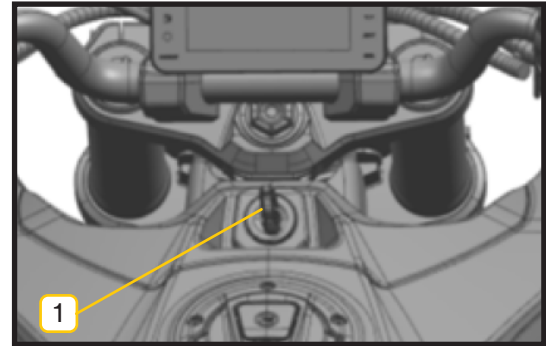



Main Power Off

All electrical circuits will be shut down.

Steering Lock

Locks the steering mechanism. With the steering mechanism locked, the key can be removed.

Enabling the steering lock (2)

- 1- Turn the handlebar all the way to the left.
- 2- Turn the key clockwise to unlock the steering.
- 3- Turn the key counter-clockwise to lock the steering.



WARNING:

Never remove the key or turn off the power while the vehicle is in motion. Doing so will shut down the electrical system, which may cause loss of vehicle control and lead to an accident.

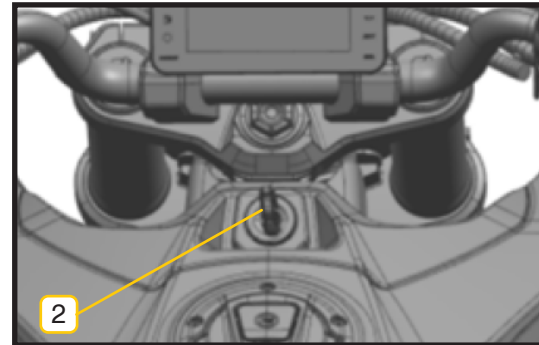



COMPONENT FUNCTION DESCRIPTION

Left Switch

1. Horn Button.
2. High/ Low Beam Switch.
3. Left/ Right Turn Signal Switch.
4. Passing Light Switch.
5. ENTER Button.
6. SELECT Button.

Operation of ENTER and SELECT Buttons:

On the Main Screen.

Short press ENTER to enter the main menu.

Long press ENTER to enter the connectivity interface.

Long press SELECT to reset the trip meter.

In the Main Menu.

Short press ENTER to confirm.

Long press ENTER to return to the previous menu.

Short press SELECT to select an option.

Right Switch

1. Engine Stop Switch.
2. Hazard Light Switch.
3. Ignition Switch.

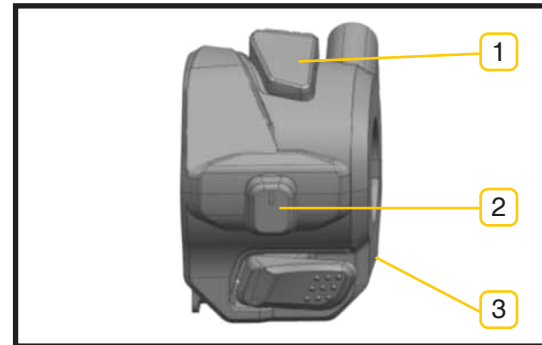
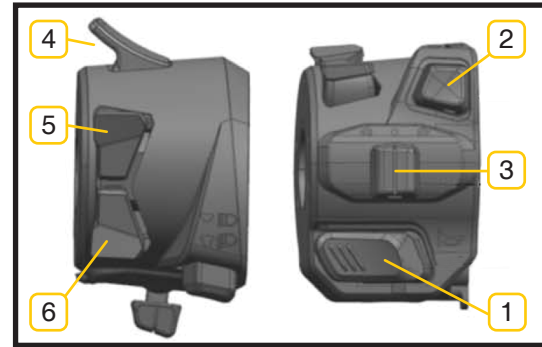



Clutch Lever

When starting the engine or shifting gears, squeeze this clutch lever (1) to disengage the friction plates and interrupt power transmission.

The free play of the clutch lever should be between 10 and 20 mm.

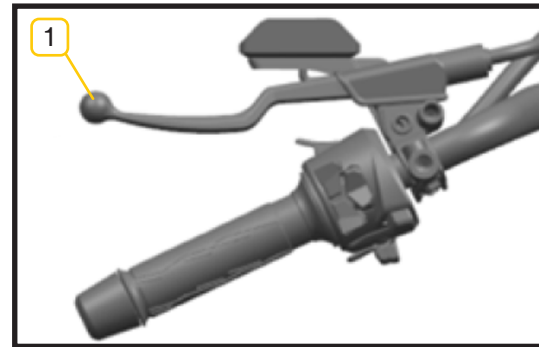

This vehicle is equipped with a 6-speed gear transmission. Shift gears by pressing the gear shift lever downward or lifting it upward; the lever will automatically return to its original position. Before shifting to a lower gear, reduce the vehicle speed or increase the engine speed. Before shifting to a higher gear, increase the vehicle speed or decrease the engine speed. This prevents unnecessary wear on the transmission system components and the rear tire.

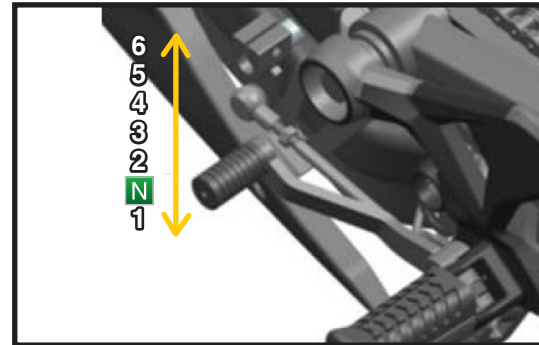



Rear Brake Pedal

The rear brake pedal is located on the right side of the vehicle body, next to the engine. To apply the rear brake, press down on this pedal (1). The rear brake pedal is equipped with an adjustment bolt to adjust its free travel. Adjust the bolt to maintain the proper pedal travel.

When the brake pedal is in the rest position, it should have a 10-15 mm play.

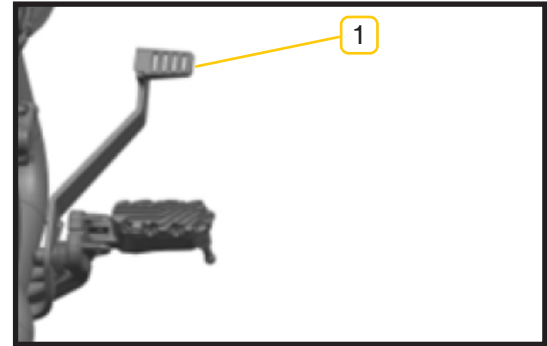

Front Brake Lever

The front brake lever is located on the right side of the handlebar. To apply the front brake (1), grip this lever.

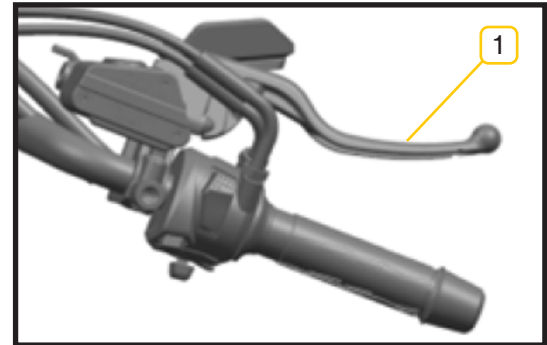



Fuel Tank Cap

To open the fuel tank cap, insert the key and turn it counter-clockwise; the cap will pop up automatically.

To close the fuel tank cap, press it down firmly until you hear the sound of the latch engaging, then remove the key.

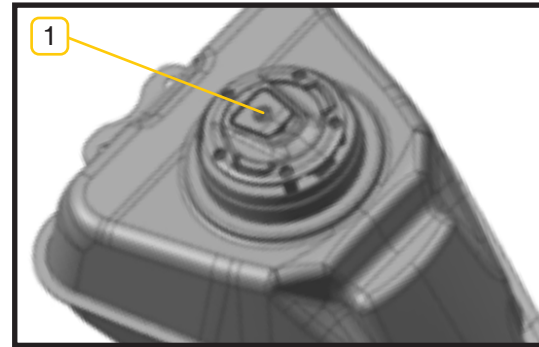

Fuel Tank

Your NKD 125 motorcycle is designed to run on premium unleaded gasoline with an octane rating of 95 or higher. Using unleaded gasoline will extend engine life and reduce maintenance costs.

RECOMMENDED FUEL

Unleaded gasoline with an octane rating of 95 or higher

TANK CAPACITY

13.5 L

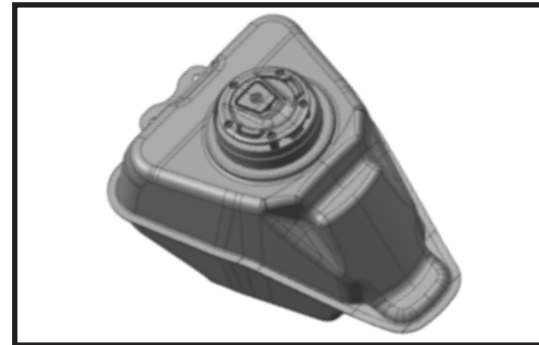



Catalytic Converter

This vehicle is equipped with an exhaust muffler that incorporates a catalytic converter.



WARNING:

The exhaust system becomes very hot when the engine is running. Always ensure the exhaust muffler has cooled down before performing any maintenance to avoid burns.



CAUTION:

To prevent fire or other damage, the following precautions must be strictly observed:

- Only use unleaded gasoline. Using leaded gasoline will cause irreversible damage to the catalytic converter.
- Do not park the vehicle near any potential fire hazards.
- Do not let the engine idle for an extended period.



Oxygen Sensor

This vehicle is equipped with two oxygen sensors (1) to reduce exhaust pollutants generated by the exhaust gas.

This vehicle uses a fuel pump to supply fuel. When the ignition switch and kill switch are turned on, the fuel pump will run for 2–3 seconds and then stop. Once the engine is started, the fuel pump will operate continuously. If the fuel runs out, the pump will run dry, which can cause damage. Pay attention to the fuel gauge reading and refuel before the tank is empty.

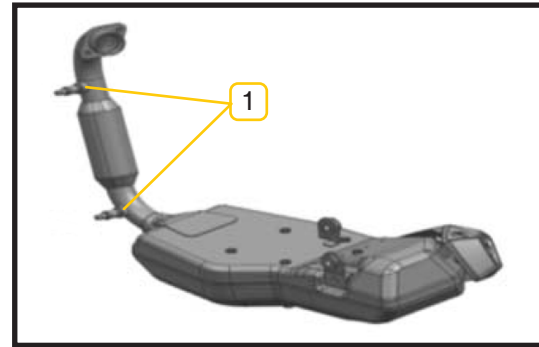

CAUTION:

- Use only unleaded gasoline with an octane rating of 95 or higher. Using poor-quality gasoline will damage the electronic fuel injection (EFI) system.
- When the fuel pump is operated for the first time, ensure there is sufficient fuel in the tank. Do not run the pump without fuel. The fuel pump assembly is designed for gasoline fuel only.



EVAP emissions filter (activated carbon canister)

This vehicle is equipped with an activated canister to prevent fuel vapors from being released into the atmosphere. Inspect the canister at the specified mileage or time intervals. Check the condition of all connecting hoses, and inspect the hoses and canister for cracks or damage. Replace any damaged components. Ensure the hoses are not clogged and clean them as needed.



Side Stand

The side stand is located on the left side of the vehicle. When using it keep the motorcycle up and lower or raise the stand with your foot.



WARNING:

Do not ride the motorcycle if the side stand is down or cannot be retracted. The stand will contact the ground, distracting the rider and leading to loss of control.





Inspections before riding.

Failing to properly inspect and maintain your motorcycle before riding increases the risk of accidents and vehicle damage. A pre-ride inspection is mandatory every time you use the motorcycle to ensure it is safe to operate. Refer to the Inspection and Maintenance sections of this manual for details . Using improper tires, operating the motorcycle incorrectly, or riding with incorrect tire pressure will result in loss of control. Always use tires of the specified size and rating, and maintain proper tire pressure as outlined in the Inspection and Maintenance.

1. Engine Oil Level: Check the engine oil level and add oil as needed.
2. Fuel Leakage: Inspect for any fuel leaks .
3. Brakes: Check the operation of the front and rear brakes . Adjust if the free travel is too large or too small, and inspect for seizure or poor braking performance.
4. Tires: Check the tire pressure and tread wear of the front and rear tires. Inflate or repair as necessary.
5. Throttle: Inspect the throttle grip operation, the condition of the control cables, and the free travel. Adjust or replace as needed.
6. Lights & Signals: Verify that the headlight, taillight, turn signals, and horn are functioning properly. Adjust or repair as needed.
7. Chain: Check the tension and wear of the drive belt. Replace if excessively worn or damaged.
8. Steering: Inspect the steering mechanism for smooth operation and stability. Adjust if necessary.
9. Engine: Check the engine for any abnormalities.
10. Instruments: Ensure all indicators and gauges are functioning correctly. Correct any issues as needed.
11. Fasteners: Confirm that all bolts and fasteners are tight. Retighten as necessary.
12. Side Stand Kill Switch: Verify that the side stand cut-off system is functioning properly. If not, contact your Rieju motorcycle.

**TIP:**

Never underestimate the importance of these inspections. Complete all checks and perform any necessary repairs before riding.

**WARNING:**

Performing inspections while the engine is running is dangerous. Your hands or clothing could be caught in moving parts, resulting in serious injury. Turn off the engine for all inspections except when testing the engine kill switch and throttle operation.

**WARNING:**

- If you are riding this type of motorcycle for the first time, we recommend practicing on a non-public road until you are familiar with its controls and handling.
- Riding with one hand is dangerous. Always grip the handlebars firmly with both hands and keep your feet on the footrests when riding. Under no circumstances should you ride with both hands off the handlebars.
- Reduce your speed to a safe level before turning.
- When the road is wet or slippery, tire friction is reduced, which naturally impairs braking and cornering performance. Therefore, you must slow down in advance.
- Crosswinds are most likely to occur at tunnel exits, in mountain valleys, or when large vehicles overtake from behind. Remain calm and reduce your speed.
- Obey all traffic rules and speed limits.



Engine Starting

Turn on the main power supply and check that the engine kill switch is in the OFF position. When the motorcycle is in neutral, the neutral indicator light on the instrument panel will illuminate.



WARNING:

Make it a habit to start the engine with the transmission in neutral, the throttle fully closed, and the clutch lever pulled in. This prevents the motorcycle from lurching forward accidentally. The engine will only start if the clutch lever is pulled in or the transmission is in neutral. Remember to retract the side stand before riding. Do not start the motorcycle if it is low on fuel or engine oil.



WARNING:

At high speeds, braking distance increases significantly. Maintain a safe following distance while riding. Using the front or rear brake alone is dangerous, as it can cause the vehicle to skid and lose control.



Gear Shift Lever

The engine has 6 gears, following the international standard:

press down to shift into first gear, then lift up to shift into second gear and higher. Refer to the diagram above for gear positions. Press or lift the shift lever to select the appropriate gear.



CAUTION:

When the gear is in neutral and the neutral indicator light is illuminated, gently release the clutch lever to confirm that the transmission is truly in neutral.

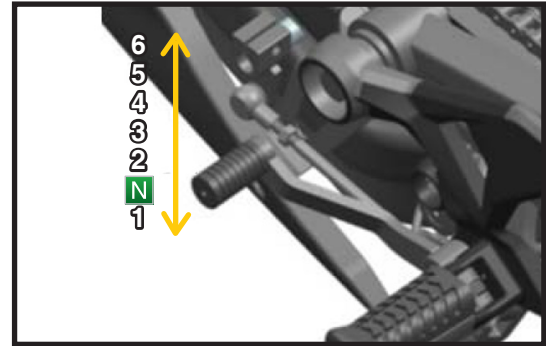



Tire Pressure & Load

Correct tire pressure and load are essential. Overloading can cause tire failure and loss of vehicle control . Check tire pressure before each ride; pressure increases when tires heat up during riding , so adjust accordingly.

Underinflation causes difficult cornering and accelerated tire wear. Overinflation reduces tire contact with the road , increasing the risk of skidding and loss of control. Recommended cold tire pressure: 250 kPa.



WARNING:

- Failure to observe the following precautions may lead to tire failure and accidents . Tires are the only contact point between the motorcycle and the ground , making them critical to safety.

Follow these rules:

- Inspect tire condition and pressure before each ride, and adjust pressure as needed. Never overload the motorcycle.
- Replace tires when tread is worn to the wear limit, or when cracks or damage are visible. Always use tires of the specified size and rating as outlined in this manual.
- Carefully read this section of the manual. Poor tire condition can cause slippage and loss of control. Exercise extreme caution when riding with new tires.



WARNING:

Check tire pressure regularly and maintain it within the recommended range. If you notice a drop in pressure, inspect the tire for nails, punctures, or damage to the rim bead, and check the valve stem for leaks.



Tire Storage

When the motorcycle will not be used for an extended period, adjust the tire pressure to the specified level. Tires are made of semi-vulcanized rubber and should not be stored outdoors at temperatures below freezing, as this can cause cracking and product failure. Store tires in a location with a consistent temperature, preferably indoors.

Tire Condition & Specifications

Incorrect tire condition or specifications will compromise motorcycle performance. Damage to the tire can lead to sudden deflation and loss of control. Excessive wear alters tire shape and handling characteristics.

Inspect tire condition and pressure before each ride. Replace tires if they show significant damage, cuts, or are worn to the wear limit indicator.



TIP:

When replacing tires, ensure the new tires meet the size and specifications listed below. Installing tires of incorrect size or type will affect handling and may lead to loss of control.

We strongly recommend using only standard-specified tires.

Front Tire	Rear Tire
110/70-17	140/70-17



Engine Break-In

Although engine components are made of high-quality materials and manufactured to advanced standards, proper break-in of all moving parts is essential before full-load operation. The engine's long-term performance and durability depend on careful break-in and maintenance during this initial period. During break-in, avoid high engine speeds when starting or riding. Do not accelerate abruptly, as this can subject the powertrain to shock loads and compromise break-in quality. After starting the engine, warm it up at low speed before moving off. Ride at reduced speed for the first 1–2 km, then resume normal riding.

Follow the engine speed limits in the table below for the break-in period.

Mileage (km)	Throttle (%)	Engine Speed (r/min)
First 500 km (brake-in)	≤ 30	≤ 4,500
Between 500 and 1,000 km	--	≤ 7,000



TIP:

After the break-in period, perform a maintenance service: tighten all fasteners and re-adjust components to ensure optimal performance and extend engine life.

If any issues arise during the break-in period, contact your Rieju motorcycle dealer or service center immediately.



WARNING:

- When the engine is turned off, the engine and exhaust pipe remain very hot. Park the motorcycle in a location where pedestrians and children cannot come into contact with these hot components to avoid burns.
- Do not park the motorcycle on slopes or soft ground, as this can cause it to tip over and increase the risk of fire from fuel leakage.
- Do not park the motorcycle on dry grass or near other flammable materials.



Electronic Fuel Injection (EFI) System Diagnosis

- Before installing a new battery, check that the connectors of the EFI (Electronic Fuel Injection) components' wiring harnesses are securely fastened, including the oxygen sensor, and ensure that gasoline has been added.
- When installing the battery, use a tool to firmly fasten the cables to the positive and negative terminals of the battery. Do not tighten them by hand.
- Maintain at least 3 liters of fuel in the fuel tank, otherwise the EFI system may not operate normally. Refuel promptly when the fuel level is at or below 1 bar.



WARNING:

- For new vehicles or vehicles that have run out of fuel, do not turn on the kill switch until fuel has been replenished. Otherwise, the fuel pump will run dry, which will seriously affect the service life of the fuel pump.
- If the fault light does not illuminate while the engine is running but flashes after the engine is turned off, it is a historical fault that has no impact on the entire vehicle and will disappear automatically over time.

If the yellow malfunction indicator light on the instrument panel illuminates while the engine is running, it indicates a fault in the electronic fuel injection (EFI) components that requires diagnosis and repair.

For scenarios such as battery reinstallation, power loss during riding, battery sleep restart, idle speed abnormality, or fuse removal/ installation, perform an EFI hardware reset as follows:

1. Turn on the ignition switch and engine kill switch.
2. Pull in the clutch lever, shift to neutral, and start the engine .After 10 seconds, turn off the engine kill switch.
3. After another 10 seconds, turn the engine kill switch back on.
4. Repeat this procedure twice.



SAFE RIDING

Before riding

1. Do not ride after taking medication or when not concentrated.
2. Inspect the motorcycle before starting your trip.
3. Wear a helmet and light-coloured, close-fitting clothing, along with any other protective body gear.
4. Do not drive if you feel unwell.
5. Do not ride under the influence of alcohol, drugs or without a driving license.

While riding

1. Ride smoothly, stay calm, and give your full attention to the road.
2. Maintain a steady speed and keep to the right-hand side.
3. Pay close attention at junctions. Proceed only when safe to do so.
4. Activate the blinkers before overtaking or changing lanes; complete the manoeuvre only after confirming it is safe and maintain an appropriate distance from other vehicles and pedestrians.



5. Due to reduced visibility, reduce your speed when riding at night.
6. Do not brake unnecessarily or change lanes frequently.
7. To prevent accidents, avoid sudden braking or acceleration.
8. Reduce your speed before turning to prevent skidding.
9. When the road surface is wet after rain, braking distances are increased. Under such conditions, ride slowly and brake gently.
10. If you notice any irregularities while riding, stop the motorcycle and check them immediately.

When parking

1. Turn the ignition to OFF and lock steering.
2. Park in a stable area with the side stand.
3. Check for fuel, oil, or coolant leaks.
4. Keep the motorcycle away from fire and do not smoke near it.



RUNNING-IN

Engine operation

Whether hot or cold, the engine should have sufficient idling time before starting to ensure that the oil circulates to all lubricated parts.

During the running-in, the engine speed must not exceed 4,500 r/min for the first 500 km, and must not exceed 7,000 r/min between 500 and 1,000 km.

Throughout the running-in, both gear and engine speed should be changed frequently, and the motorcycle should not be ridden continuously for long periods at a fixed gear and speed.

When the engine operates for a prolonged time at a constant low speed during the running-in period, component wear increases. As such, do not ride at a steady low speed for long periods.

During running-in, avoid sudden acceleration and braking except in emergencies.

Do not drive while dragging the gear. Anticipate deceleration in advance and keep the engine running smoothly at all times.

Avoid long-distance riding during the running-in period to allow the engine enough time to rest.



The running-in period has a major influence on the vehicle's service life and fuel consumption, so read the manual carefully before use. (During the first 500 km, correct vehicle operation will ensure performance so you can enjoy your riding experience.)

Tyre running-in

The new tyre's surface is smooth. Riding at high speed can easily lead to dangerous situations. For maximum tyre grip, the running-in process is essential.

During the first 200 km, you may run in the tyres by taking corners at low speed until all edges of the tread are fully worn in.

A raised area on the tyre tread poses an accident risk. The way to prevent such bulging is through proper tyre running-in.

Brake system running-in

During the initial 500 km, the new brake discs remain in their original state, so they have not yet reached their optimal friction level. To compensate reduced braking efficiency, apply slightly greater pressure to the brake lever.



CAUTION:

- When running a new vehicle, you must vary the engine speed from time to time. Do not ride continuously at a fixed speed. The purpose is to subject the components to stress so they can fully adapt, but without applying excessive load.



VEHICLE OPERATION

Pre-ride inspection

If you do not inspect the vehicle before riding, the likelihood of accidents and damage increases. Pay attention to the following elements:

Steering system

- The handlebar turns smoothly without sticking.
- The steering column does not move or feel loose.

Throttle

- The throttle cable has the correct amount of free play (2-6mm).
- The throttle operates smoothly without sticking.

**Brake**

- The brake lever and brake pedal operate normally.
- The brake fluid level is correct in the brake fluid tank.
- You can clearly feel the pressure point when braking.
- The brake disc and friction pads must be free from water and oil stains.

Shock absorber

- Press to ensure it returns smoothly.

Transmission chain

- There is no excessive wear or damage.
- The chain tension is correct.



Tyre

- The tyre pressure is correct.

- The tread depth is not excessively worn.

- The tread surface is free from cracks or cuts.

Engine oil

- The oil level is correct.

Cooling system

- The coolant level is correct.

- There are no coolant leaks.

Lighting

- Dipped beam / front position light, taillight / brake light, blinkers, headlamp, and instrument illumination all function normally.



Light indicators

- The high beam, neutral, and blinker indicators controlled by the brake lever switch operate correctly. The oil pressure warning lamp, engine malfunction indicator lamp, water temperature warning lamp, and oil level warning lamp do not flash or illuminate after the engine is started.

Horn

- Operates correctly.

Engine kill switch

- Operates correctly.

Side stand

- Can be retracted and deployed normally.

Rear-view mirrors

- With the vehicle in vertical position, objects located within 10 m behind and 4 m to the sides should be clearly visible in both rear-view mirrors.

- If not, adjust the mirror angles accordingly.



INSPECTION AND MAINTENANCE

Daily inspection

After using the vehicle under adverse conditions, after rain, or after washing the vehicle, you must properly lubricate. To ride safely, you must maintain good lubrication of moving parts, which is necessary to prolong the service life of the vehicle.

Daily inspection and lubrication points include:

- Clutch lever.
- Brake lever.
- Brake pedal bearing.
- Side stand shaft and side stand spring hook.
- Main and passenger footrest shafts and return springs.
- Transmission chain.



CAUTION:

- Except for the transmission chain, which requires chain oil, it is recommended to lubricate other points with coloured lithium grease.



Changing Engine Oil (or with Oil Filter)

1. Start the engine and warm it up for 2–3 minutes, then turn it off.
2. Place a container under the engine to collect the used oil.
3. Remove the engine oil filler cap (1), drain bolt (2), and gasket (3), and drain the oil completely.
4. Remove the outer cover of the oil filter (4).



TIP:

If the oil filter does not need to be replaced, skip steps 4 - 7.

5. Place an oil drain pan under the crankcase.
6. Remove the oil dipstick (5), drain bolt (2), and gasket (3), and drain the oil.
7. Clean or replace the oil filter screen at a service center if necessary.

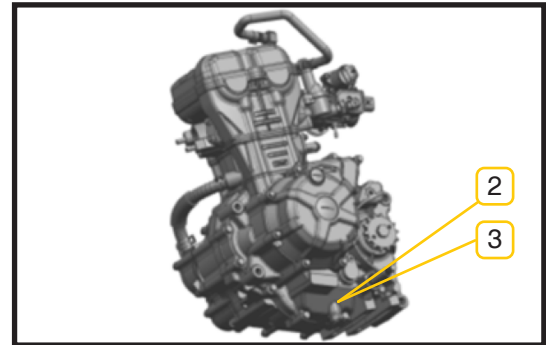
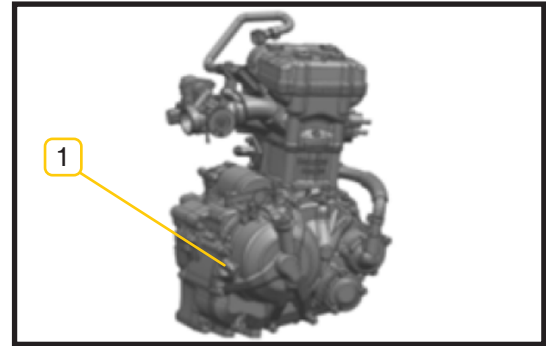



8. Add the appropriate motor oil.

OIL CAPACITY	
Not replacing the oil filter	1 L
Replacing the oil filter	1.1 L
New engine	1.2 L

9. Start the vehicle and let it idle for a few minutes. Check for oil leaks. If any leaks are found, turn off the engine immediately and investigate the cause.

10. Optimum oil level is at top of the rod (6) as a maximum point. The minimum level of oil is position (7).



TIP:

Running the engine with insufficient oil will cause component damage. Excessive oil will affect vehicle speed and may even damage engine parts.

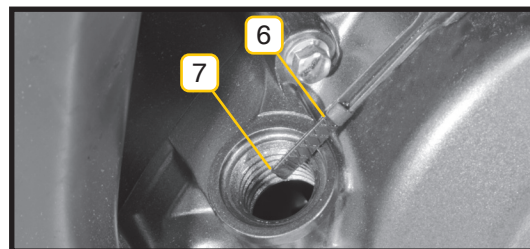
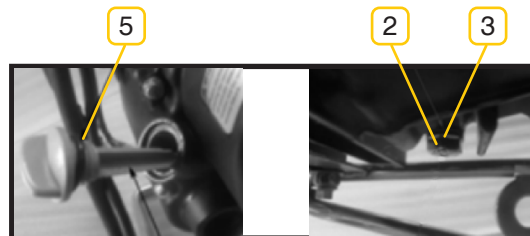
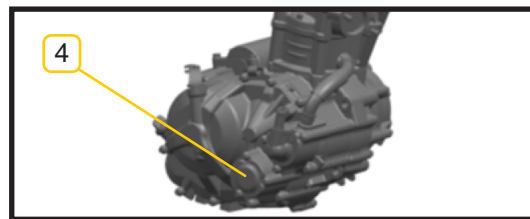



Regular Maintenance

Regular inspection, adjustment, and lubrication will keep your motorcycle operating in the safest and most efficient condition. The time intervals in the regular maintenance schedule are for general reference only. The maintenance interval may be shortened depending on climate, geographical location, terrain, and intended use.

**WARNING:**

If the motorcycle is not properly maintained, or if maintenance is performed incorrectly, the risk of injury during maintenance or operation may increase. If you are unsure how to perform maintenance, please contact your dealer or service center.

**WARNING:**

After riding, the engine, exhaust pipe, brake discs, brake calipers, and brake pads may become very hot. To avoid burns, do not touch any components until they have cooled down.

**WARNING:**

Unless otherwise specified, always turn off the engine before performing motorcycle maintenance. A running engine can cause injury if it comes into contact with your body or clothing. Electrical circuits may cause electric shock or fire. Performing maintenance or repairs while the engine is running can cause eye injury, fire, or carbon monoxide poisoning.



Spark plug

The spark plug is an important component in the engine and is easy to inspect.

Periodically remove and inspect the spark plug because heating and soot deposits slowly deteriorate it. If the electrode is excessively eroded, or if there is too much soot or other deposits, replace the spark plug with another of the recommended type and thermal grade.



TIP: Before assembling any spark plug, measure the separation between electrodes with a feeler gauge and adjust according to specifications.



CAUTION: When installing the spark plug, always clean the surface of the washer housing to prevent debris from entering the combustion chamber. Screw the spark plug in by hand, gently along the threads, and finish by tightening with a suitable wrench.

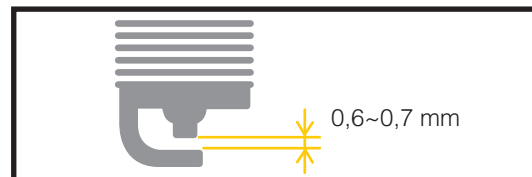

SPARK PLUG TYPE

CR9 E (NGK)

SEPARATION BETWEEN ELECTRODES

0,6~0,7 mm

TORQUE SPECIFICATION

25 Nm



Engine Oil and Oil Filter

Before each ride, check the engine oil level using the dipstick attached to the oil cap.

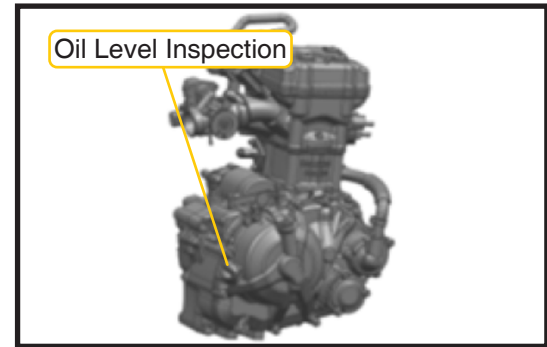

Selection of Engine Oil

Engine oil is critical to engine performance and lifespan. Use only the specified oil; do not use inferior engine oil, gear oil, or vegetable oil as substitutes. Recommended Oil: GRO SMART OIL 10W-40 grade gasoline engine oil. If switching to a different oil, it must meet or exceed SG grade, and viscosity should be selected according to regional and temperature conditions. When changing oil, drain all old oil from the crankcase before adding new oil.



TIP:

Do not discard used engine oil directly. It must be collected and disposed of properly to avoid environmental pollution.



Checking Engine Oil Level

1. Place the motorcycle on level ground, ensuring it stands upright. Tilting the motorcycle will result in an inaccurate oil level reading.
2. Start the engine, warm it up for 2–3 minutes, then turn it off.



TIP:

Allow the engine oil to cool before checking the level to avoid inaccurate readings due to high oil temperature.

3. Wait 5 minutes for the oil to settle , then check the oil level through the dispstick.



TIP:

The oil level must be between the upper and lower marks on the dispstick.

4. If the oil level is at or below the lower mark, add the recommended engine oil until it reaches the upper mark.



Cooling system

The radiator, with great cooling power thanks to forced ventilation with an electro-fan that activates if necessary, is on the right side of the front of the motorcycle, behind the protective grille.



TIP: Check that the radiator is entirely full because this means that you can be sure that the coolant fluid is travelling the entire circuit. To verify the fluid level, lift the radiator's cover, while the vehicle is cold, and replace if necessary.



CAUTION: Never open the radiator's cover when the engine is hot. The boiling liquid can be released under pressure, which is dangerous. Use closed-circuit antifreeze. Using any other fluid may damage the elements in the radiator or the cooling circuit. This type of breakdown is not covered under the vehicle warranty.

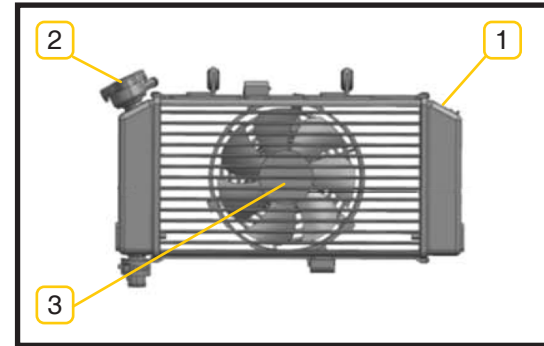

- 1 - Radiator
- 2 - Radiator Cap
- 3 - Cooling Fan

COOLANT TYPE

GRO 30% GREEN



Coolant is composed of coolant concentrate and distilled water, and has antifreeze function. It dissipates heat through circulation to lower the engine temperature. New vehicles are filled with coolant at the factory. During maintenance, pay attention to the coolant level (2). If it is below the lower limit, add it in a timely manner:

1. Open the radiator cap (1), add coolant to the reservoir until it reaches approximately the upper limit.

When the coolant in the radiator becomes cloudy or reaches the maintenance cycle, replace it promptly. If the coolant, radiator, or reservoir has been replaced, add coolant according to the following steps:

1. Place the motorcycle on a flat surface and prop up the side stand.
2. Remove the radiator cap, add coolant until it reaches the filler neck and no more can be added.
3. Refit and tighten the radiator cap.
4. Start the engine and let it idle for 2–3 minutes.
5. Open the radiator cap again and continue adding coolant until full.
6. Repeat this process three times. Refit and tighten the radiator cap.
7. Open the reservoir cap and inject approximately 168 ml of coolant.

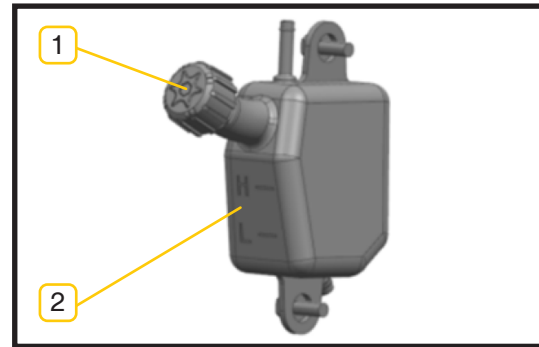



Cooling System Inspection

Check for leaks at the water pump and coolant hose connections, and inspect hoses for damage or aging. Squeeze the hoses to check for cracks and replace them immediately if any are found. If leaks are detected, contact a qualified technician. Do not attempt to disassemble the system yourself. Check the coolant level in the reservoir, ensuring it remains between the upper and lower marks. Add coolant if necessary.

Clutch Adjustment

Grip the clutch lever and operate it. The free play at the end of the lever, before noticeable resistance is felt, should be 10–20 mm.

- 1 - Lock nut
- 2 - Adjusting screw

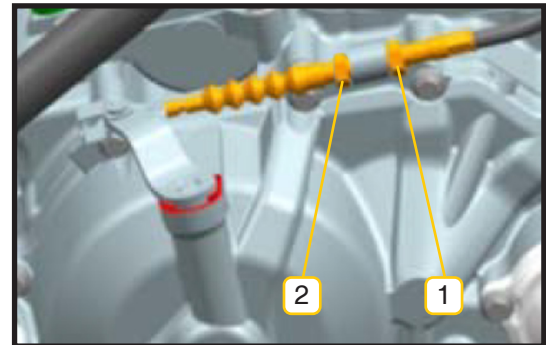



Replacing the Air Filter

The air box (1) should be serviced regularly according to the maintenance schedule. In particularly damp or dusty areas, more frequent inspection and replacement are required.

1. Remove the front seat.
2. Remove the air box cover bolts (2) and open the cover (3).
3. Remove the air filter element bolt (4) and pull out the used filter.
4. Install the new air filter element (5) into the air box, tighten the element bolt, and secure the clip nut (6).
5. Reinstall the air box cover and tighten the cover bolts.



TIP:

Do not run the engine before installing the filter, as unfiltered, dust-laden air will cause excessive wear to the pistons and cylinders.

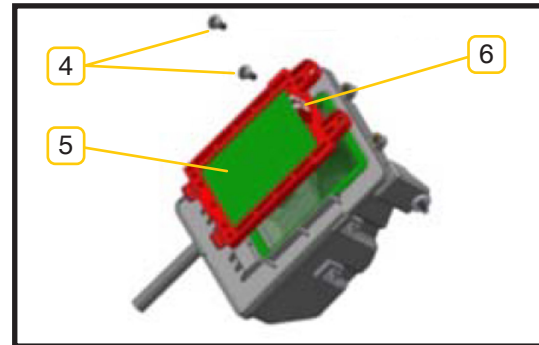
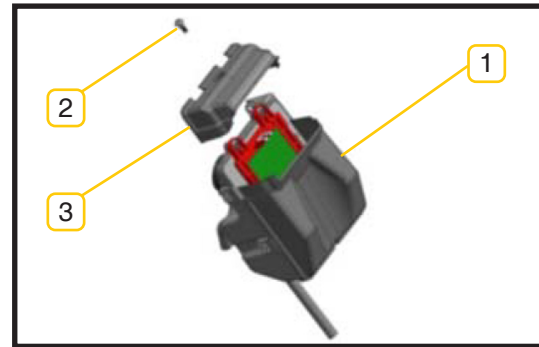



Throttle Cable Adjustment

1. Check that the throttle grip rotates smoothly from the fully open to the fully closed position.
2. Inspect the throttle cable between the grip and the throttle body for damage. If the cable is frayed, stuck, or routed incorrectly, replace it immediately.
3. Verify that the free play (rotation) of the throttle grip is 2–6 mm.

Adjustment Procedure

1. Move the protective cover aside.
2. Loosen locknut (2), then turn adjusting nut (3). If further adjustment is needed, loosen adjusting nut (2) and turn the adjusting screw.
3. Adjust until the throttle grip has 2–6 mm of free play.
4. Tighten the adjusting nut to secure the adjustment.
5. Return the protective cover to its original position.

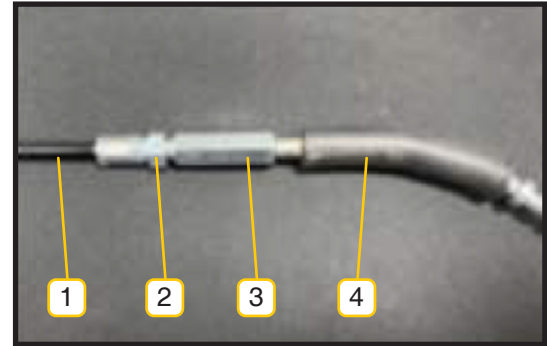

1. Throttle cable (1)
2. Locknut (2)
3. Adjusting nut (3)
4. Protective cover (4)



Brake System Inspection

The brake system will wear over time. When wear reaches a specified limit, the components shall be replaced by an authorized service center.

The minimum allowable thickness of the brake disc is 3 mm. Perform the following brake system checks before each ride:

1. Check the fluid level in the brake fluid reservoir and inspect the entire system for leaks.
2. Inspect brake hoses and the fluid reservoir for leaks or cracks.
3. Check the wear condition of brake discs and brake pads.
4. The free play of the front brake lever should be 10–20 mm, and the free play of the rear brake pedal should be 20–30 mm.

Check the brake fluid level. It should be between the two marked lines on the reservoir. Both excessive and insufficient fluid levels will affect braking performance; the level must be maintained within the specified range.



CAUTION:

- Hydraulic disc brakes operate under high pressure. For safety and reliability, brake hoses, the fluid reservoir, and brake fluid must be replaced no later than the intervals specified in this manual.
- If the brake lever feels spongy or soft when operated, it indicates air is present in the hydraulic brake system. Have the system bled by an authorized service center or dealer before riding. Air in the brake system reduces braking efficiency and can lead to loss of control and accidents.



Rear Brake Adjustment

1. Prop up the motorcycle.
2. Check the free play of the rear brake pedal (1), which is the distance it travels from the resting position until the brakes just start to engage.
3. If adjustment is needed, loosen the locknut (2) and adjust the exposed length of the adjusting bolt to increase or decrease pedal travel.
4. Depress the rear brake pedal (1) several times, then release the brake and check that the rear wheel rotates freely.
5. Once the adjustment is correct, tighten the locknut (2) to secure it.

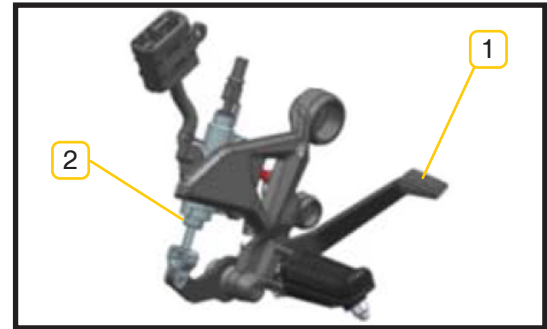

Rear brake pedal (1)

Rear brake pedal position adjusting bolt (2)

Inspecting Front and Rear Brake Pads

Check if the brake pads are worn to the minimum thickness limit.

Inspect the front and rear brake pads regularly according to the maintenance and lubrication schedule. The minimum allowable thickness of each brake pad is 2 mm. If the pads are worn down to the point where they are nearly touching the brake disc, have them replaced by an authorized dealer or service center immediately.

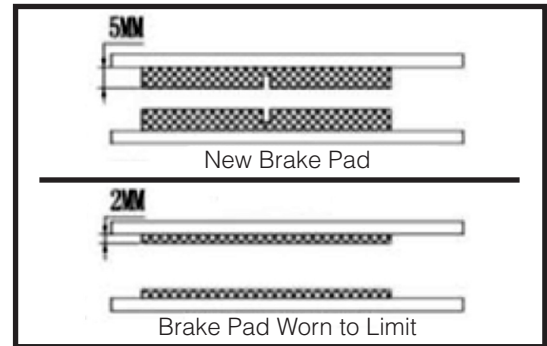



Checking Brake Fluid Level

Front brake

- Maximum level mark (inside)
- Minimum level mark (1)
- Front brake fluid reservoir cap (2)

Rear brake

- Maximum level mark (1)
- Minimum level mark (2)
- Rear brake fluid reservoir cap (3)

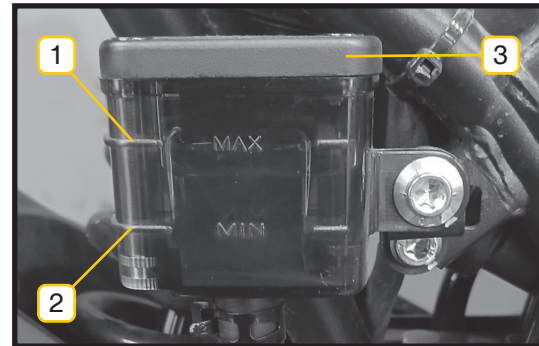
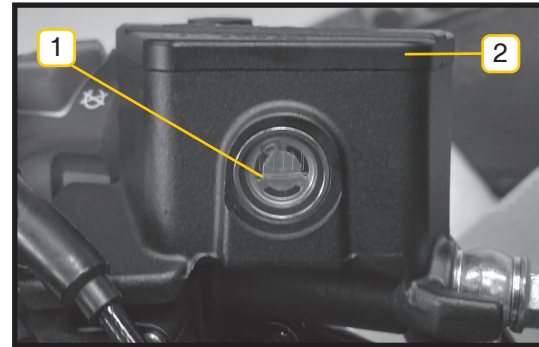

CAUTION:

• The brake fluid in the hydraulic disc brake system must not be contaminated with water or other impurities, as this will cause severe damage to the brake system and reduce braking performance. Brake fluid is highly corrosive. Do not allow it to come into contact with painted surfaces or plastic parts, as it will damage them. Only use DOT 4 brake fluid.



Transmission chain (adjustment and tension)

The chain must be adjusted to have 30 to 40 mm tolerance at the midpoint between the output gear and rear pinion.

To adjust the proper tension, you must conduct these steps on both and equal sides of the wheel:

- 1- Put the gearshift box in neutral and loosen the nut and axle (1) of the rear wheel.
- 2- Loosen the fastening nut (3)
- 3- With the screws (2), adjust the chain's tension, making sure that there is always the same distance on both sides of the axle. To this end, use the ruler marks (4) on the swingarm.
- 4- Secure the position with the 2 nuts (3) and tighten the nut that holds the rear wheel axle.

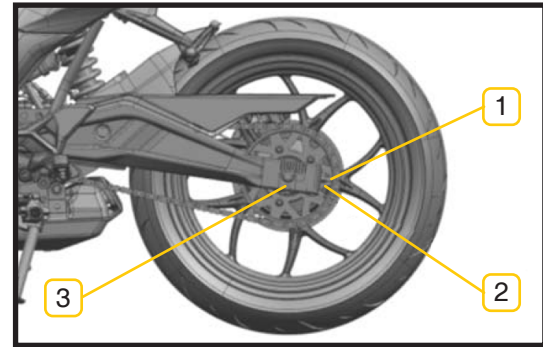

TIP: The chain must be kept perfectly clean and adequately lubricate every week.



Drive Chain Inspection

Before each ride, check the drive chain's length and the contact surfaces of the front and rear sprockets. Inspect the condition of the chain and sprockets regularly as specified in the maintenance manual.



TIP:

If the front or rear sprockets are worn to their service limit, contact your dealer or service center for inspection and replacement.

Shift the transmission to neutral and turn off the engine (ignition switch off).

Use your fingers to move the middle of the chain up and down to check if the tension is correct. Inspect the drive chain for damage, excessive wear, or elongation. Replace the chain if it is damaged, worn, or too long. Inspect the front and rear sprockets for excessive wear, chipped teeth, or broken teeth. Replace the sprockets if necessary.

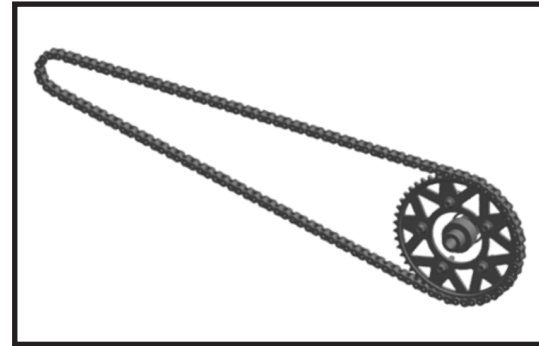



Side Stand Inspection and Lubrication



CAUTION:

- If the side stand does not extend or retract smoothly, have it inspected and repaired by an authorized service center immediately. A malfunctioning stand may contact the ground while riding, distracting the rider and leading to loss of control.

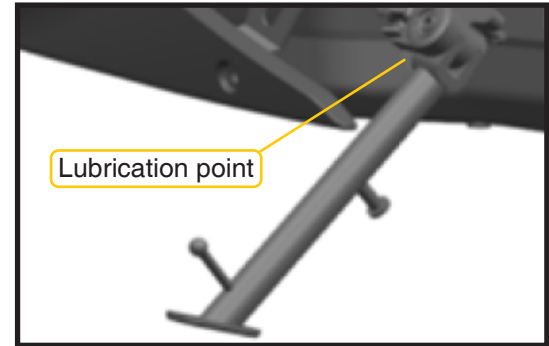



Front Fork Inspection

Inspect the condition of the front forks regularly as specified in the maintenance manual.

Check the fork tubes for scratches, wear, or oil leaks.

1. Place the motorcycle on level ground and ensure it is upright.
2. Apply the front brake, then push down on the handlebars several times. Check that the forks compress and rebound smoothly.



TIP: If any damage is found or the forks do not operate smoothly, contact your dealer or service center for inspection or replacement.



Front Fork Inspection

Inspect the steering head regularly as specified in this manual. Worn or loose steering head bearings can lead to dangerous riding conditions.

1. Grasp the lower part of the front forks and try to move them forward and backward. If any play is felt, contact your dealer or service center for inspection and maintenance.

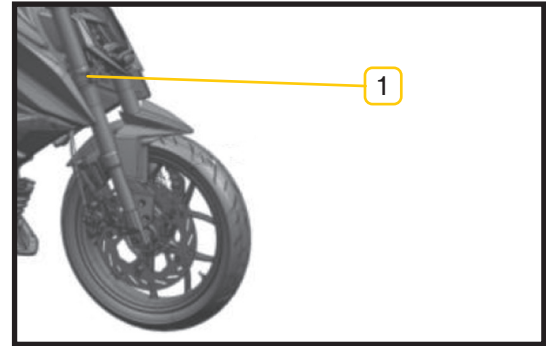

Front and Rear Wheel Bearing Inspection

Inspect the wheel bearings regularly as specified in the maintenance manual. If there is lateral play in the wheel or the wheel does not rotate smoothly, contact your dealer or service center for inspection and maintenance.



Battery Inspection

The battery is located under the rider's seat. This motorcycle is equipped with a maintenance-free lead-acid battery, so there is no need to check the electrolyte level or add distilled water. However, you should inspect the battery cable connections and, if necessary, check that the battery mounting screws are securely tightened.



CAUTION:

- Batteries produce explosive gases. Keep away from sparks, flames, cigarettes, and other ignition sources. Ensure adequate ventilation when charging in an enclosed space.
- Store the battery in a location out of reach of children.

Checking Battery Charge

If you suspect the battery is low, check the voltage across its terminals. If it is below 12.3V, charge it immediately. Note that additional electrical accessories will accelerate battery discharge.

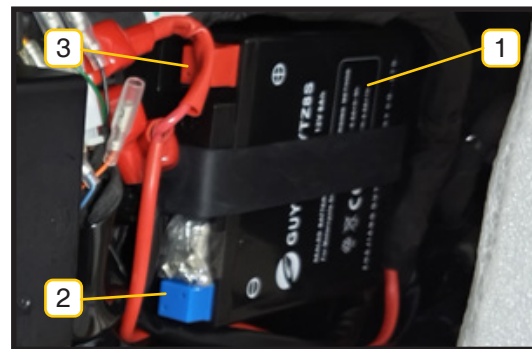

1. Battery
2. Negative terminal cable (Black)
3. Positive terminal cable (Red)



Battery Storage

1. If the motorcycle will not be used for more than 1 month, remove the battery and store it in a cool, dry place.



TIP: Always turn off the vehicle power before removing the battery. Disconnect the cables in this order: negative terminal first, then positive terminal.

2. If storing for more than 2 months, inspect the battery at least once per month and recharge it if necessary.



TIP: When installing the battery, connect the positive terminal first, then the negative terminal.

3. After installation, confirm that the battery cables are connected correctly.



Fuse Replacement

The cable fuse box , which contains fuses for other circuits, is located under the vehicle seat. If a fuse blows, replace it as follows:

1. Turn off the vehicle power and open the seat.
2. Remove the blown fuse and install a new one with the specified amperage rating.



CAUTION:

- Never install a fuse with a higher amperage rating than specified , as this may damage the electrical system and cause a fire.



Troubleshooting Table / Starting Problems & Engine Performance Issues

Gasoline

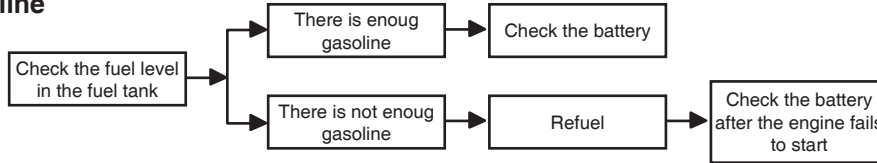

Battery

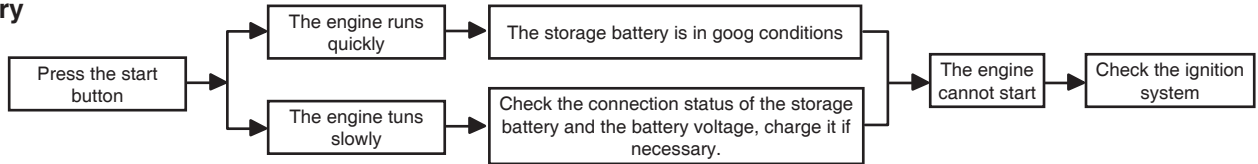

Ignition system

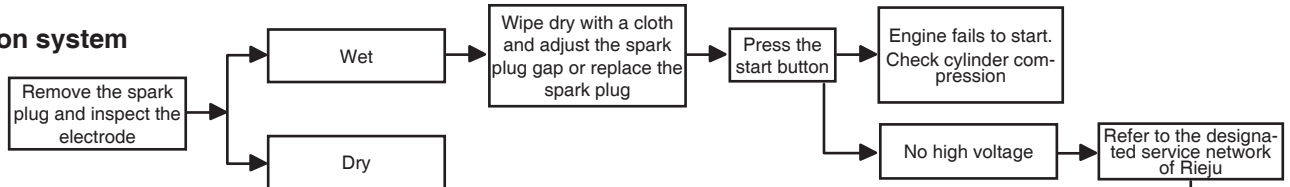

Cylinder Compression

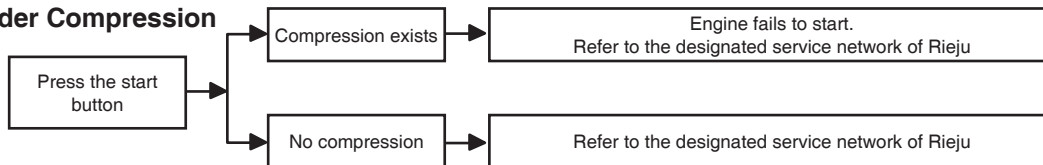



Maintenance Schedule

You must service and maintain the motorcycle as shown in the table below.

Component	Maintenance interval				
	500KM	3.500KM	6.500KM	9.500KM	+3.000KM
Air filter	L	C	C	C	C
Engine oil	C	C	C	C	C
Oil filter	C	C	C	C	C
Check operation of the oil pump	I	I	I	I	I
Check transmission for leaks	I	I	I	I	I
Check crankcase for leaks	I	I	I	I	I
Valve adjustment				I	I (+9000 km)
Clutch			I	I	I
Spark plug	I	I	I	C	I/C (+10000 km)
Drive chain tension and wear	I/E	I/E	I/E	C	I/E-C (+10000 km)
Battery	I	I	I	I	I-C (if necessary)
Electrical system	I	I	I	I	I
Fuel lines	I	I	I	I	I
Exhaust system	I	I	I	I	I
Operation of controls, throttle and cables	I	I	I	I	I



Steering and handlebar					
Shock absorber					
Front/rear suspension					
Side stand		I/E	I/E	I/E	I/E
Brake mechanism / lining					
Brake fluid					I-C (every 2 years)
Brake pads					I-C (according to wear)
Brake disc					
Coolant and level					I-C (every 2 years)
Lights					
Tyres: pressure and condition					
Engine bolts and nuts					
Bolts and nuts of each componen					



When riding in extremely humid or dusty areas, the maintenance interval should be shortened appropriately.

I check-adjust

C: change

E: grease

L: clean



Engine Overheating



CAUTION:

- Do not remove the radiator cap when the engine is hot. Scalding coolant and steam may be released under pressure, causing severe burns. Always wait until the engine has cooled completely before performing any maintenance.
- To safely remove the radiator cap: Place a thick cloth, such as a towel, over the cap. Slowly turn it counter-clockwise until it reaches the detent to release any residual pressure. Once pressure has been fully released, press down on the cap and continue turning it counter-clockwise to remove it.

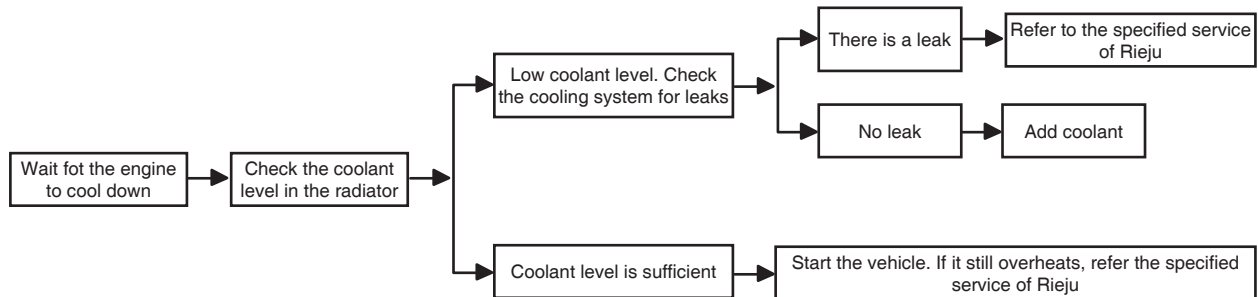



VEHICLE STORAGE AND CLEANING

Vehicle storage

If your motorcycle will not be used for an extended period, special maintenance is required and certain materials, tools, and technical expertise are necessary. We therefore recommend that these operations be performed at an authorised **RIEJU** dealer.

If you wish to carry out these procedures yourself, please follow the methods described as follows:

- Completely replace the oil with new oil.
- Block the air filter intake and the exhaust outlet with a cloth soaked in clean oil to prevent humid air from entering the engine.
- Completely drain all the fuel from the fuel tank.
- Remove the battery, clean its surface with neutral soapy water, and remove any rust from the positive and negative terminals.
- Store the battery in a room at a temperature above 0 °C.



- ☒ Adjust the tyre pressure to the specified value.
- ☒ Thoroughly wash the vehicle.
- ☒ Spray a rubber protectant on the surface of all rubber parts.
- ☒ Coat the entire vehicle with automotive protective wax.
- ☒ Finally, cover the vehicle with a cloth and store it in a dry, well-ventilated area.



CAUTION:

- Recharge the battery you have removed once per month.



How to reactivate the vehicle

- ☒ Thoroughly clean the vehicle.
- ☒ Remove the cloths from the air filter intake and the exhaust outlet.
- ☒ Completely replace the engine oil and oil filter.
- ☒ Install the battery.
- ☒ Start the vehicle.



Vehicle protection

Depending on how you use it, wash the vehicle frequently and keep it clean and dry.

Remove any dirt or residues such as bird droppings, asphalt, or salt from the surface as soon as possible.

Attempt to use a vehicle cover. Prolonged exposure to sunlight may cause ageing and discolouration of exterior parts.

Cleaning the vehicle

Wash the vehicle with cold water.

Clean thoroughly with a soft cloth and neutral detergent.

Do not spray water directly onto the vehicle.

Do not wash the vehicle with high-pressure water.



On rainy days or after washing the motorcycle, a small amount of moisture may appear as fog inside the headlamp or indicator. Simply turn on the lights for a while and the moisture will disappear. This is normal since the lamps are designed with ventilation holes.



CAUTION:

The braking performance of wet brakes is reduced. Test the braking system repeatedly at low speed after washing to dry it quickly.



CAUTION: Do not apply de-greaser to the wheel axles or the chain.



CAUTION: RIEJU accepts no responsibility for the use of corrosive degreasers that may stain or damage motorcycle parts. **RIEJU** is not liable for any damage or defects caused by using high-pressure water to clean the motorcycle.



MODIFICATIONS AND ACCESSORIES

Only use original **RIEJU** parts and accessories.

You can obtain genuine parts, accessories, and other **RIEJU** products through authorised dealers. At the same time, professionals will advise you on installation and use.

The safety, performance, and compatibility of these parts and products have been tested and are guaranteed. On the other hand, no responsibility will be accepted for unauthorised parts or accessories.

Whenever you plan to replace parts, ensure compliance with all laws and regulations so that your vehicle meets national road vehicle requirements and other legal and technical specifications.



CAUTION:

- The unauthorised modification of components, such as the electronic control system, may cause vehicle damage and accidents.



WARRANTY

Standards regulating manufacturer **RIEJU'S** warranty.

The company **RIEJU** hereby guarantees the end consumer, purchaser of a vehicle manufactured by **RIEJU**, that both the materials and the manufacturing are free from defect, pursuant to the highest quality standards. Consequently, **RIEJU** hereby provides the end purchaser (hereinafter, the “purchaser”), pursuant to the conditions set forth below, with a warranty to repair all material or manufacturing defects found on a new motorcycle at no cost, within the established warranty period and with no limitation in terms of the number of kilometres travelled or the number of hours the vehicle has been operated.

Warranty Period

The warranty period shall be governed by warranty law in the vehicle's country of sale, in force at the time it is sold.



Warranty claims for defects not brought to the attention of a **RIEJU**-authorised dealer before the end of the warranty period shall be excluded.

Purchaser obligations

RIEJU may legitimately reject warranty claims if, and to the extent that:

- a) The purchaser has not brought the vehicle to any of the inspections and/or to undergo maintenance tasks as required in the user manual, or the date set for these inspections or maintenance tasks has passed. Also excluded from the warranty are defects that appear before the date established for an inspection or



maintenance task that never occurred, or that will occur after the established date.

b) Inspections, maintenance work, or repairs have been conducted by third parties not recognised or authorised by **RIEJU**.

c) Any maintenance or repair has been conducted in violation of the technical requirements, specifications, and instructions set forth by the manufacturer.

d) Replacement parts not authorised for use by **RIEJU** have been used in maintenance or repair work on the vehicle, or if, and to the extent that, fuels, lubricants, or other liquids (including, but not limited to, cleaning products) that were not expressly mentioned in the User Manual's instructions have been used on or in the vehicle.

e) The vehicle has been, in any way, altered or modified or fitted with components other than the components expressly authorised by **RIEJU** as components allowed for the vehicle.

f) The vehicle has been stored or transported in a way that is contrary to technical requirements.

g) The vehicle has been used for a special use other than ordinary use, such as competition, racing, or in an attempt to beat a record.

h) The vehicle has suffered a fall or accident that directly or indirectly causes damages.

Warranty exclusions

The following articles are excluded from the warranty:

a) Replacements for wear, including, but not limited to, spark plugs, batteries, fuel filters, oil filter elements, chains (secondary), engine output pinions, rear rings, air filters, brake discs, brake pads, clutch disks, bulbs, fuses, carbon brushes, footrest rubber, tyres, chambers, wires, and other rubber components, ex-



haust pipe, and washers.

- b) Lubricants (for example, oil, grease, etc.) and operational fluids (for example, battery fluid, coolant, etc.).
- c) Inspection, adjustment, and other maintenance work, as well as all kinds of cleaning work.
- d) Damage to the paint and consequent rust due to external influences, such as rocks, salt, industrial fumes, and other environmental impacts, or inadequate cleaning with inadequate products.
- e) Damages caused by defects, as well as expenses caused directly or indirectly by the defects (for example, communications expenses, lodging expenses, car hire expenses, public transport expenses, recovery vehicle expenses, emergency messenger expenses, etc.) as well as other financial harm (for example, caused by loss of use of a vehicle, lost income, lost time, etc.).
- f) Acoustic or aesthetic circumstances that do not significantly affect conditions for use of the motorcycle (for example, small or hidden imperfections, normal noise or vibration in use, etc.).
- g) Circumstances due to vehicle ageing (for example, fading of painted surfaces or metal coating).

Miscellaneous

- a) If repair of the defect or replacing the part is disproportionate, **RIEJU** shall be entitled to decide, at its sole discretion, whether to repair or replace the defective parts. Ownership over the replaced parts, if applicable, shall be held by **RIEJU**, with no other consideration. The dealer authorised by **RIEJU** whom has been entrusted to repair defects shall not be authorised to make binding statements on **RIEJU'S** behalf.
- b) If there is doubt as to whether there is a defect or a visual or material inspection is required, **RIEJU** reserves the right to require that the parts being claimed under the warranty be sent to it, or to request that a **RIEJU**



expert examine them. Any additional warranty obligations for replaced parts at no cost or for any services provided at no cost under this warranty shall be excluded. The warranty for replaced components during the warranty period shall end on the expiry date of the warranty period of the respective product.

c) If a defect cannot be repaired and its replacement is disproportionate for the manufacturer, the consumer under warranty shall be entitled to cancellation of the contract (payment of a compensation) or partial reimbursement of the purchase price (discount) instead of motorcycle repair.

d) The purchaser's warranty claims under the purchase-sale contract with the authorised dealer shall not be affected by this warranty. This warranty shall not affect the purchaser's additional contractual rights under the general business conditions of the authorised dealer. However, said additional rights may only be claimed with the authorised dealer.

e) If the purchaser resells the product during the warranty period, the terms and conditions of this warranty shall continue to exist under their current scope, such that rights to claim pursuant to this warranty under the terms and conditions governed by this document shall be transferred to the new owner of the motorcycle.



RIEJU

FOR EVERYDAY ADVENTURE